



# AUTOMATION FOR CHECKING WATER QUALITY USING ZIGBEE AND GSM

<sup>1</sup>Shrushti Sethi, <sup>2</sup>Sachin jadhav

<sup>1,2</sup>Department of E&TC M.S.S college of Engineering(Jalna )

Email: [shrushtisethi90@gmail.com](mailto:shrushtisethi90@gmail.com), [sachin.jadhav.pes@gmail.com](mailto:sachin.jadhav.pes@gmail.com)

**Abstract:** The conventional technique of measuring the quality of water is to gather the samples manually and send it laboratory for analysis, but this technique is time overwhelming and not economical. Since, feasibility does not exist to test the water sample in laboratory for each and every hour for measurement of its quality. The water quality measuring system can measure the essential qualities of water in real time. The system consists of multiple sensors to measure the standard of water, microcontroller, zigbee transceiver to send the information to the watching centre and GSM is used when values are mismatched to send alert message. It's a true time system which is able to endlessly measure the standard of water and can send the measured values to the watching centre when each predefined time. The system relies on microcontroller 328P, zigbee module and GSM.

**Keywords:** GSM Module, Microcontroller, Multiple sensors, zigbee module.

## I. INTRODUCTION

Water quality may be an important term to explore. Since the standard technique of water quality measuring isn't economical, as its not feasible to take the water sample to the laboratory after every hour for measuring it's quality thus there was a necessity to develop a system which is able to measure the standard of water in real time for lakes and also the system must be economical, correct and low price. The standard of water depends on many things. We've used many studied parameters in conjunction with one another to work out the

water's quality. These include: pH, turbidity, conductivity sensor for checking water quality at different depth in lakes and in various water resources. These measured units then with the help of wireless unit is send to the receiver, then if the values are mismatched then with the help of GSM module the message is send to the authority.

The objective of the work is to develop a low cost reliable water quality sensing system which helps us to know the different parameters at different depth. Parameters and characterization of this sensing system have given positive results along with the operating theory and justification of design and usage.

The water quality measuring system for lakes or any other water resources makes use of multiple sensors, information acquisition module and data transmission module. Information acquisition module includes microcontroller 328P. Data transmission module includes GSM and zigbee module. There are numerous sensors that measures turbidity, pH, and conductivity sensor used for measuring water quality at different depths. This technique conjointly uses ADC. The measured values are then transmitted to the watching centre via zigbee and then displayed on LCD screen by the microcontroller and send the data through GSM when crosses the threshold limit. The system has the advantage of potency, accuracy and low price.

## II. RELATED WORK

There are many works on the application of WSN for monitoring system such as in [2], where Zigbee is used to monitor the condition of long span bridge after considering disadvantages

of the currently used wire and cable for data communications such as high installation cost of communication and power supply for the sensors, difficulty in the installation of steel pipeline for protecting the cables, sensor data distortions due to temperature changes on cables, noise affecting cables and sensors etc. The Zigbee is used for the short distance communication whereas CDMA (Code Division Multiple Access) infrastructure was used for long distance communication between sensors and the server system. Another application of Zigbee in monitoring system is found in [3] for parking management system. In this work the Zigbee module is based on the ATmega128L microprocessor combined with the Chipcon CC2420 transceiver IC. In [4], an electrocardiogram (ECG) signal monitoring system based on Zigbee is presented. This system is proposed to be used in telemedicine service where there are no direct contact between the patient and the physician and becomes a fundamental for the development of efficient remote monitoring systems, providing continuous, real-time and accurate information about health conditions of the patient. Coverage performance measurement result in the indoor environment shows the system able to cover two or three rooms depending on the wall thickness and the relative position of transmitter and receiver as shown. From all the previous related works described, it can be concluded that there are limitless possibilities of Zigbee in wireless sensor network application. Solution providers of Zigbee offer various kind of platform in the market based on user requirement. For this paper, the difference is the use of high transmission power with low power consumption Zigbee platform.

### III. SYSTEM HARDWARE DESIGN

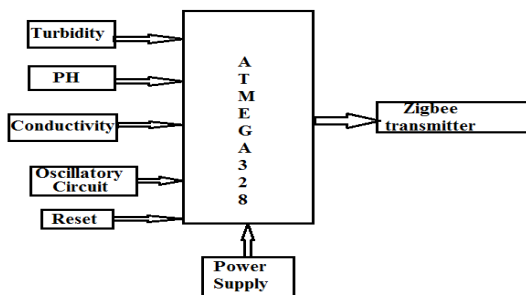

**Fig.1. Transmitter**

The block diagram of the system consists of two sections: transmitter and receiver section which effectively measures water quality by using

different sensors like pH, turbidity, conductivity sensor, and the system also consist of microcontroller 328P, GSM module, LCD, and zigbee module.

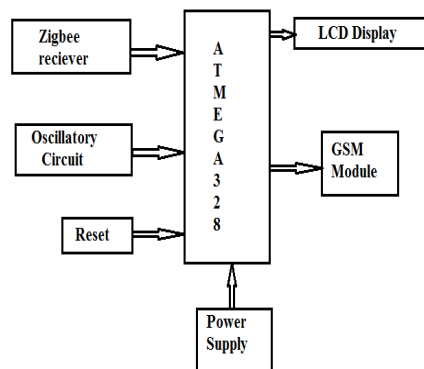

**Fig.2. Receiver**

#### 2.1 Sensors

As shown in the transmitter block there are three sensors used in the system, which are mainly as follows:

- Turbidity
- Ph
- Conductivity
- TDS.

The term turbidity is used to describe the reduction in water clarity or "cloudiness" as perceived by the human eye caused by the scattering of light due to particulate matter suspended in solution. Greater the turbidity gives the more cloudiness in the water. As the turbidity increases it reduces the transmission of light. Turbidity sensor makes use of LDR and LED.

A PH electrode measures hydrogen ion content in solution and generates an electrical potential. The main concept behind the PH electrode is basically on the principle that an electric potential is been generated, when two liquid samples of different PH come in contact at different side of a thin glass membrane. PH may be a measure of the acidity or basicity of associate solution.

Conductivity is a measured by the number of ion concentration in a liquid sample. It is also used to measure the amount of nutrients, quality, salts and impurities in water or aqueous sample. Conductivity is measured with the help of two conducting plates. To improve accuracy, it is directly placed in the measurement area.

Total dissolved solid (TDS) determines the quantity of minerals and salts reside within the water. Total dissolved solid in water will be determined by multiplying the conductivity by a factor and typically this factor is taken as 0.67.

$$\text{TDS} = 0.67 \times \text{conductivity}$$

We will not use separate device for determining total dissolved solid in water, we are going to measure conductivity and multiply it by zero.67. This all are going to be done by programming.

## 2.2 Microcontroller used

The ATmega328P is a low-power CMOS circuit with 8-bit microcontroller, and is depended on the AVR with enhanced RISC architecture. By executing high power instructions in a single clock frequency, the ATmega328P gets a result of throughputs approaching 1 MIPS per MHz which allows the system designer to find optimize power consumption versus processing speed.

## 2.3 Data Transmission

### GSM Module

The SIM900 can be used embedded in many of the applications as it is complete Quad-band GSM/GPRS solution in a SMT module. Feature for an industry-standard interface, the SIM900 has the capability of delivering GSM/GPRS 850/900/1800/1900MHz performance for voice, Data, SMS, and small form factor Fax and requires low power consumption. GSM900 has an small configuration of 24mm x 24mm x 3 mm, and can be fit in nearly all the space requirement in M2M application, as there is slim and compact demand of design.

SIM900 is designed with a highly powerful with single-chip processor and integrated AMR926EJ-S core, Quad - band GSM/GPRS module having a size of 24mmx24mmx3mm, SMT type suit for many application, An embedded of highly Powerful TCP/IP protocol stack, depends on mature and field-proven platform, and is backed up by a support service provided, from definition to production and design.



Fig.3. GSM 900

### Zigbee module.

Zigbee 802.15.4 RF modules are of XBee family, looking for excellent wireless performance, it is the premiere choice for OEMs and a small form factor solution and also cost-effective. Every XBee module comes in a two range that can be regular or long-range. Pin-for-pin compatibility is found in all XBee modules with the exception of a few varying I/O features, a standard footprint for OEMs is provided to different applications.

XBee Series 1 is depended on Zigbee 802.15.4 silicon from free scale. It is ideal for the topologies such as point-to-multipoint, point-to-point and peer-to-peer because of 802.15.4 firmware feature. The XBee Series 1 gives the user maximum control over minimum latency and network nodes. XBee Series 2 is referred from Zigbee/802.15.4 silicon which is from Ember. For creating ad-hoc mesh networks is based from features of Zigbee firmware. Automatic route discoveries are performed by the XBee Series 2 which can create a self-healing network for the routers which are fully function and also for low-power end devices. Whereas XBee Series 1 and Series 2 modules do not communicate with each other. It is basically known for ease of use, the XBee modules are ready in form and can be operated out of the box and an API for advanced, user-settable configurations, it also offer simple AT commands.



Fig.4. Zigbee module

For effective wireless data communication without a license, 2.4 GHz ISM band, XBee modules are known worldwide. XBee modules are basically a part of Dig's full line of Drop-in Networking products. With the connection of Port X gateways and XBee device adapters, extenders and modules, this provides end-to-end wireless connection to commercial-grade electronic devices which is in locations where proper infrastructure exists or where customer needs are satisfied.

#### IV. PROGRAMABLE LOGIC

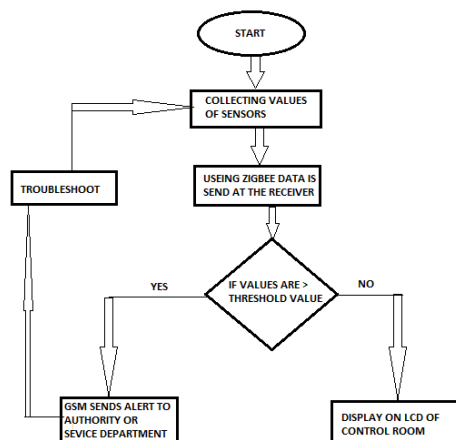

The water quality measuring system uses pH, turbidity, conductivity Sensor to measure the standard of water. Device then measures the corresponding values of the water. Since the outputs of the sensors measured are analog in nature and microcontroller will handle solely digital signals, the system makes use of ADC which is inbuilt in microcontroller. The outputs of sensors are directly given to ADC, which converts the analog signals into the corresponding digital signals. These digital signals at microcontroller 328P then uses Zigbee module for communication that is to send data at the receiver and GSM module at the receiver side interfaced with microcontroller 328P for communication at a particular level.. Microcontroller sends the measured values to the watching centre by wireless communication zigbee module and further uses GSM module to send message at higher authority when it crosses threshold value. Since it's a real time system thus microcontroller sends the measured values of different parameters to the watching centre after the particular time as per the program. With the information to the watching centre the microcontroller also displays the values of the measured quantities on the LCD. The power

supply unit supplies the appropriate voltage to all the components.

#### V. ADVANTAGES

1. Reliable cost for water quality sensing.
2. Safety and security for different applications.
3. Useful for monitoring rapidly varying values of sensor.

#### VI. CONCLUSION

Real time system for water quality measuring based on GSM and zigbee module is associate economical system that uses numerous water detection device and zigbee GSM network. The system is incredibly versatile and economical. It's real time system that measures numerous parameters present within the water with the assistance of device and send them to the watching centre mechanically. It doesn't need individuals on duty. Its versatile system as a result of simply by replacement the sensors and by creating some changes within the computer code the system will be created to measure completely different parameters of water. The system is reliable and easy and it will be extended to measure water pollution so on. It's a widespread application.

#### REFERENCES

- [1] (2009) The Zigbee Alliance website. [Online]. Available: [http:// www.zigbee.org/](http://www.zigbee.org/)
- [2] Chae, M.J., Yoo, H.S., Kim, J.R., and Cho, M.Y., "Bridge Condit ion Monitoring System Using Wireless Network (CDMA and Zigbee)," *23rd International Symposium on Automation and Robotics in Construction ISARC 2006*, Tokyo, Japan, 3 – 5 Oct 2006.
- [3] Sangmi Shim, Seungwoo Park and Seunghong Hong, "Parking Management System Using Zigbee," *IJCSNS International Journal of Computer Science and Network Security*, Vol. 6 No. 9B, September 2006.
- [4] F. Vergari, V. Auteri, C. Corsi and C. Lambert i, (2009, October 31), "A Zigbee-based ECG Transmission For Low Cost Solut ion In Home Care Services Delivery," *Mediterranean Journal of Pacing and Electrophysiology – Special Issue Article Preview*, [Online], Available : ht tp://www.mespe.net/en/newselem/