



SMART ENERGY METER FOR OPTIMIZATION OF ENERGY CONSUMPTION

Pritam M.Gholap¹, Ishwari S.Kale², Shubham M.Chaskar³
Electronics and telecommunication Department,
MIT College of Engineering, Pune, Maharashtra

Abstract

In rising digital world, use of electromechanical electricity meter is less efficient and inaccurate. This paper helps to overcome many of the flaws present in conventional meters. Wireless meter reading using ZigBee or Bluetooth module and storing using microcontroller is done which reduces tedious job of taking individual meter reading and increased paper work. Also, customers can get information about the power consumption from anywhere or utility providers can cut-off connection in case of billing fraud just by sending an SMS. For this, GSM module is used. Use of LED and keypad enhances user interface and also makes it easy to use. Use of microcontroller for processing the consumption of units increases accuracy and consumes less power than electromechanical device.

Keywords: Smart Energy Meter(SEM), CMRI(Common Meter Reading Instrument), Maximum Demand(MD), Global System for Mobile(GSM), Short Messaging System(SMS).

I. INTRODUCTION

Many countries still use electromechanical meters for measuring electricity consumption. These consist of rotating disk which rotates proportional to load flow and shows respective reading. Now, as there is no system or module for communication, meter readers visit every house and note down the readings. This work is tedious and time consuming. And the readings of meter may be inaccurate due to complete analog processing. One of the major drawbacks is it cannot detect consumption of electricity

under certain value for example use of mobile charger. This leads to inaccurate readings.

To overcome most of these flaws smart energy meters can be used. These consist of microcontrollers which are used to process incoming data, store it and to forward it to communication module. Wireless modules like ZigBee, Bluetooth or RF modules can be used in order to get metering data wirelessly. But as its range is restricted to certain radius we can use GSM module to communicate with meter from remote places. Human error while taking reading will be nullified using wireless technique. Also customers can manipulate usage of electricity as they can get information about consumed units by sending a SMS.

As load calculation is done using controller, data can be stored at customer's as well as utility provider's end. Hence it reduces paper work and its storage. There are less chances of losing or misplacing billing documents as they will get stored directly to respective customer's database. Increased accuracy and efficiency of energy meter and less human errors as less human intervention are some advantages of our proposed system.

II. RELATED WORK

Some meters calculate the current consumption unit through IR sensor unit. The IR transmitter is placed in the rotating unit of the EB meter. The receiver photo diode is placed in a certain place which is used to find no of rotation. By getting the number of rotation we get the current consumption. The following paper had proposed this idea of energy calculation-

E.Moni Silviya, K.Meena Vinodhini, Salai Thillai Thilagam J. "GSM Based Automatic

Energy Meter Reading System with Instant Billing”. (IR sensors and GSM based smart metering is done)[5].

In other centrally managed energy based systems Power line communication (PLC) is established between meters and the grid. Such communication can be costly to establish as cost of wiring is high. Repair works and maintenance also should be done. This problem makes us look towards different alternatives like wireless communication.

“Smart meter based energy management system” by Dr. Péter Kádár proposed use of different communication tools like[7]:

- The Zigbee network is one of the most widely used communication tools. The ZigBee Smart Energy supports the energy meterings, as the Home Display, remote programming of thermostats, lighting and load management.
- The Home Area Network (HAN) operates in wireless and on-the-wire mode, too (e.g. Power Line Carrier, or IEEE 802.15.4 wireless protocol). The main device communicates with all the meters in the building and the gateway keeps contact with the Neighborhood Area Network (NAN).

III. PROPOSED IDEA

Since our meter is electronic in nature, it accepts voltage inputs representing local voltage and current in an electrical power system and converts them to digital using over sampling A/D converters. An on-chip digital processor continuously computes the product of the two signals, which is proportional to instantaneous power. To simultaneously sample inputs we use synchronizing A/D converters which will sample the values that are provided by the two transformers. This provides more accuracy. The transformers provide the values of the energy consumed by the applied load. The energy metering IC will sample the inputs separately and will calculate the peak values, the RMS values, the delay factor and many other useful factors. These values are then translated in the form of energy consumed in Watt-hour format and further to Units of Energy consumed. The respective bill will also be calculated by the controller and displayed on the meter as well as sent to the user and the MSEB office accurately. The basic principle behind the working of this idea is the terms Active Power, Reactive Power and the Apparent Power.

The loads applied to the Energy Meter are of two main types:

- Resistive Loads: Incandescent light bulbs
Any heating device without a fan such as toaster, baseboard electric heater, kettle, etc.
- Inductive Loads: Refrigerators, Freezers
Air conditioners (all types) Fluorescent lights including CF lights, TV, computer, stereo, any wall-wart, Microwave Oven
Washer, Dryer, Vacuum cleaner, Fans etc.

These loads have respective form factors. The power calculation of respective loads will be done as follows:

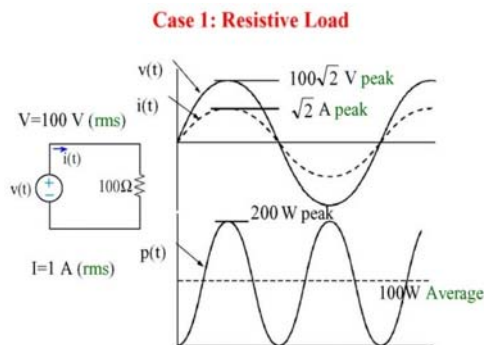

fig1. Resistive Load

Figure 1 represents the voltage and current characteristics of the system in case of Resistive Load.

$V_{\text{rms}} = 100 \text{ V}$ $I_{\text{rms}} = 1 \text{ A}$ Apparent power = $V_{\text{rms}} I_{\text{rms}} = 100 \text{ VA}$. From $p(t)$ curve, check that power flows from the supply into the load for the entire duration of the cycle. Also, the average power delivered to the load is 100 W. **No Reactive power.**

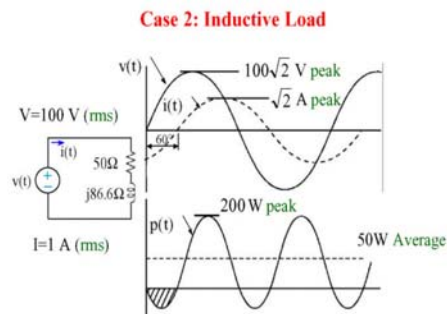

fig.2 Inductive Load

Figure 2 represents the voltage and current characteristics of the system in case of Inductive Load. We can see that there is a lag

between the current and voltage characteristics in case of inductive load.

$$V_{\text{rms}} = 100 \text{ V} \quad I_{\text{rms}} = 1 \text{ A} \quad \text{Apparent power} = V_{\text{rms}} I_{\text{rms}} = 100 \text{ VA}$$

From $p(t)$ curve, power flows from the supply into the load for only a part of the cycle! For a portion of the cycle, power actually flows back to the source from the load. Also, the average power delivered to the load is 50 W! So, the useful power is less in Case 1. There is reactive power in the circuit.

When a circuit has resistive and reactive parts, the resultant power has 2 parts: The first is *dissipated* in the resistive element. This is the **active power, P** . The second is *stored and returned* by the reactive element. This is the **reactive power, Q** , which has units of **volt amperes reactive or VAR**.

While reactive power is not dissipated it does have an effect on the system. Effect for example, it increases the current that must be supplied and increases losses with cables.

In AC circuits, the product of multiplying the current by the voltage is called “apparent power”, because it appears that this is the energy consumed when in reality it may be less. The electrical unit for “Apparent Power” is VA (Volt Amps) and not Watt. This is simply a multiplication of the “V x A”. Since the power company only charges for power consumed (True Power), **“apparent power” is not practical for determining energy consumption.**

Thus, the Active, Reactive and the Apparent Powers are calculated using the following calculations:

Active Power $P = VI \cos \phi$ watts
Reactive Power $Q = VI \sin \phi$ var
Apparent Power $S = VI$ VA

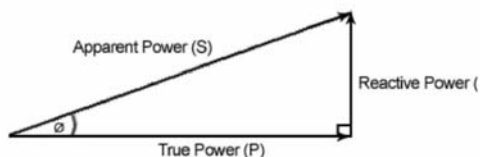

fig 3. Relation between Powers

The figure depicts the relation between active power, reactive power and the apparent power. From the above principle, it is clear that the power which should actually be taken into

consideration for further Units calculations is the Apparent Power. This power is calculated by the proposed system and the total energy consumption of the load is calculated respectively.

An automatic remote meter-reading system based on GSM and Radio Frequency (RF) based communication is also included. It is possible to obtain meter reading when desired so meter readers don't need to visit each customer for the consumed energy data collection and to distribute the bill slips. Microcontroller can be used to monitor and record the meter readings. In case of a customer defaulter, no need to send a person of utility to cut-off the customer connection. Utility can cut off and reconnect the customer connection by short message service (SMS). Furthermore, the customer can check the status of electricity (load) from anywhere. In this system energy meter readings are being transferred by making use of GSM.

IV. IMPLEMENTATION

A. Smart Energy Meter(SEM)

Unlike conventional meters smart meters consist of microcontrollers and hence they are categorized in digital systems. SEM uses sensors to sense voltage and current rather than transformers. Then these sensed signals are forwarded to power metering IC in order to get digitized value for further processing. Here RMS value is calculated. Output of power metering IC is serially fed to the controller which consists of information like active power, apparent power.

Figure 4 represents the interfacing of the system in the form of a block diagram. It shows that the controller is interfaced with the ADCs which actually are the internal components of the Energy Metering IC. The Keypad, the LCD are used for the user end, to display the calculated meter readings. The GSM module and the RF module are used for the purpose of communication.

Now microcontroller is programmed such that we get power factor, (SAGS and SWELL in voltages), storing sampled values to calculate average consumption which will further help to estimate average consumption graph, comparing units in case of prepaid billing, etc. Some of the processed data like active power, power factor, reactive power, hourly consumption is made available on LCD so that customer can easily understand power utilization.

As GSM module is used, controller made data available for wireless communication. Customer can get the information about energy consumption through SMS. (The information will be same as displayed on LCD.) So this is two way communication, i.e., between meter and customer and between meter and utility provider. It helps to keep track of power consuming and taking measurements to reduce bill. Also it will be useful to reduce billing fraud and forced extra charges.

Smart meter is equipped with an indication for example a blinking led which will blink only when consumption reaches near to specified value. Also instead of sending a person to cut off supply, work can be done just by sending a SMS in case of overconsumption or if bills are not paid within due date. Information about power billing and power consumption is provided through an SMS using GSM module to customer and administrator, on demand.

B. Common Meter Reading Instrument(CMRI)

One of the important drawbacks of conventional metering system is unnecessary increased man power used in taking meter reading for billing. Physical presence is needed at every site where he/she can take meter readings. This process is little hectic, it takes more time and errors can occur while taking readings.

Power line communication (PLC) is one of the methods used for communication between utility administrator and meter. But data rate and distance between two communication nodes is restricted as it carries low frequency signal on high voltage channel. Also there is major problem of noise interference and data loss due to improper termination and wiring.

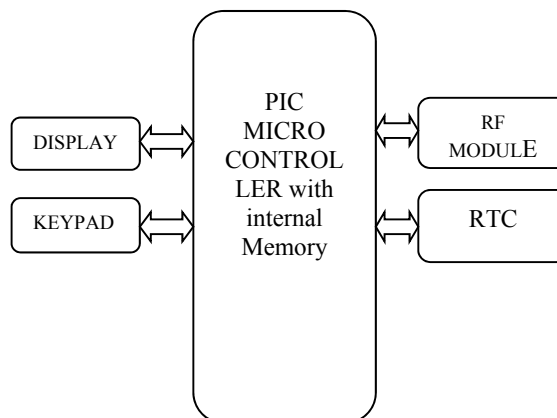

fig.4.CMRI

So to avoid this, CMRI unit can be used. It consists of wireless communication module like Radio Frequency. Here meter reader just visits in vicinity of meter area so that it collects data from meter which will be flawless and work of reader becomes easy.

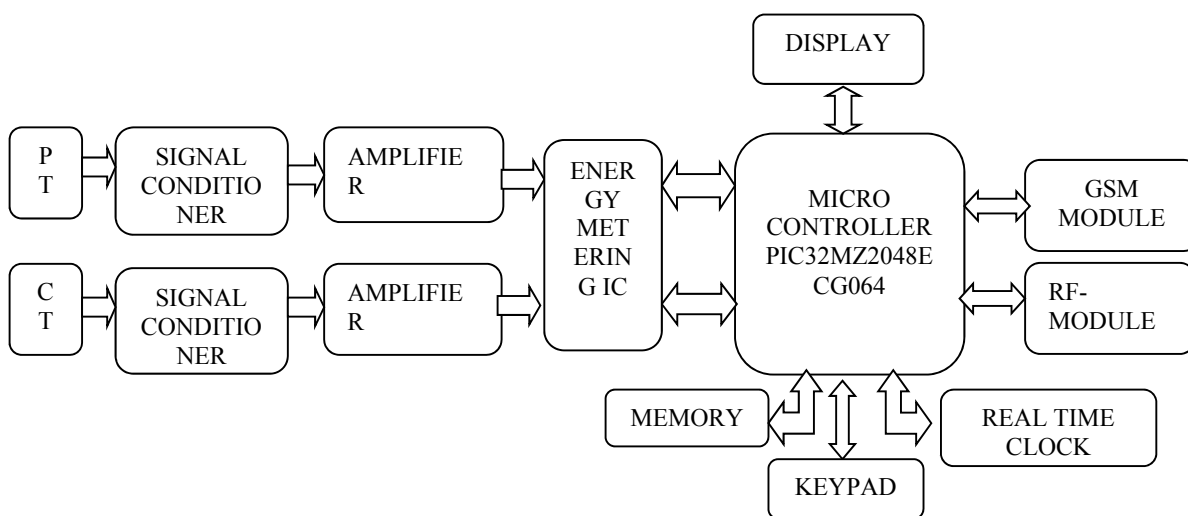

fig.5.block diagram

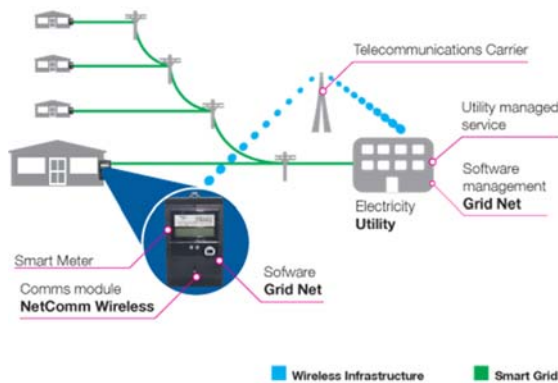

fig.6. communication with grid

V. CONCLUSION

Thus, the energy meter is more efficient than the earlier methods of metering. The energy meter reduces the human errors involved in the earlier methods and introduces RF and GSM techniques of communication. The GSM facility makes the user aware of the amount of energy he/she is consuming so that he can continue to reduce the consumption. Another improvement is the CMRI unit. This unit reduces the human efforts required to obtain the meter readings and further for the billing process. Overall, the system seems to be increasing the efficiency of the Energy Metering and billing process.

References

1. Accuracy of Digital Electricity Meters, Electric Power Research Institute (EPRI)
2. Radio Frequency Exposure Levels from Smart Meters, Electric Power Research Institute (EPRI)
3. No Health Threat From Smart Meters, Klaus Bender, Utilities Telecom Council (UTC)

4. Vinu V Das, "Wireless Communication System for Energy Meter Reading" published in Advances in Recent Technologies in Communication and Computing, 2009. ARTCom '09. International Conference pgs(896-898)
5. 1E.Moni Silviya, 1K.Meena Vinodhini, 2Salai Thillai Thilagam.J. "GSM Based Automatic Energy Meter Reading System with Instant Billing" published in International journal of advance Research in electrical, electronics and instrumentation and engineering(vol.3,special issue 3)
6. A. Arif , Muhannad AI-Hussain, Nawaf AI-Mutairi, "Experimental Study and Design of Smart Energy Meter for the Smart Grid" published in Renewable and Sustainable Energy Conference (IRSEC), 2013 International pgs 512-520
7. "Smart meter based energy management system" by Dr. Péter Kádár
8. "AUTOMATIC ENERGY CALCULATION THROUGH WIRELESS SMART METER USING ZIGBEE" by 1Ms.Karthiga S, 2Mr.Vignesh S, 3Mr Vignesh S, 4Mr.Alex v Stanislavous,5Mr.Kiran Thomas in Vignesh S et al , International Journal of Computer Science & Communication Networks,Vol 3(2), 117-125