



SMART SAILING ROBOT FOR OCEANOGRAPHIC RESEARCH

¹Sonali R. Deshpande, ²Anuradha L. Borkar

Department of E&TC, M.S.S.C.O.E.T., Jalna

Abstract

Over the past decade there has been intense scientific work on autonomous sailing robots. As hardware gets smaller, cheaper and also better performing the possibilities increase for autonomous vessels. Recently there is a lot of research going on with the aim of reducing CO₂ emissions. Smart sailing robot fit perfectly into these ambitions.

A robotic sailboat is able to autonomously navigate towards any given target without human control or intervention. The optimal route is calculated dependent on strategic goals and weather parameters. Rudder and sails are autonomously controlled in order to keep course and to execute maneuvers like tack and jibe. As sailboats operate in a highly dynamic, environment an autonomous sailboat has to respond quickly to ever-changing environmental conditions. Incoming data from sensors (GPS, compass, etc.) have to be analyzed permanently by intelligent control mechanisms.

The best routing decision, perfect handling of ever changing wind conditions and perfect timing during tack and jibe are some of the skills an autonomous sailing vessel has to master.

Keywords: Aurdino, Zigbee, Bluetooth module, GPS, Ultrasonic sensor, IR Sensor, Accelerometer, Waterproof dc servomotors, Battery.

I. Introduction

In this paper we will discuss the main developments of the past years in the field of sailing robot. In this paper the main applications for the use of sailing robot will be introduced with Hardware aspects. The most common boats, sails, microcontrollers and sensors that are used for sailing robot will be discussed. Also contains

an overview about important software architectures for autonomous sailboats. Since the sailing robot needs a reliable connection for monitoring, debugging and remote control in case of emergency, the sailing robot needs a data link to the shore. To detect and avoid obstacles different mechanisms are used. Regarding to that, the collision avoidance chapter will discuss two approaches. The simulation and testing part of the paper will present common simulation methods and testing approaches. The conclusion will summarize the main aspects of this paper.

This is an embedded hardware/software implementation for the computing system of a small scale unmanned autonomous sailing boat. The system is integrated with aurdino, Zigbee tx and rx, Bluetooth module, GPS, Ultrasonic sensor, Accelerometer, Waterproof DC servomotors, 12 V battery supply build in a metallic prototype of boat.

Hardware challenges

Equipping a robotic sailing boat with microcontroller, sensors, actuators and other special hardware needed is very difficult. Waterproofness is a major issue in this context. Sensors have to provide reliable data in an unstable environment. All components have to be small and lightweight enough to be carried by the boat.

Routing algorithms

Routing of autonomous sailing boats is a challenging task since for a sailing boat not every course is directly sailable. There is also a huge difference in the maximum speed a sailboat can reach on a given course. It is also difficult to plan routes because sailboats are operating in an unstable and ever changing environment.

Energy self sufficiency

Autonomous sailing boats used in long term missions on the ocean have to carry all needed energy with them and/or gather energy from the environment.

Collision avoidance

To eliminate the need to monitor robotic sailing boats all the time, they have to be able to avoid collisions with ships and other obstacles in the water.

SAILING MECHANISM

The sailing robot model is made of thin Aluminium Sheet Two brush-less DC motors are fixed to the boat model. Pedals made of MS (Mild Steel) are fixed to the shafts of the DC motors. To move the boat forward, both the motors are operated in clockwise direction by the microcontroller. To move the boat reverse, both

the motors are operated in counterclockwise direction by the microcontroller. To turn left / right, one motor is rotated in clockwise and the other is rotated in counter-clockwise directions. The other key factor which must be considered in designing such a vessel is that of the sail type. Traditional fabric sails are typically controlled through a series of ropes known as sheets and halliards, these frequently break or jam (Particularly when swollen by salt water) and require regular attention from the crew. Performing such tasks autonomously would incur significant overheads resulting in excessive power usage, weight and financial cost. A potential alternative is that of a rigid wing shaped sail attached directly to the mast. The sail is manipulated through the rotation of the entire mast via an electric motor. This design eliminates common points of failure found in traditional Sailing and is therefore ideal for use in an autonomous sailing vessel.

II. Hardware Architecture

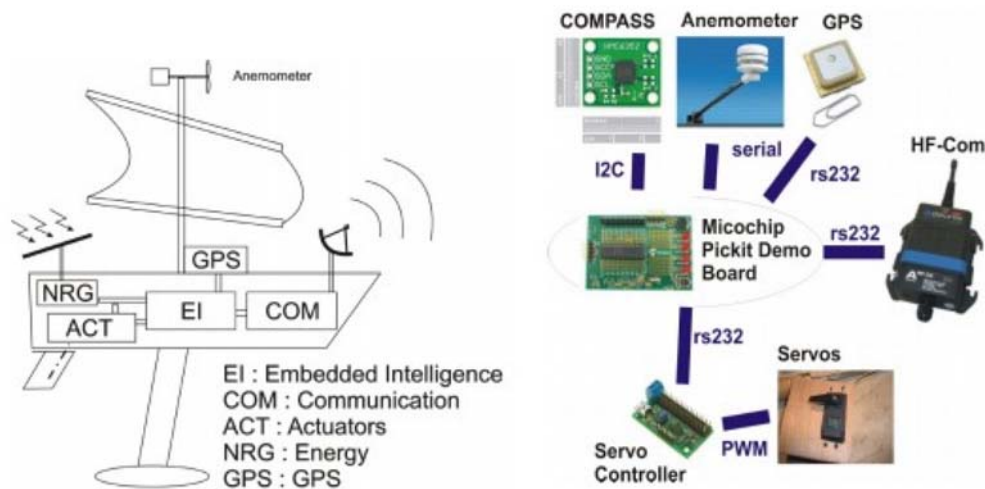

Fig. 1 Hardware Architecture

SAILING ROBOT HARDWARE TOOLS

DC Motors

DC motors are configured in many types and sizes, including brush less, servo, and gear motor types. A motor consists of a rotor and a permanent magnetic field stator. The magnetic field is maintained using either permanent magnets or electromagnetic windings. DC motors are most commonly used in variable

speed and torque. Motion and controls cover a wide range of components that in some way are used to generate and/or control motion.

GPS

GPS has been used for navigating purpose. GPS is mainly used to track the location of robot in ocean and help to navigate in right direction.

Features: Environmental surveillance.

III. SYSTEM BLOCK DIAGRAM:

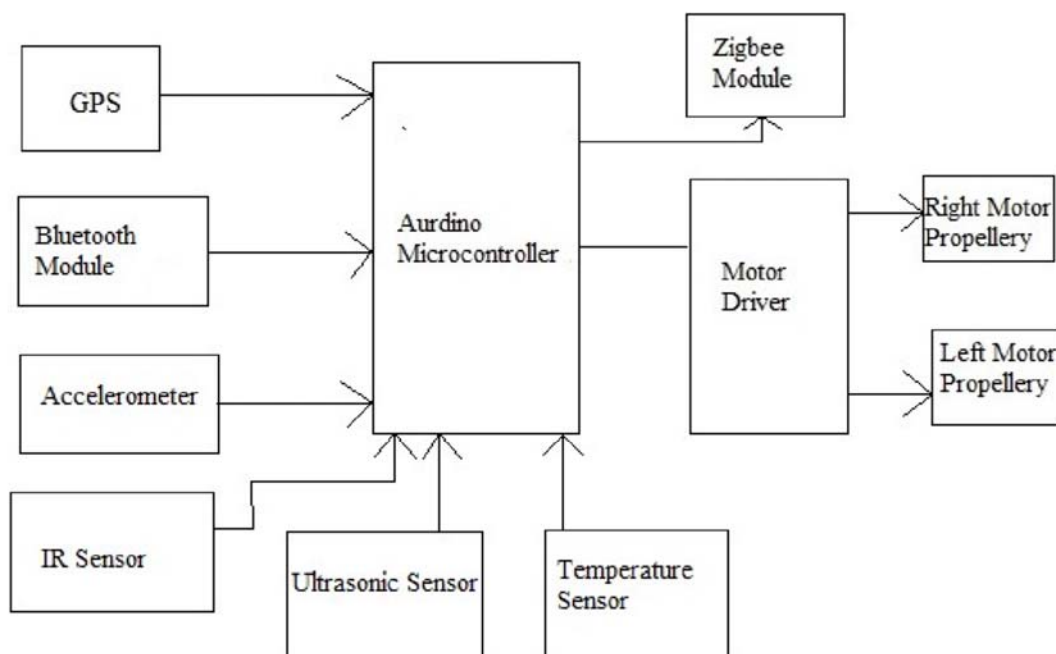

Fig. 2 Block Diagram

This we have the modules of Zigbee, GSM and Sensors which are interfaced with the microcontroller. The sensors used have different activity as per use. Aurdino Microcontroller is the brain of mechanical robot which receives the commands from PC through ZigBee wireless connection and processes these commands to perform pattern motion control. The main part in the robot main board is Aurdino microcontroller which generates two PWM signals for each wheel of DC motor. The two active wheels of the robot are actuated by two independent servo motors modified for continuous rotation. In particular, the robot is powered by 12 V battery. The hardware tools of the robotic system are: ZigBee, Aurdino Microcontroller, DC Motors, Bluetooth Module, Accelerometer, GPS, Ultrasonic Sensor, IR sensor. The hardware components of the robotic system are as shown as above in block diagram.

IV. Related Works

Stelzer et al. also presented a research project where an autonomous sailing boat shall be used for marine mammal research [4]. They use the sailboat for passive acoustic monitoring of marine mammals while reducing the human

impact on them. They state that the advantage of using a robot sailing boat is that the area of interest can be sampled with a very high spacial and temporal resolution for comparatively low cost. They also equipped their boat with additional sensors measuring chlorophyll and zooplankton. An acoustic streamer, three hydrophones, a depth sensor and a compass module are towed behind the sailing vessel.

Cruz and Alves also published a paper on the possible applications of autonomous sailboats for ocean sampling and surveillance [10]. For ocean observation they name upper ocean dynamics, chlorophyll concentration, ocean acoustics, calibration of basin-wide ocean models and tracking of pollution plumes as fields of interest for scientists where robotic sailboats can collect required data for low costs. In the field of surveillance the authors state that autonomous sailing boats can be used for the detection and prevention of illegal trading, surveillance of immigration routes and assistance in the detection and disarming of minefields in the ocean.

V. Applications and Advantages of sailing Robot

There are several possible fields of application for autonomous sailing boats.

- Intelligent Sensor Buoys:

Autonomous sailing boats can easily be equipped with several sensors measuring all kinds of data. As they are energy self sufficient their operation time is not limited. Therefore, it is very cost efficient to use them for surveys, mappings and ecological studies of oceans and lakes. Ocean sampling and marine mammal research are two applications where already projects exists to facilitate robotic sailboats.

- CO₂-neutral in Transportation of Goods:

Conventional sailboats are unprofitable for the transportation of goods nowadays because they need a very big crew to be operated. Autonomous sailing boats do not suffer from that disadvantage and can therefore be used for the CO₂-neutral transportation of goods.

- Reconnaissance and Surveillance:

Sailing robots can also be sent to operate in dangerous regions. For example, they could be used to measure the nuclear radiation in the ocean near Fukushima. Another application would be the surveillance of the borders in the Mediterranean sea.

- Supply Vessel:

Remote islands and regions that are sparsely populated could be supplied using robot sailing boats. For example, they could be used to supply scientists that work on small islands in the arctic ocean.

- Obstacle detection:

Their algorithm uses a map of the coastline that could also be extended to work with other sensed obstacles. The sailboat determines its position on the map using a positioning system (e.g. GPS) and then casts rays from the robots position in every direction (every angle from 0-359 degrees) and senses the distance to the nearest obstacle in that direction.

Once an obstacle is detected a new course is decided that avoids the obstacle. Collision avoidance is a challenging task for autonomous sailboats as they operate in an ever changing, unstable environment. Sailboats can change their route.

- Communication:

A permanent data link between boat and shore is necessary for monitoring, debugging, to control manually in case of emergency, for real-time monitoring. Real-time measurement data are needed for long-term observation tasks. Three communication partners are involved in the communication process.

1) Sailboat: The sailboat transmits sensor values to the visualization.

2) Visualization software: This computer program runs on a computer on the shore and represents the transmitted data. Furthermore, new target coordination, obstacle information or a new desired course can be sent from the visualization to the sailboat.

3) Remote controller: This entity can be used in case of emergency to overrule the autonomous on-board control of the sailboat. It is especially needed during test runs. Desired actuator values like position of the rudder and sails are transmitted in real time to the sailboat.

VI. Conclusion and Future work

The Smart sailing robot for oceanographic research is used to explore all the details on the surface of the water. This robot is used for locating the position of the system using GPS, detects metals present in the ocean and used for surveillance and rescue operation.

In this paper, we introduce a successful working prototype model of manoeuvre sailing mobile robot is designed for oceanographic research. An autonomous sailing robot offers major advantages compared to submerged operated vehicles. It tracks the movement with the help of wireless cam attached to the robot through RF PRO wireless sensor network. The surface environment of ocean i.e., ocean exploration and navigational research can be studied through wireless cam, GPS, Metal detector , IR sensors, Ultrasonic sensors interfaced to the robot. Further development is required to demonstrate the feasibility of a sailing robot for long term use in open sea and helpful for oceanographers and scientists.

REFERENCES

- [1] M.P. Khorgade "Application of MEMS in Robotics and Bio MEMS", Proceedings of the UK sim 13th international conference.

- [2] World robot sailing championship, 2011. <http://www.wrsc2011.org/>.
- [3] Mobile Robotic “ Navigation and control for large-scale wireless sensor network repair”, by Kyle lathy in north Carolina state university on may6, 2009
- [4] H. Klinck, Roland Stelzer, K. Jafarmadar, and D.K. Mellinger. Aas endurance: An autonomous acoustic sailboat for marine mammal research. In Proceedings of International Robotic Sailing Conference, pages 43{48, Matosinhos, Portugal, July.2010. Queen's University.
- [5] Razavi,” RF Transmitter Architectures and circuits”, IEEE CICC, pp.197-204, 1999
- [6] M.P. Khorgade “Application of MEMS in Robotics and Bio MEMS”, Proceedings of the UK sim 13th international conference.
- [7] Mobile Robotic “ Navigation and control for large-scale wireless sensor network repair”, by Kyle lathy in north Carolina state university on may6, 2009
- [8] L Giger, S Wismer, S Boehl, G Buesser, H Erckens, J Weber, P Moser, P Schwizer, C Pradalier, and R Siegwart. Design and construction of the autonomous sailing vessel avalon. In Proc. of The World Robotic Sailing Championship and International Robotic Sailing Conference, 2009.
- [9] Henly, J. (2006). An Artificial Neuroendocrine Kinematics Model for Legged Robot Obstacle Negotiation. PhD thesis, University of Wales, Aberystwyth
- [10] Nuno A. Cruz and Jose C. Alves. Ocean sampling and surveillance using autonomous sailboats. In Proceedings of International Robotic Sailing Conference, pages 30{36, Rua Dr. Roberto Frias, 4200-465, Porto - Portugal, May 2008. Department of Electrical and Computer Engineering Faculty of Engineering of the University of Porto.