



AN INTELLIGENT NEURAL NETWORK BASED LOAD SHARING FOR A HOME USER

Chinnu Mariam Baby ¹, Midhu Das B ²

EEE Dept, Amal Jyothi college of engineering , Kanjirapally,

Student ¹, Assistsnt Professor ²

Email: chinnu19.9.91@gmail.com¹, midhudasb@amaljyothi.ac.in²

Abstract- Energy demand is increasing rapidly with the intensive growth of economy. The electricity demand is exceeding the availability, both in terms of base load energy and peak availability. The efficient energy management systems and usage of renewable energy resources are the viable alternatives available to bid the energy supply and demand gap. Requirement has increased for renewable sources of energy to be utilized along with conventional system to meet the energy demand. This thesis proposes a data-enabled predictive energy management strategy for a smart home that includes a photovoltaic system and grid supply. The load sharing is done based on data-based forecasting of future load demand and PV generation. Specifically, a load demand forecast model and PV generation model is developed using an artificial neural network (ANN). The forecast model predicts the load demand signals for a smart home to shave the peak demand and to shift the consumption from renewable source.

Keywords – Demand Side Management (DSM); Load forecasting; PV prediction; Peak shaving; Load sharing

1. INTRODUCTION

Electricity has a peculiar characteristic that it cannot be economically stored in large quantities. Electricity demand is the fastest growing form of energy consumed worldwide and it is predicted that the worlds net electricity consumption will double by 2030 [1]. Therefore its generation and consumption need to be

matched at all times. Conservation is the most economical, straightforward and effective means of reducing reliance on fossil fuels. Demand Side Management (DSM) refers to the ability to alter end user electrical consumption in response to system conditions [2]. DSM activities are designed to encourage customers to modify their patterns of electricity usage and to use energy efficient appliances so as to match the level of electricity demand with availability.

DSM programs play an important role in mitigating electrical system emergencies, avoiding blackouts and increasing system reliability, reducing dependency on expensive imports, reducing high energy prices, providing relief to the power grid and generation plants, avoiding high investment in generation, transmission and distribution network and leading to environmental protection. DSM programs are designed to save money for all consumers besides protecting the environment [2]. Energy efficiency and Demand Side Management (DSM) have significant potential in India. The need for affordable electricity and the energy and peak shortages make DSM important for India. The rationale for DSM can be justified when we weigh other load management or more precisely supply management alternatives from the perspective of the utility, customers and society.

The residential sector is currently one of the major contributors to the global energy balance. However, the energy demand of residential users has been so far largely uncontrollable and inelastic with respect to the power grid

conditions. With the massive introduction of renewable energy sources and the large variations in energy flows, also the residential sector is required to provide some flexibility in energy use so as to contribute to the stability and efficiency of the electric system[8]. To address this issue, demand management mechanisms can be used to optimally manage the energy resources of customers and their energy demand profiles [9].

Economic viability and reliability of private electricity generations depend critically on the energy management scheme, which determines flows of power between generation, loads, and storage. However, optimal energy management is complicated by uncertainty in environmental conditions, load demand, and battery ageing. In this thesis, we develop a predictive energy management scheme for a home with photovoltaics (PV) and grid supply, using data-based forecasting of PV generation and load demand. The main contribution of this paper is to systematically address load and solar power uncertainty by incorporating forecasting methods into load sharing strategy of smart home energy management.

2. This paper is organized as follows.

Section 2 provides an overview system where energy management strategy is applied. Section 3 describes the proposed work and explains the energy management strategy and its implementation into a control algorithm and also presents the Simulation results. Section 4 discuss about the hardware prototype. Finally in Section 5, some concluding remarks are made and future work directions are proposed. SYSTEM STUDY

System under consideration is normal residential user with sources: solar PV, grid, battery and sinks: AC & DC loads. Home user consumes the grid power based on normal utility tariff and it has a private roof top solar panel system. A battery back-up is also provided.

2.1. PV system

Here a 2.5 KW Off grid solar PV system consisting of 12 panels each of 220Wp is considered. The PV system includes a 5Kva inverter and 8 solar tubular lead acid batteries.

Panel specifications (at 1000 W/m² solar radiation):

- Maximum power, P_{max} - 220 WP
 - Optimum operating voltage, V_m -27.1 V
 - Optimum operating current, I_m -8.12 A
 - Open circuit voltage, V_{oc} -34.06 V
 - Short circuit current, I_{sc} -8.48 A
 - Cell efficiency-16.7
- a. Number of panels

Average daily load consumption =13 units By thumb rule, a 100 W panel generates 0.5 units. So, for generating 13 units, 2600W panel is required. The rating of one panel is 220 W. Thus the number of panels required for generating 2600W is 12.

b. Number of batteries

The Ah rating and number of batteries required are determined based on the load requirement. For this system, 8 number of 150Ah Exide Solar tubular lead acid batteries are used. Since the voltage of one battery is 12V, total battery voltage is 96V.

c. Panel connection

Total panel voltage should be 25 -50 % greater than battery voltage. Thus 6 panels are connected in series which gives an output voltage of 162.6V which is 41 % greater than battery voltage. Thus 6 panels in series are connected in parallel with other 6 panels in series. So the output current becomes 16.24A ($2 \times 8.12A$). The total power produced from the panels is $16.24 \times 162.6 = 2640.624W$ which is same as obtained from panel rating ($220 \times 12 = 2640W$).

2.2. Appliance consumption profile

Most of the currently available energy management systems in domestic environment are concerned with real-time energy consumption monitoring, and display of statistical and real time data of energy consumption. Although these systems play a crucial role in providing a detailed picture of energy consumption in home environment and contribute towards influencing the energy consumption behaviour of household, they all leave it to households to take appropriate

measures to reduce their energy consumption. Some energy management systems do provide general energy saving tips but they do not consider the household profiles and energy consumption profiles of home appliances. The proposed system attempts to address this issue by taking into account household energy consumption profiles of electrical appliances.

Energy audit is the preliminary step in the process of energy conservation. By conducting an energy audit, the consumer can analyse his energy consumption pattern and can make note of the possibilities that exist in conserving the electricity. Here the electricity consumption of a three bedroom residential house is analysed for a period of one month and a load curve is estimated for that building. Preliminary survey of the building is done, all the appliances in use are accounted and estimation of energy consumed is evaluated.

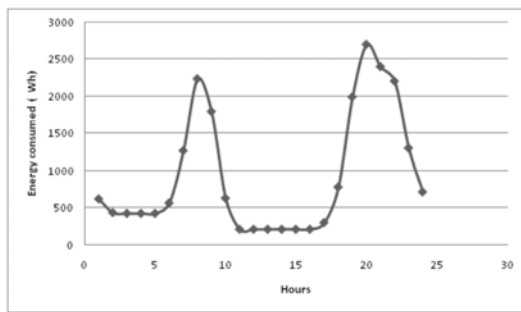

Fig.1: Hourly load curve

Total connected load = 8132 W By noting the consumption pattern of appliances load curves for week days and weekends can be drawn. Fig. 1 shows the load curve for Monday of first week of the month. Similarly load consumption profile for entire month evaluated. This data is used to train the neural network for load prediction. Also PV generation prediction for the home user is done using generation pattern for a 2.5 kW PV system for one month.

3. PROPOSED WORK

3.1. Proposed algorithm

The smart house peak shaving energy management system consists of a wired network that connects the house applications to a personal computer with a custom relay and sensing electronic boards that controls driving AC power to the house applications. A dedicated control and scheduling programs were designed and implemented to handle all the tasks. An energy consumption scheduling algorithm is proposed

with load and two resources. Our algorithm is designed to minimize the peak demand of a residential user. For this the expected load and PV power is forecasted for the future time slots [7]. Proposed design can incorporate both load and supply uncertainties, and leads to a reduction of the energy bills of users. Furthermore, the proposed approach improves the overall power system performance by reducing the peak-to-average ratio (PAR) of the aggregate load demand. It also facilitates a more efficient utilization of the RERs by encouraging the users to shift their load to time slots with high renewable power generation and thus, enables a reduction of the amount of energy that has to be imported from the power grid.

The proposed algorithm is shown below;

1. Start
2. Check whether time between (9am-4pm), if no go to step 13
3. Calculate P_{peak} ; $P_{predicted}$ and P_{PV} predicted; $P_{target} = 0.75P_{predicted}$
4. Check whether $P_{peak} > 0.75 P_{target}$; if no go to step 8
5. Check whether PPV predicted $> P_{peak}$; if no go to step 12
6. Switch medium loads to PV system
7. Go to step 3
8. Check whether $P_{peak} > 0.5 P_{target}$; if no go to step 3
9. Check whether $(P_{PV} \text{ predicted} - P_{med}) > P_{peak}$; if no go to step 12
10. Switch light loads to PV system
11. Go to step 3
12. Alert user
13. Time check whether time between (7pm-10pm), if no go to step 15
14. Switch only light loads to grid and medium loads to PV system
15. Calculate P_{peak} and P_{Bat}
16. Assign $P_{target} = 0.75 P_{PV}$ predicted
17. Check whether $P_{peak} > 0.75 P_{target}$; if no go to step 21
18. Check whether $P_{Bat} > P_{peak}$; if no go to step 25
19. Switch medium loads to PV system
20. Go to step 15
21. Check whether $P_{peak} > 0.5 P_{target}$; if no go to step 15
22. Check whether $(P_{Bat} - P_{med}) > P_{peak}$; if no go to step 25
23. Switch light loads to PV system
24. Go to step 15

25. Alert user
26. Go to step 2

3.2. Load prediction using artificial neural network

Load Forecasting is an important component for power system energy management system. Load forecasting means predicting the future load with the help of historical load data available. It is very important for the planning, operation and control of power system. Load Forecasting can be performed using many techniques such as similar day approach, various regression models, time series, statistical methods, fuzzy logic, artificial neural networks, expert systems, etc. But application of artificial neural network in the areas of forecasting has made it possible to overcome the limitations of the other methods mentioned above used for electrical load forecasting. The most important aspect of artificial neural network in STLF is that a single architecture is used with same input-output structure for predicating hourly load of various size utilities [3]. In this case consumer is a home user. 24 hours load data is taken for four weeks as the historical data.

In training process, transfer functions used are tansig for hidden layer and purelin for output layer. The learning function Levenberg-Marquardt is used due to its better learning rate as compared to other functions in forecasting problems. In training process, the following parameters are used:

No. of Epochs = 84

Learning rate parameter = 1

The results obtained from trained ANN model includes the general network error performance, regression analysis between output and target vector and also include training state. The input data set is divided into three parts: 70% data is used to train the network, 15% used for testing and another 15% used for validation. During training process, training data set is used for obtaining weight and bias value of neural network. To test periodically ability of network, validation data set are required. Finally, test data set used to evaluate the error (MSE). The input data of 24 hourly loads are taken for a home consumer.

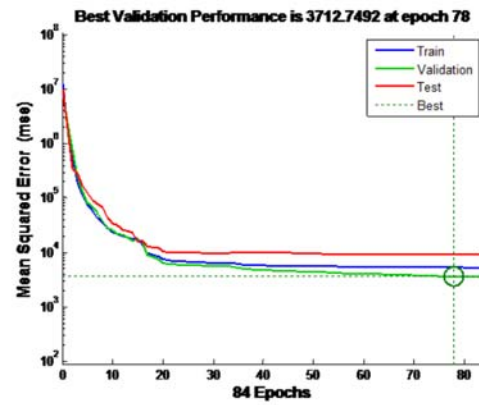

Fig.2: Performance plot

The Performance function (MSE) Vs number of epochs in Fig. 2 plot describes the plot of the mean squared error against the number of training epochs. It also shows the learning trend and computational error improvement as the number of iterations increases. As the no. of iterations increases computational error considerably improves. Network can be said to have successfully learned any complex and non linear relationship that was presented by the input data.

The choice of the number of hidden layer neurons, layer transfer function(s), training function, learning function, network architecture and other network and training parameters is a trial and error approach until the best set is attained [4].

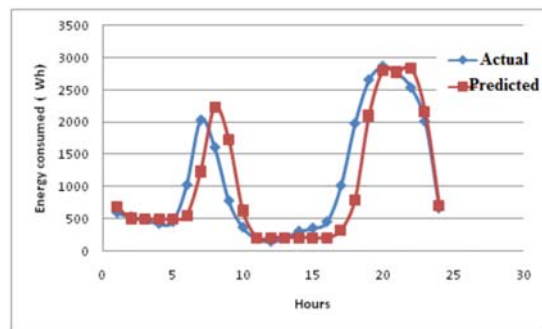

Fig.3: Comparison plot of load prediction

A forecasted result for a day is shown above. The plot seems to follow the actual load curve.

3.3. PV power prediction using artificial neural network

Artificial neural network is used for forecasting the solar power generation of a solar

power plant. In this process we need plant generation data [5]. Short term energy data recorded in each one hour interval for AC power output for March 2015 is used as the data. In this paper Multilayered feed-forward neural network is used for solar power forecasting modelling. And following specific selection of neurons and layers provides better result.

- Number of input variable = 2
- Number of output = 1
- Number of input layer = 1
- Number of Hidden layer neurons = 15

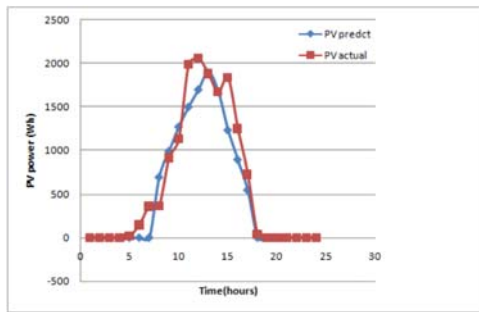

Fig. 4: Comparison plot of PV prediction

In Fig. 4 actual data is compared with testing performance of ANN model.

ANN models like all other approximation techniques have relative advantages and disadvantages. There are no rules as to when this particular technique is more or less suitable for an application [6]. Result of ANN depends upon number of hidden layer neurons. In order to get optimize result we should select optimize number of hidden layer neurons. One way of selecting hidden layer neuron using optimize algorithm technique and other way is hit and trial method [4]. In this proposed model hit and trial method has been used but it is never easy to comment that the used number of hidden neurons is perfect.

3.4. Proposed system model

In this paper an intelligent load sharing is proposed. There are three time slots involved in the algorithm, peak time, morning and midnight, daytime. Fig. 5 shows the simulink model for the proposed system. Two main inputs are day and date. ANN predicts the load curve and system will switch the loads according to the algorithm. Initially light loads will be switched and further

switching of medium loads will be done if required.

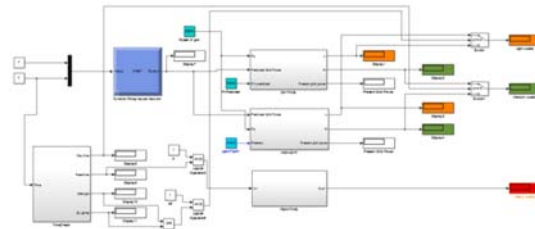

Figure 5. Simulink model for proposed system

Load curve after the implementation of proposed system is shown in Fig. 6.

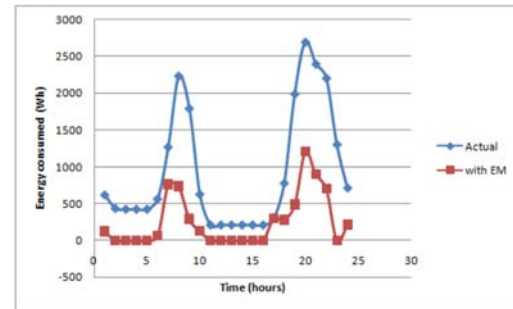

Fig. 6: Comparison plot of actual and proposed system

Energy consumption profile has seemed to be reduced from the plot. The proposed system enables the monitoring of load sections to get intelligently shared between PV and grid.

4. HARDWARE PROTOTYPE

The simulation results were verified experimentally by the hardware prototype. The proposed algorithm is tested and the output was verified. Serial communication with system and relay control was made by interfacing the Matlab/Simulink using Arduino Mega.

The overall architecture of the proposed system is shown in Fig. 7. The main components of the architecture are a rule based system. We have defined a set of rules concerning light, medium and heavy loads and the abnormal activities that may occur. Relay operation will be done based on the control algorithm rules.

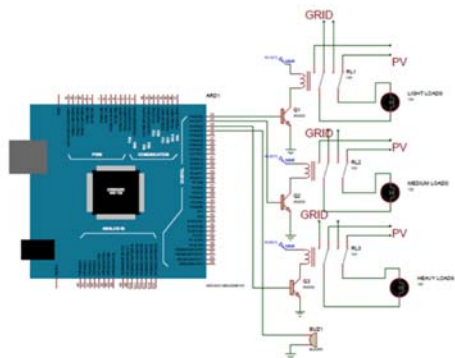

Fig.7: System architecture

The Arduino Mega is a microcontroller board based on the ATmega2560. It has 54 digital input/output pins (of which 14 can be used as PWM outputs), 16 analog inputs, a 16 MHz crystal oscillator, a USB connection, a power jack, an ICSP header, and a reset button. It contains everything needed to support the microcontroller; simply connect it to a computer with a USB cable or power it with a AC-to-DC adapter or battery to get started.

The Mega differs from all preceding boards in that it does not use the FTDI USB-to-serial driver chip. Instead, it features the Atmega8U2 programmed as a USB-to-serial converter. The Arduino Mega can be powered via the USB connection or with an external power supply. The power source is selected automatically. The Arduino Mega can be powered via the USB connection or with an external power supply. The power source is selected automatically. External (non-USB) power can come either from an AC-to-DC adapter (wall-wart) or battery. The adapter can be connected by plugging a 2.1mm centre positive plug into the board's power jack. Leads from a battery can be inserted in the G_{nd} and V_{in} pin headers of the power connector. The board can operate on an external supply of 6 to 20 volts. Here Arduino Mega Microcontroller board is used as the serial data connector between system and relay control circuit.

Proposed load sharing algorithm is validated using MATLAB/Simulink simulations. Also the experimental setup verifies the proposed algorithms output. Relay operation was found validating for the control of light and medium load.

5. CONCLUSION

A smart house is a good choice for people caring about security, health, energy saving and convenience. The role of a smart house system dedicated to power management is to adapt the power consumption to the available power resources, and vice versa, taking into account inhabitant comfort criteria. Such methods for controlling electricity consumption are part of demand response, which reduce peak demand. Reduced peak demand lowers electricity bills and benefits utilities by reducing complexity of grid stability, occurrences of equipment failures, brownouts, and blackouts. Peak shaving procedure will lower total energy consumption, reduce the cost of the power from the national grid through the use of renewable resource and through the shift of high power devices to the night where the power cost is lower and actively manage other usage to respond to solar PV system.

This proposed system introduces a peak shaving energy management system that reduces peak demand of the power usage, shares the usage with available PV power. Constraints such as due time of a process, limit of electrical energy consumption and use of preferable resources are taken into account. ANNs have been applied in prediction of load profile and available PV power. What is required for setting up such systems is data that represents the past history and performance of the real system and a suitable selection of ANN models. Estimation of Energy savings potential (ESP) for the proposed system have been observed from the plot for energy consumption after load sharing and a prototype of the system was also developed in the laboratory.

REFERENCES

- [1] Ministry of power, Growth of Electricity Sector in India from 1947-2015, Central Electrical Authority India, June 2015.
- [2] Steve Nadel, Yang Zhirong, and Shi Yingyi, Integrated Resources Planning and Demand Side Management Manual for China and Other Developing Countries, ACEEE, 2004.
- [3] D. K. Chaturvedi, Sinha Anand Premdayal, Ashish Chandiok, "Short-Term Load Forecasting Using Soft Computing Techniques "Int. J. Communications,

- Network and System Sciences, 273-279, March 2010.
- [4] Paras Mandal, Tomonobu Senjyu, Naomitsu Urasaki, Toshihisa Funabashi, "A neural network based several-hour-ahead electric load forecasting using similar days approach", *Electrical Power and Energy Systems*, 367373, 2006.
- [5] Diagne H, David M & Boland J, "Solar irradiation forecasting: State-of-the-art and proposition for future developments for small-scale insular grids. *American Solar Energy Society*", 2012.
- [6] F. Almonacid, C. Rus, P.J. Perez, L. Hontoria, "Estimation of the energy of a PV generator using artificial neural network", *Renewable Energy*, 34(12), 2743-2750, 2009.
- [7] Xin Liu, Liviu Ivanescu, Rui Kang, and Martin Maier, Real-time Household Load Priority Scheduling Algorithm based on Prediction of Renewable Source Availability", *IEEE Transactions on Consumer Electronics*, Vol. 58, No. 2, May 2012.
- [8] M. Negnevitsky, *Artificial Intelligence: A Guide to Intelligent Systems*, Addison Wesley, Boston, 2004.
- [9] Davide Caprino, Marco L. Della Vedova, Tullio Facchinetti, "Peak shaving through real-time scheduling of household appliances", *Science Direct Energy and Buildings*, 75, 133-148, 2014.