



INTELLIGENT WATER PUMP CONTROLLER

¹B.Priyanka, ²M.Himavarsha, ³G.Srividhya, ⁴G.Sathish, ⁵A.Anroop, ⁶K.B.V.S.R.Subrahmanyam
^{1,2,3,4,5}SR Engineering College, final year EEE students.

⁶Associate Professor, HOD, SR Engineering College, EEE Department.
Email: ¹byrojudpriyanka@gmail.com, ⁶libra_22@rediffmail.com

Abstract

Now-a-days most of the people are busy with their works. They are forgetting to turn off the motor even after the overhead tank gets overflowed due to which there is a wastage of water and the power. Instead of using two controllers to operate two motor automatically for ON and OFF we are using only one controller.

And to know whether the tank is filled or not in case of building with more than one floor it is impossible. So, our project intelligent water pump controller will provide the solution to overcome this problem.

It consists of three sensors of which two are placed in overhead tank at maximum and minimum levels. Another sensor is placed in sump. Whenever, we turn ON the sump motor the water starts flowing into overhead tank and whenever the overhead tank gets overflowed then the sensors in overhead tank gets in contact with each other and the motor gets automatically turned OFF.

In any situation if the sump gets empty the sensor gets dried and the motor gets automatically turned OFF and by using the change over switch automatically the bore well pump gets turn ON and the overhead tank starts filling with water and whenever the overhead tank gets overflowed the motor gets turned OFF automatically.

I. INTRODUCTION

People generally switch on the pump when their taps go dry and switch off the pump when the overhead tank starts overflowing. This results in the unnecessary wastage and sometimes non-availability of water in the case of emergency.

The circuit that we are using makes this system automatic, i.e. it switches on the pump when the water level in the overhead tank goes low and switches it off as soon as the water level reaches a predetermined level. It also prevents 'dry run' of the pump in case the level in the tank goes below the suction level.

Water Level Controller employs a simple mechanism to detect and maintain the water level in a tank or any other container by switching it on/off the motor automatically when needed. The level sensing is done by three sensors which are placed at different levels on the tank walls.

The three sensors are placed as following:

Sensor C- At the bottom of the tank.

Sensor B- A little above of sensor 1.

Sensor A-At the top of the tank.

The three sensors are maintaining the water level in the tank by triggering & retriggering the timer IC. Here the timer IC is acting in monostable mode or one-shot mode. Sensor C carries the +Vcc supply thus when the water level falls below sensor B the timer IC is triggered & the pump is energized through a relay & transistor. Now when the water reaches the topmost level & touches sensor A it retrigger the timer IC once again & the pump is switched off automatically. Hence this water level controller is one of the cheapest & simplest devices which prevents wastage of both electricity & water.

II. DESCRIPTION

RESISTORS: A resistor is a two-terminal electronic component designed to oppose an electric current by producing a voltage drop between its terminals in proportion to the current, that is, in accordance with Ohm's law:

$$V=IR$$

Resistors are used as part of electrical networks and electronic circuits. They are extremely common place in most electronic equipment. Practical resistors can be made of various compounds and films, as well as resistance wire.

TRANSISTORS: The BC547 transistor is an NPN Epitaxial Silicon Transistor. The BC547 transistor is a general-purpose transistor in small plastic packages. It is used in general-purpose switching and amplification BC547 series 45 V, 100 mA, NPN general-purpose transistors.

DIODES: Diodes are used to convert AC into DC these are used as half wave rectifier or full wave rectifier. When used in its most common application, for conversion of an alternating current (AC) input, into a direct current (DC) output, it is known as a bridge rectifier provides full-wave rectification from a two-wire AC input, resulting in lower cost and weight as compared to a rectifier with a 3-wire input from a transformer with a center-tapped secondary winding.

CAPACITOR: A capacitor or condenser is a passive electronic component consisting of a pair of a conductors separated by a dielectric. When a voltage potential difference exists between the conductors, an electric field is present in the dielectric. This field stores energy and produces a mechanical force between the plates. The effect is greatest between wide, flat, parallel, narrowly separated conductors.

VOLTAGE REGULATOR:

The LM78XX/LM78XXA series of three terminal positive regulators are available in the TO220/D-PAK package and with several fixed output voltages, making them useful in a wide range of applications. Each type employs internal current limiting, thermal shutdown and safe operating area protection, making it essentially indestructible if adequate heat sinking is provided, they can deliver over 1A output current.

RECTIFIER: A rectifier is an electrical device that converts alternating current (AC), which periodically reverses direction, to direct current (DC), current that flows in only one direction, a process known as rectification.

III.WORKING

POWER SUPPLY CIRCUIT:

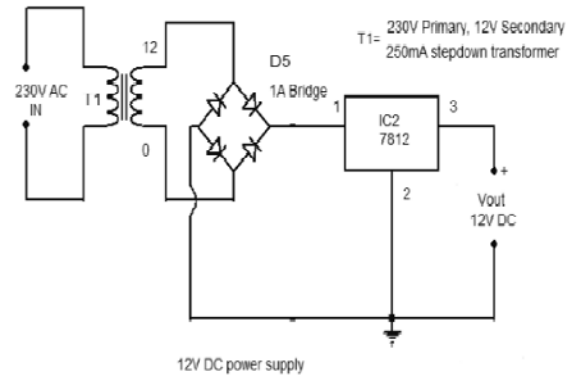

POWER SUPPLY: The circuit uses standard power supply comprising of a step-down transformer from 230V to 12V and delivers pulsating dc which is then filtered by an electrolytic capacitor of 2200µF. The filtered dc being unregulated, IC LM7812 is used to get 5V DC constant at its pin no 3 irrespective of input DC varying from 7V to 15V. The input dc shall be varying in the event of input ac at 230volts section varies from 160V to 270V in the ratio of the transformer primary voltage V1 to secondary voltage V2 governed by the formula $V1/V2=N1/N2$. As $N1/N2$ i.e., number of turns in the primary to number of turns in the secondary remains unchanged V2 is directly proportional to V1. Thus if the transformer delivers 12V at 220V input it will give 8.72V at 160V. Similarly at 220V it will give 14.72V. Thus the dc voltage at the input of the regulator changes from about 8V to 15V because of AC voltage variation from 160V to 270V the regulator output will remain constant at 12V.

The regulated 12V DC is further filtered by a small electrolytic capacitor of 0.01µF for any noise so generated by circuit. One LED is connected of 1KΩ to the ground i.e., positive voltage to indicate 12V supply availability.

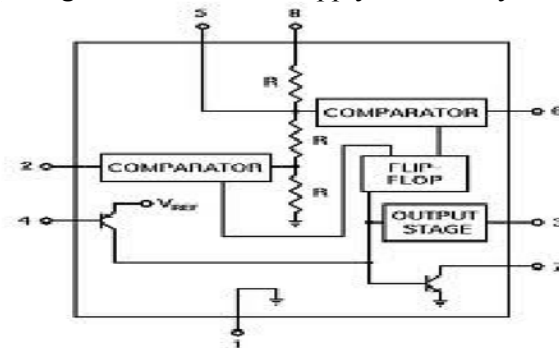

Internal circuit of 555 Timer IC

555 TIMER IC: The 555 timer IC is an integrated circuit used in variety of timer, and oscillator applications. The 555 timer can be used to provide time delays, as an oscillator and as a flip-flop element. The NE555 parts were commercial temperature range 0°C to +70°C, and the SE555 parts number designated the military temperature range of -55°C to +125°C. These were available in both high-reliability metal can and inexpensive epoxy plastic package. The full part numbers were NE555V, NE555T, SE555V and SE555T

MONOSTABLE MODE OF 555 TIMER IC: In our water level controller timer IC works on mono stable mode. In this mode, the 555 functions as a one-shot pulse generator. The pulse begins when the 555 timer receives a signal at the trigger input that fall below a third of the voltage supply. The width of the output pulse is determined by the time constant of an RC network, which consists of a capacitor and a resistor. The output pulse ends when the voltage on the capacitor equals 2/3 of the supply voltage. The output pulse width can be lengthened or shortened to the need of the specific application by adjusting the values of R and C.

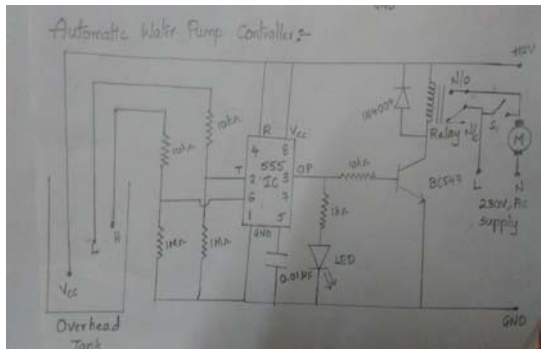

Automatic water pump controller

IV. OPERATION

The property of 555 Timer IC is that the output goes to HIGH when voltage at the second pin (trigger pin) is less than $V_{cc}/3$. And also we can reset back the IC by application of a low voltage at the fourth pin (reset pin). In this project 3 wires are dipped in water tank. Let us define two water levels bottom (L) level and top (H) level. One of the wire or probe is from V_{cc} which can be called as middle level. The probe from bottom level is connected to trigger pin of 555 IC. So, the voltage at the trigger pin is V_{cc} when it covered by water. When water level

goes down, the trigger pin (2nd pin) gets disconnected from water i.e., voltage at the trigger pin becomes less than V_{cc} then the output becomes high. Then the output of 555 IC is fed to a transistor so that it energizes the relay coil and water pump set is turned ON.

While the water level rises, the top level probe is covered by water and the transistor becomes ON. Its collector voltage goes to V_{cc} (sat) = 0.2V. The low voltage at the 4th pin resets the IC. So that output of 555 IC becomes 0V. Hence the motor will turn OFF automatically.

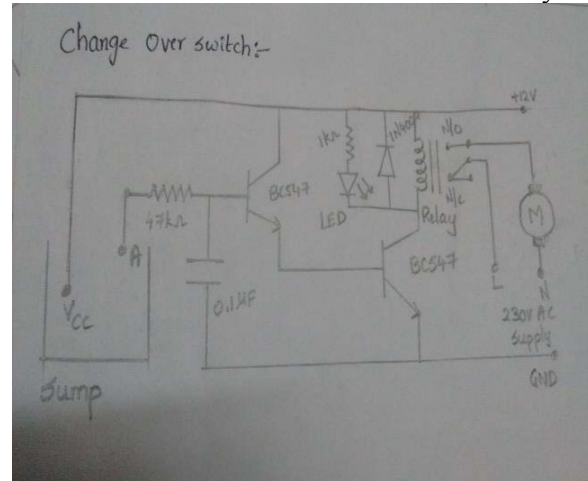

In any situation if the sump gets empty the sensor gets dried and the motor gets automatically turned OFF and by using the change over switch automatically the bore well pump gets turn ON and the overhead tank starts filling with water and whenever the overhead tank gets overflowed the motor gets turned OFF automatically.

For practical implementation, relay is used. Rating of relay is chosen according to the load (motor). 32 Ampere relay is best suited for domestic applications.

V. RESULTS AND DISCUSSIONS:

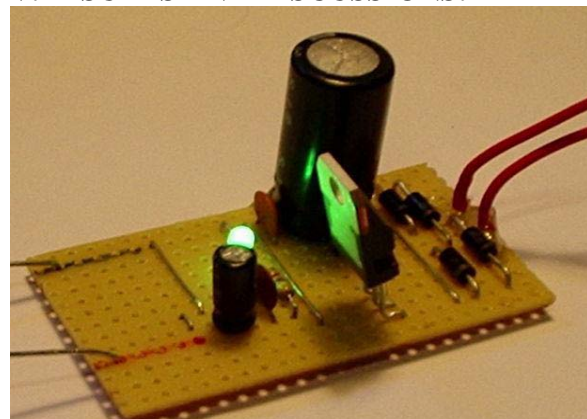



REFERENCES:

- [1] Joydeep Kumar Chakraborty “water pump controller”.
- [2] Ward, Jack (2004), the 555 timer IC.

WEBSITES:

- www.ebookbrowse.com
- www.electronicstoy.com
- www.digitek.in
- www.sridigitek.com



Output during the operation of the water pump

The experimental model was made according to the circuit diagram and the results were as expected. The motor pump switched ON when the OHT was about to go dry and switched OFF when the OHT was about to overflow.

This system is very beneficial in rural as well as urban areas. It helps in the efficient utilization of available water sources. If used on a large scale, it can provide a major contribution in the conservation of water for us and the future generations

VI.CONCLUSION:

This project of INTELLIGENT WATER PUMP CONTROLLER is a cost effective, practical, eco friendly and safest way to save energy. It clearly tackles two problems that world is facing today, saving of energy and also water very efficiently.

The project has the scope in various other applications like it can be used in apartments, hotels, hospitals and incase of building with more than one storey.

ACKNOWLEDGEMENT:

We are thankful to the management of SR Engineering College, Warangal for providing facilities to publish this work.