



DEVELOPMENT OF CLOUD-BASED LIGHT INTENSITY MONITORING SYSTEM FOR GREEN HOUSE USING RASPBERRY PI

Sandip Balaso Khot¹, Dr. M. S. Gaikwad²

^{1,2}Department of Electronics and Telecommunication Engineering

Sinhgad Institute of Technology, Lonavala

Email: sandip722@gmail.com¹, principal_sit@sinhgad.edu²

Abstract

Light measurement with accuracy is essential in creating desired outcomes in practical daily applications such as poultry industry, traffic lighting system, gardening or farming, at emergency exits, etc. Hence, light measurement and scrutiny is an important step to ensue the efficiency as well as safety. Normally the growth of plants depends on light intensity falls on top of canopy. In this paper we have presented the real-time remote Light intensity monitoring system using Raspberry Pi, which provides the facility to monitor the lighting system remotely. The main characteristic of the proposed system is timely light intensity monitoring and storage of data in the database on the cloud for further reference in future. Because of this facility it is easy to take proper decision at proper time to obtain the required result for the growth of plant.

Key Words: Green House, Light Intensity; Remote Monitoring; Raspberry Pi; a Web server; Wi-Fi; Dynamic Charts.

I. INTRODUCTION

There are many applications available to measuring and maintain the sufficient light levels such as laboratories, hospitals, educational institute, etc. To sustain healthier and safety environment enough light levels in the premises are needed. Without any distraction of whether condition, the light intensity has to be adequate for the growth of plant. Also in the summer season, intensity of light comes from the sun is

too high which has to be restricted to avoid overheating of the plants. It helps to maintain the health of plants.

The role greenhouse is to facilitate a structure for rising plants that is transparent to light; however it should be sufficiently enclosed to minimize the convective heat loss (i.e. the swap of air between inside and outside). Although some solar radiation travels through the covering material which results in high heat and some of it, is consumed by plant for photosynthesis, which helps to produce useful biomass. The light situation inside a greenhouse structure is primarily evaluated by the quantity of solar radiation established at the location as shown in the below figure. The beginning of electric lighting started the utilization of artificial light sources for irradiation. Artificial sources are like fluorescent, high-intensity discharge lamps which can be used to complement the (limited) quantity of solar radiation absorbed by a crop on darker days.

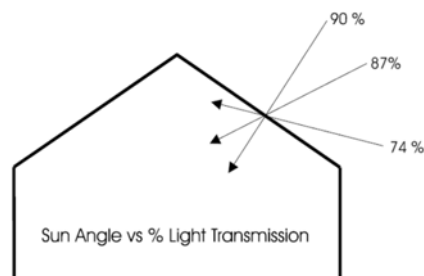

Fig. Solar Radiation Penetration in greenhouse

For that reason, a conversation on supplemental lighting should consider the special effects of

solar radiation to the light environment experienced by greenhouse plants. Also the greenhouse arrangement and a achievable shading system will minimize the quantity of solar radiation reaching on the top of plant canopy. The victorious use of supplemental light to greenhouse plant production needs a careful design incorporating fundamentals such as light intensity, light division and consistency, the rate of operation, and system preservation. When measuring light for the growth of plants, it is vital to use the proper unit of measurement respectively, the suitable type of sensor, and the beloved placement of light sensors. We can control not only the shading system but also the lighting environment in greenhouse with the help of Computer. However in some cases it needs carbon dioxide enrichment.

Once the solar radiation touches the earth surface, the greenhouse structure is the very first barrier it has to pass through. Framing members and glazing bars are normally dense and absorb or reflect completely the light falls on them. The same is in the case of gutters. Adding up, shade curtains, electric conduits, water lines, heating tools and pipes, horizontal airflow fans, and supplemental lightings are setup close to the top of greenhouse, which blocks the light from reaching to the plants inside. In several cases, evaporative cooling pads and drying fans are setup in the sidewalls, which later minimize the quantity of solar radiation. All added above, a very noteworthy quantity of solar radiation obtainable outside the greenhouse will never touch the plants inside. Especially during the darker months of the year when the solar elevation above the horizon is less and the days are small, the greenhouse structure and the various systems setup can block large quantity of light from reaching to the plants. As a final point, the preference of greenhouse cover (glass or plastic) will have an effect on the quantity of light transmitted.

II. PROPOSED WORK

The proposed work consists of greenhouse design considerations and electronic system development.

A. Green House Structure Consideration:

The greenhouse structure consists of automatic light intensity based electronic system employed inside beside with movable ceiling panels as indicated in Figure above.

B. Light Intensity Measurement

For the sake of light intensity based ceiling diaphragm control, LDR based light intensity measurement circuit is developed. The circuit design is as indicated in Figure below.

The designed circuit using op-amp IC TL072 is 3rd ordered low pass filter. The low pass filter allows passing frequencies below 100Hz. The low pass filter requires avoiding sudden sparkling from light sources. The output of this circuit is adequately calibrated to be fed to ADC circuit which includes MCP 3208. The calibration measurements are shown in equation 1 and 2.

The correlation between light intensity LUX and Load resistance RL for LDR is as bellow,

$$RL = (500/LUX) \text{ KOhm} \dots \dots \dots (1)$$

Hence the output voltage of LDR when given to 3.3V supply voltage via 3.3K resistor is given by,

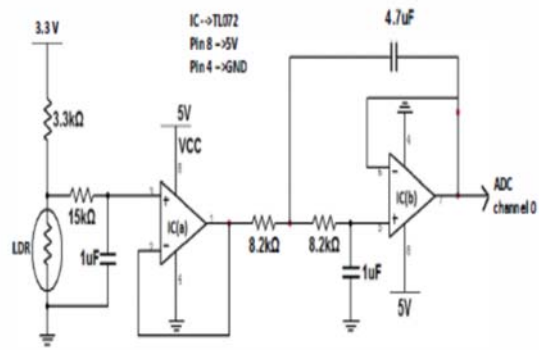

Fig. LDR based light intensity measurement circuit

$$V_0 = (3.3 * RL) / (RL + 3.3) \dots \dots \dots (2)$$

Hence, LUX can be calculated by,

$$LUX = ((1650/V_0) - 500) / 3.3 \dots \dots \dots (3)$$

C. Analog to Digital Converter (ADC)



Fig. MCP 3208 ADC.

MCP 3208 is 12bit ADC which acts as bridge among Raspberry pi and analog circuit. SPI interface is probable from MCP 3208 to Raspberry pi GPIO header [8].

D. Raspberry Pi Board

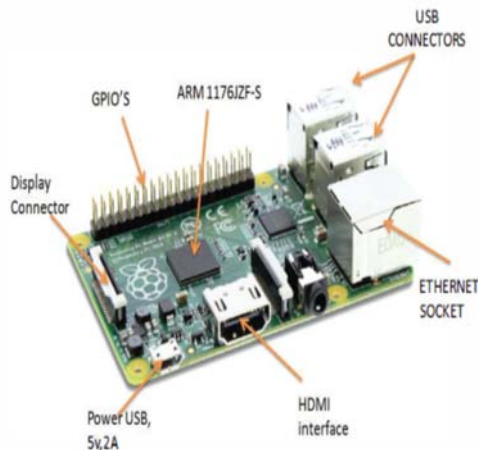

Fig. Raspberry Pi Board

Raspberry Pi is a PAN-card-sized ARM powered Linux computer manufactured in the UK by Raspberry Pi foundation with the purpose of inspiring the teaching of basic computer science in education institute. It has five models; Model A has 256Mb RAM, one USB port, but it has no network connection. Model B consists of 512Mb RAM, two USB ports, and an Ethernet port for connection.

E. WiFi Dongle

Wi-Fi is a widely used wireless networking technology therefore uses radio waves to supply wireless high-speed Internet and network services. The Wi-Fi coalition, the organization which owns the Wi-Fi registered trademark term principally define the Wi-Fi as any "wireless local area network (WLAN) products which is based on the Institute of Electrical and Electronics Engineers' (IEEE) 802.11 standards.



Fig. WiFi Dongle

III. SYSTEM DESIGN AND RESULTS

A. System Overview:

The complete platform is designed for the proposed work which is indicated in the block diagram in figure below.

The raspberry Pi board is attached with Humidity, Light measurement and control circuits. After collecting all data it uploads to Cloud based server by which the data is available to the user via a wireless internet connection to the cloud through smartphone or tablet. We can save or obtain in the database, developed web application saved in the server. The user can have access the system with IP address through computer, Smartphone or Tablet or any other internet accessible device.

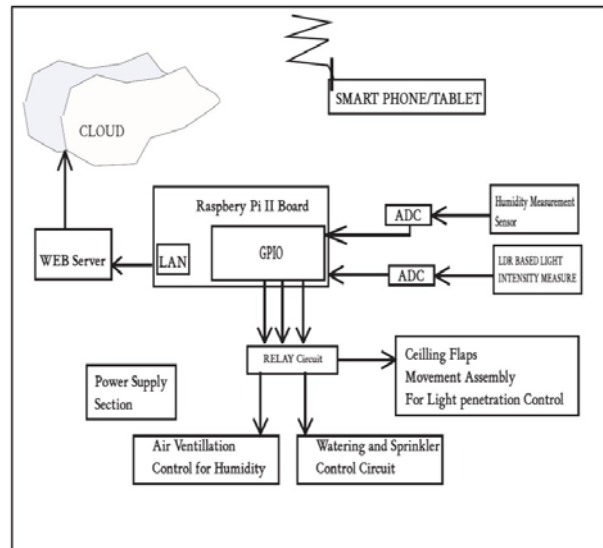

Fig. System Design Block Diagram

B. Crop Considerations:

Table 1 shows the light intensity based irradiances considered for diverse crops along with supplementary light sources with necessary duration in hours.

TABLE I. CROP-BASED IRRADIATION

Crops (Species)	Day Duration (Hours)	Irradiance (W/m2)
Tomatoes	12-15	8-15
Cucumber	11-13	8-15
Peppers	12-15	8-15
Foliage Plants	3-6	8-15
Bedding plants	3-8	3-9
Roses	11-12	5-8

For appropriate plant growth, the light intensity will be controlled as per the values indicated in table 1. which shows that the growth at the outcome is more superior in comparison with the normal greenhouses. Table 2 shows that the follow-on growth in the plants height from the

day of seeding i.e. from the very first day. The readings are considered only after the 1-month duration with projected controlled environment as in proposed platform.

TABLE II. COMPARATIVE PLANT GROWTH ANALYSIS

Crops (Species)	Growth due to existing system (in cm)	Growth due to proposed system (in cm)
Tomatoes	11-14	15-18
Cucumber	8-11	12-13
Peppers	9-11	12-14
Foliage Plants	11-12	16-17
Bedding plants	3-4	6-8
Roses	12-13	15-18

IV. CONCLUSION

The proposed platform of cloud based light intensity monitoring system for appropriate plant growth in greenhouse has revealed considerably enhanced the results in plant growth. The results are acceptable in terms of well-timed information gathering and appropriate monitoring the environment of the plant as per crop requirements. The marketable farming can get benefited in terms of fast and vigorous plant growth resulting in more earnings. For the sake of future extension in case of more enhancements, the data available in the cloud may be used as a platform for future policy and new strategies at any instant of time by smart terminals linked to the internet.

REFERENCES

[1] Tillmann De Graaf, Mennatalla Dessouky and Helmut F.O. Muller, "Sustainable

lighting of museum buildings", Science Direct journal volume 67, July 2014, pp. 30-34.

[2] Bezbradica M, Trpovski Z, "Advanced street light maintenance using GPS, the light intensity measuring and incremental cost-effectiveness ratio", International Conference on High-Performance Computing and Simulation, 2014, pp.670-675.

[3] Nagaraju, C. H. Kireet, N. Pradeep Kumar and Ravi Kumar Jatoth, "Performance Comparison of Signal Conditioning Circuits For Light Intensity Measurement", World Academics Journal of Engineering Sciences, PP. 2007 (1-10), Vol. 01, Issue 02, 2014 (ISSN: 2348-635X)

[4] W. Winchell, "Lighting For Poultry Housing" Agricultural Engineer, Canada Plan Service.

[5] N.R Mohantyand, C.Y Patil, "Wireless sensor and network design for greenhouse automation", International Journal of Engineering Technology, vol3, Issue2, August 2013.

[6] Anjum Awasthi & S.R.N Reddy of IP University, India, Global Journal of computer science and technology network "Monitoring for precision agriculture using WSN", web & security volume 13 issue 7 Version 1.0 Year 2013.

[7] Hong-Geun Kim, Chang-Sun Shin, Yong-Yun Cho, and Jang-Woo Park "A study on localization based Zigbee and Monitoring system in Greenhouse Environment" Proceedings of IEEE 3rd International Conference on Data Mining and Intelligent Information Technology Applications PP190-195 oct 2011. www1.microchip.com/downloads/en/DeviceDoc/2198c.pdf.