



TEST RIG DESIGN AND TESTING PERFORMANCE OF LINEAR BALL BEARING

¹Khandare Namdeo Ramchandra, ²Dr. Raghuvir Pai

^{1,2}Department of Mechanical & Manufacturing Engineering,
MIT Manipal, India

Abstract— over the past few years there have been advances in the improvement of bearings, in various engineering applications. In this paper experimental study has done to test the performance of linear ball bearings. These bearings are extensively used in automobiles, considering its application test rigs developed to carry out the endurance test and the hysteresis test of the linear ball bearing. These bearings are used to trim down the efforts of drivers in gear shifting mechanism. It is important that friction should be lesser in rolling element and selector rod as these bearings partially rotate and displace. This paper describes the test rig design and compares performance of the linear ball bearing under various significant parameters.

Keywords— (test rig, linear ball bearing, endurance, hysteresis)

INTRODUCTION

Now days the bearing behavior and performance analysis has been mainly based on few major aspects i.e. vibration analysis and endurance test. Each sample bearing is tested on the test rig regarding endurance test and vibration spectrum analysis under given operational spectrum analysis under given operational manner and from the test results most favorable bearing selection is made.

Bearing life is also assessed by the accelerated speed tests.

Anti friction bearings, while in operation, are subjected to damage, which lead to decline in material strength of the bearing or to weakening of the qualities of the bearing. Vibration signature analysis is used on the test rig to identify the state of bearings without dismantling it and their conditions are assessed in accordance with requirements of the operating conditions and to minimize the effect of the intervening elements on the final received signal, the transducer is kept directly on the bearing outer race in test rig. Provision is also made to monitor vibration signature from the bearing housing.

On the bearing test rig high frequency resonance technique, a highly sensitive and accurate procedure for easily identification of impending bearing failure can be used successfully. The technique can be used primarily for the smallest defect detection in the antifriction bearing [1]. The vibration monitoring method is employed to examine various faults in bearing and it also give away prior information in case of progressive defects[1].

The following defect can be identified in bearings [2]

- 1) Distributed defects
- 2) Localized defects

Distributed defects generally happen due to manufacturing faults, poor installation or mounting and abrasive wear [3]. Distributed defects comprises of surface roughness, waviness, misaligned races and irregular diameter of rolling elements [4] - [5]. The variation in contact force among roiling elements and raceways due to distributed defects create an increased level of vibration. Hence, the study of vibrations generated by distributed defects is mostly for quality inspection of bearings and for condition monitoring [6]. Localized defects consists of cracks, pits and spalls on rolling surfaces due to fatigue [7]. Localized defects speed up when the bearing is overloaded or subjected to shock (impact) loads during their functioning and also boost with the rotational speed [2]. Spalling can occur on the inner ring, outer ring, or rolling elements [2]

In automobiles especially in four wheelers driver requires more efforts in gear shifting mechanism. In recent years few technologies have come into the existence. Out of those linear bush ball bearing is considered as the economical as well as convenient. These machine elements are used to reduce the friction in the bearings which gives the ease to drivers while in shifting the gears [8]. In general these bearings are consists of balls cage and shell. The cage separates the group of balls in different rows and holds them within the inner and outer race. Inner race is shaft on which bearing is placed and it allows them to rotate freely. Bearings life is depend on the applied load and rpm. As these bearing are used in selector rods so it is difficult to lubricate. In this paper study has been done on the bearing without lubrications. The friction in a rolling bearing is depend on several factors I.e. magnitude and direction of load, speed and lubrication condition. Friction of any magnitude represents energy loss and causes retardation of motion [9].

Endurance testing refers to tests typically done to find out whether an application can bear up the processing load it is expected to have to endure for a long period. En- durance testing is a global employed technique to evaluate RCF of the bearing[10].In case of bearings to carry out the endurance test bearings are run to the L_{10} life in hours or in revolution and find out whether they can withstand for that specific load and rpm. Bearing endurance testing is

performed to set up life ratings, conduct quality auditing, and evaluate material, heat treatment, internal geometry, and surface finish improvements. Great variation can be expected despite the fact that bearings are run under identical condition.

2. EXPERIMENTAL TEST

After studying the different test rig arrangements available with the world leading bearing manufacturers few antifriction test rigs are developed.

1) Endurance test

Before designing the actual test rigs some layouts are drawn for linear, angular and combined endurance test rigs. Angular (fig.1), linear (fig.2) and combined (fig.3) Specialty of this test rig is that from one test rig we can convert into three test set ups with little changes.

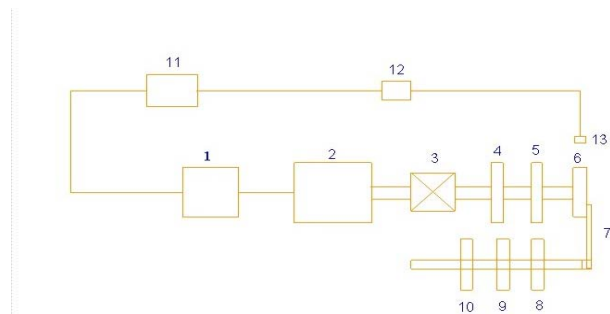

Fig.1 Angular test rig set up layout

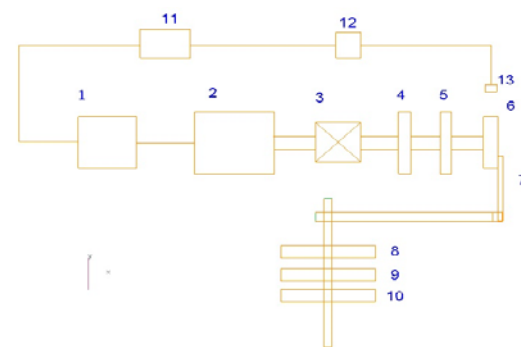

Fig .2 linear test rig set up layout

For Fig. 1&2

- 1-Drive
- 2-Motor
- 3-Coupling
- 4&5-Supporting ball bearing
- 6-T-Nut

- 7-mechanism
- 8&10-Supporting linear ball bearing
- 9-Test bearing (linear ball bearing) with accelerometer
- 11-Main supply
- 12-Digital counter
- 13-Sensor

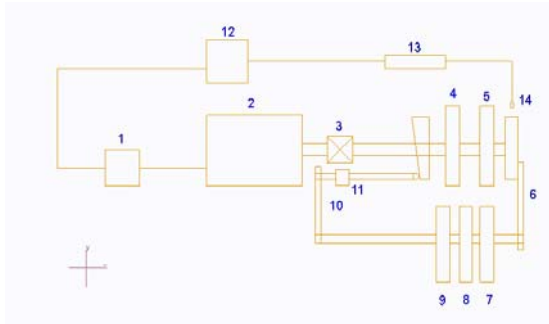

Fig.3 combine linear and angular test rig test set up

For Fig.3

- 1-Drive
- 2-Motor
- 3-Coupling
- 4&5-Supporting ball bearing
- 6-mechanism
- 7& 9-Supporting linear ball bearing
- 8-Test bearing (linear ball bearing) with accelerometer
- 10-link
- 11-Spring loaded cam and followe
- 12-Main supply
- 13-Digital counter
- 14-Sensor

RCF (rolling contact fatigue) life of bearings is relied on many factors such as bearing materials, material processing variables, lubricant system, elasto hydrodynamic (EHD) film thickness, contact stress levels and other environmental and operational effects [10]. The aim to carry out endurance tests on linear ball bearings, a laboratory test-rig has been designed and realized. The implemented test rigs as shown in Figure 4, 5 and 6 are composed by a 0.75 kW ac motor able to reach

a maximum rotational speed of 1300 rpm, speed control performed by means of drive. The motor is rigidly fixed. The rotating shaft, connected to the motor is supported by two bearings with single row deep groove ball bearing, lodged in two housing fixed on the external structure. End of the shaft. Four bar mechanism has been used to carry out the angular motion test. In the same test changing the position of four bar mechanism with the help of end rod linear motion has been achieved. Two support bearings are used to support the test bearing. The load has been applied on the test bearing. Proximity sensor has used to count the revolution of shaft (rpm).In the same set up with little alteration oscillation and displacement has been achieved. For achieving it spring loaded roller cam and follower mechanism is used.

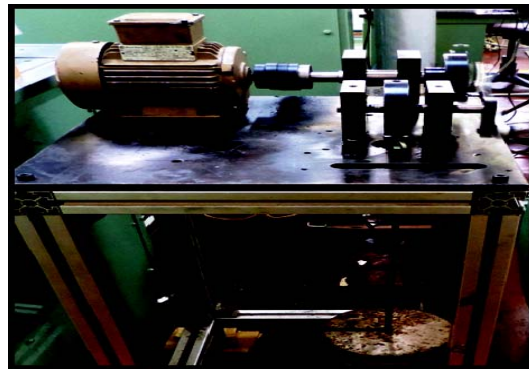

Fig.4. Endurance test set up for angular test

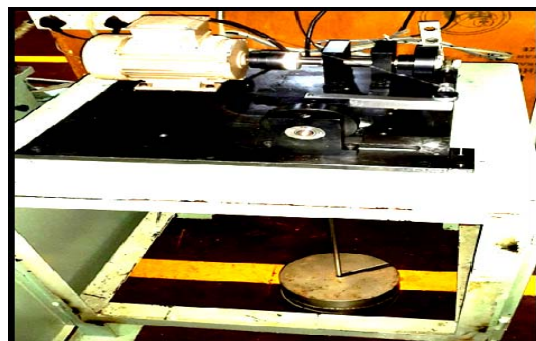

Fig.5. Endurance test set up for linear test

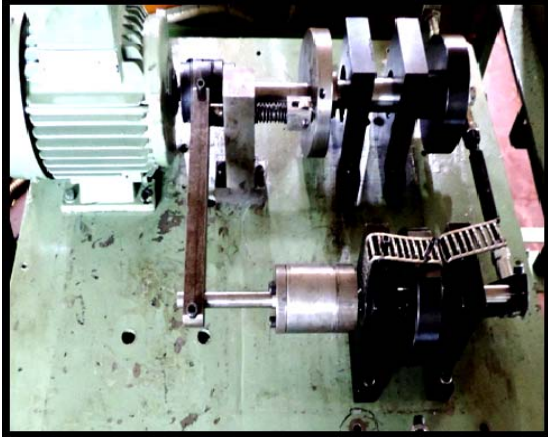

Fig.6. Endurance test set up for combined angular and linear

2) Hysteresis test set up

Hysteresis test set up has been developed to find the friction resistance of the linear ball bearing. In this set up displacement sensor has been used to find out the displacement of the shaft and force sensor is used to measure the force required for to and fro motion of the shaft in test bearing. For giving the motion to shaft scotch yoke mechanism has been used. This gives smooth motion to the shaft. Considering the application of the linear ball bearing speed of the shaft is maintained.



Fig.7. Hysteresis test set up

3. RESULT AND DISCUSSION

The average chemical composition (in wt %) of steel (from Spectra analysis) was found to be Fe: 95.91%, C: 1.12%, Mn: 0.43%, Si: 0.36%, Cr: 1.6%, S: 0.027%, P: 0.024%, Ni: 0.24%, Cu: 0.26%, Mo: 0.04%. It can be seen that the compositions are reasonably close to the

nominal composition of SAE 52100 steel [11]. Since the aim of the experimental campaign is the testing performance of linear ball bearing the first endurance test is performed with a light load. Then eventually load increased 100N, 150N, 200N and 250N load. After every endurance test, bearings visual and geometrical parameters checked.

In fig.8 it's described that in first case 50N load is applied and the set up is run for 120 rpm for 2.5 million revolutions. This test is carried out for all the three motions of bearing: linear, angular and combined (linear and angular) then the test bearing is removed from the test rig. And test bearings visual inspection (spalling, indentation marks, and cracks) and geometrical inspection (ID, OD, width of the bearing, cage, shell, ball and shaft) is done. No deformation was observed in the bearing and all the dimension were within the tolerance of the bearing so it is considered as 0% deformation. Fresh bearing is used for the new loads 100N, 150N, 200N and 250N and the test is carried out for 120 rpm. Each load bearing passed the test and no deformation observed. Bearing passed the endurance test for 120 rpm.

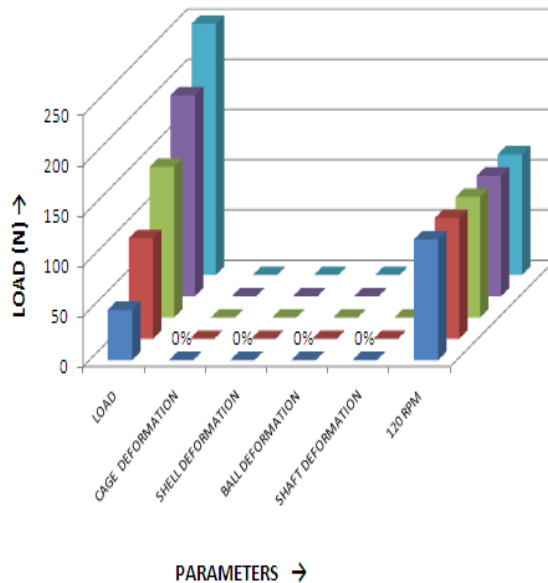

Fig.8 Endurance test for 120 rpm

In fig.9 it's described that in first case 50N load is applied and the test rig is run for 300 rpm and after completion of test, bearing is removed from the test rig. Test bearings visual inspection (spalling, indentation marks, and cracks) and geometrical inspection (ID, OD,

width of the bearing, cage, shell, ball and shaft) is done. No deformation was observed in the bearing parts and all the dimension were within the tolerance of the bearing. Fresh bearing is used for the new loads 100N, 150N, 200N and 250N and the same test is carried out for 300 rpm. Each load, bearing passed the test and no deformation observed. Bearing passed the endurance test for 300 rpm of linear angular and combined (linear and angular).

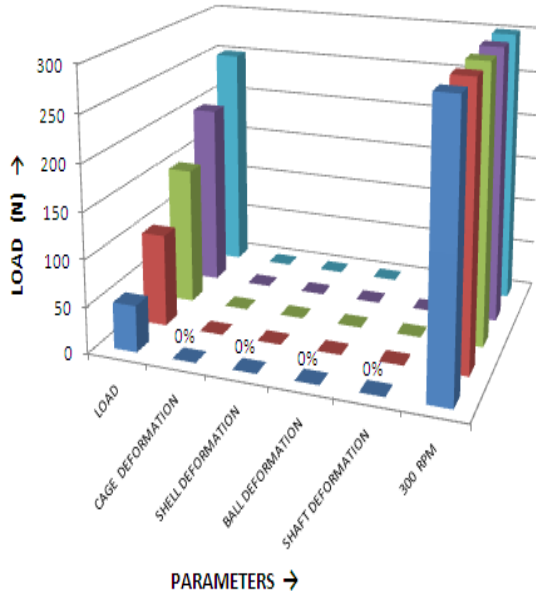

Fig.9 Endurance test for 300 rpm

In fig.10 it's described that in this case rpm is increased to 600 rpm. Initially 50N load is applied and the test rig is run for 600 rpm and after completion of test, the test bearing is removed from the test rig. Its visual inspection (spalling, indentation marks, and cracks) and geometrical inspection (ID, OD, width of the bearing, cage, shell, ball and shaft) is done. No deformation was observed in the bearing parts and all the dimension were within the tolerance of the bearing. Fresh bearing is used for the new loads 100N, 150N, 200N and 250N and the same test is carried out for 600 rpm for each load bearing passed the test and no deformation observed. In loading zone rubbing marks observed in combined test. Bearing passed the endurance test for 600 rpm

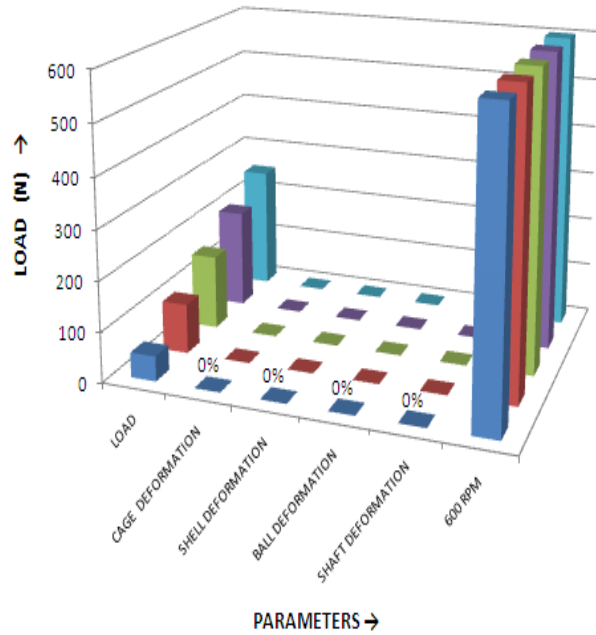

Fig.10 Endurance test for 600 rpm

Hysteresis test (Ref.Fig.11) is carried out for load 50N and 250 N for constant speed of 8 mm/s for cage stroke (mm). It requires less amount of friction force for displacement of shaft in case of 50N load as compare to that of 250N load.

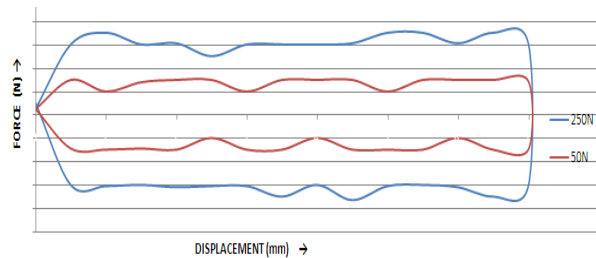

Fig.11 Hysteresis graph for 8 mm/s (exaggerated view)

In fig.12 speed of the set up increased to 14 mm/s for cage stroke and friction force required was less compare to friction force required for 8mm/s. The Friction force depends on the applied load, speed of shaft and the surface finish of the balls.

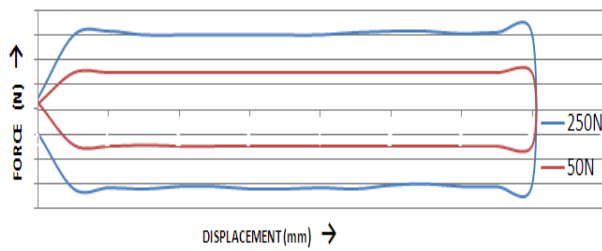

Fig.12 Hysteresis graph for 14 mm/s
(exaggerated view)

4. CONCLUSIONS

In this paper discussion of test rig design has been done. This paper describes the endurance test and hysteresis test for various load, rpm, and speed. This research is started because in real life application driver require more force while shifting the gears, in this paper various loads has been used to check the endurance life of the bearings for 2.5 million revolutions. Considering the exact application in automobile same motions given to the bearings and test successfully passed for load 50N, 100N, 150N, 200N and 250N and rpm 120 rpm, 300 rpm and 600 rpm. In hysteresis test bearing speed is varied from 8mm/s to 14 mm/s for low speed friction was more, compare to high speed. As speed increased friction force reduced. In this test it's observed that for low load friction force required was less compare to high load. And for high speed friction force was low compare to low speed.

5. REFERENCES

- [01] M. Amarnath, R Shrinidhi, A.Ramachandra and S.B. Kandagal,(2004)“Prediction of defects in antifriction bearings using vibration signal analysis”, Journal of IEI, Vol. 85, pp 88-92.
- [02] S Patidar and P Kumar Soni (2013) “an Overview on Vibration Analysis Techniques for the Diagnosis of Rolling Element Bearing Faults” International Journal of Engineering Trends and Technology (IJETT) - Volume 4 Issue5 pp 1807-1809
- [03] C.S.Sunnersjo, ‘Rolling bearing vibrations - geometrical imperfections and wear’ Journal of Sound and Vibration’ Vol. 98, No. 4, pp. 455-74, 1985.
- [04] N.Tandon and A. Choudhury, ‘A theoretical model to predict vibration response of rolling bearings to distributed defects under radial load’ Journal of Vibrations and Acoustics, Vol. 120, pp. 214-20, 1998.
- [05] T.E. Tallian and O.G. Gustafsson, ‘Progress in rolling bearing vibration research and control’ ASLE Trans., Vol. 8, No. 3, pp. 195-207, 1965.
- [06] S. Braun and B. Danter, ‘Analysis of Roller/Ball Bearing Vibration’ ASME-Journal of Mechanical Design, Vol. 101, pp 118-125, 1979
- [07] Y. Li and C. Zhang, ‘Dynamic Prognostic Prediction of Defect Propagation on Rolling Element Bearing’ Journal of Vibration and Acoustics, Trans of ASME, vol. 85, no. 1, pp: 214- 220. July 2004.
- [08] M Nunney "Light and Heavy Vehicle Technology" Elsevier ltd, Edition 2007 303-307, ISBN: 0750638273
- [09] T A Harris “Rolling Bearing Analysis “John Wiley & Sons, Edition 1966, 421-422 ISBN:
- [10] J. J. C. Hoo, “Rolling Contact Fatigue Testing of Bearings Steels,” ASTM Special Technical Publication, Philadelphia, 1981, pp. 169-189.
- [11] H. K. D. H. Bhadeshia, “Steels for Bearings,” Progress in materials Science, Vol. 57, No. 2, 2012, pp. 268-435