



MOTION ANALYSIS OF ARTICULATED ROBOTIC ARM FOR INDUSTRIAL APPLICATION

Pradeep Kumar Dhote¹, J. C. Mohanta², Mohd. Nayab Zafar³

Department of Mechanical engineering, MNNIT Allahabad

¹PG Scholar, ²Assistant Professor, ³Research Scholar

E-Mail:p.dhote1992@gmail.com¹,jcmohanta@mnnit.ac.in², nayab.zafar7@gmail.com³

Abstract

This paper presents the analysis of stresses and deformation induced for a particular payload of a robot. An articulated type industrial robotic arm has been considered for motion analysis. The modelling of articulated robotic hand has been created by 3D software SOLIDWORKS and the analysis have been performed by using ANSYS R15 software. In order to compensate the work the kinematic analysis also performed in a 2-D scale through computer simulation. This shows the 2D plot for the different combinations of joint angle within its work envelope. The forward and inverse kinematics analysis has been used to co-relate the desired location and orientation of end effector with joint variables. MATLAB simulation result has been compared with the theoretical analysis for various link positions and it has been found that both the results are in phase and have good agreement with each other.

Index Term: Articulated Robot, Forward and Inverse kinematics, Payload, Workspace.

I. INTRODUCTION

Robots that are used in industries having several human like characteristics. This robot includes mechanical arms similar to human hand used for various industry tasks. Such anthropomorphic or human like characteristics include some sensory devices those are used to communicate and interact the machine with other machines to take

simple or important decisions to operate efficiently [3].

An industrial robot consists of a mechanical manipulator and a controller to move it and perform other related functions.

- The mechanical manipulator consists of joints and links to position and orient the end of the manipulator relative to its base
- The controller operates the joints based on co-ordinate axis to perform a programmed work cycle
- A robot joint is similar to a human body joint. It provides relative movement between two parts of the body.

Industrial robots work on the same principle like numerical control machine which follows the developed path, and the history is related. Both are assigned with dedicated central computers to operate controlling devices [5]. However, Robots can perform a variety of tasks as compare to numeric control machines.

II. Modelling of Robot

The model of the articulated robotic joint has been created by using software SOLID WORKS. The complete model has been assembled by using the various parts of the robot. The assembly includes parts such as base, body, upper arm, fore arm, end gripper etc. To provide relative motion between these parts a cylindrical type pin has been used. Each and every part of the model having different dimensions. The model specification has been shown in the table

I. For complete modelling used software SOLID WORKS contains four important sections which is manual drawing, part module, assembly module and drawing module shown [1]. First two sections provide the model and design parts of the robot to user. The assembly module enables the parts to be modelled in the assembly which provides the relative motion between the parts by using the revolute joints through cylindrical pin. The final section is drawing module that creates the drawing of the created parts in different formats.

For design analysis the model is being analysed in three different cases. This case study refers to the different joint angle.

I. Specification of Model

II.

Specification	Value
Number of axes	4
Horizontal Reach	300mm
Vertical Reach	450mm
Drives	4 servo motors
Configuration	a)All axes completely Independent b)All axes can be controlled simultaneously
Work envelope	a)Shoulder rotation b)Elbow rotation c)Gripper rotation
Material	Structural steel Density- 7800 kg/m. ³ Poisson's Ratio – 0.3

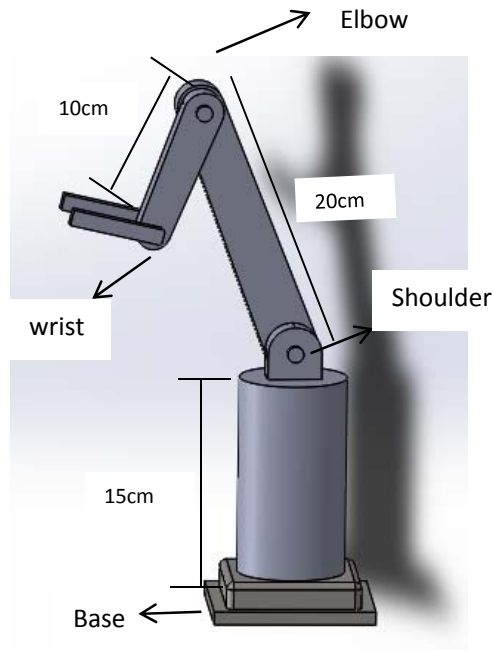

Fig. 2.1: Assembled model

III. Mathematical Calculation

A) Force and Moment calculation

The load which is to be lifted by the robot provide its effect on every part of the model, its effect should be analysed on each joint in terms of moment provided by load lifted and weight of the motor which gives the direct loading on the joints[2]. Direct force and moment calculation gives the result in terms of stress and the deformation of the part. To calculate the parameters under consideration are as follows:

- I. weight of each linkage
- II. weight of each joint
- III. weight of object to lift
- IV. length of each linkage

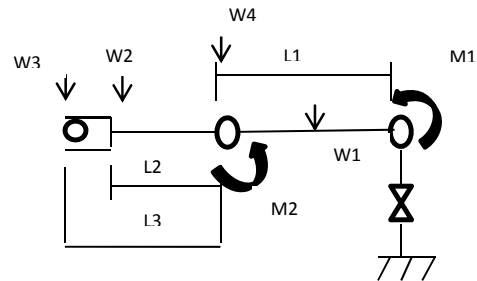

Fig 3.1: Force and moment calculation

Torque About Joint 1:
 $M1 = L1/2 * W1 + L1 * W4 + (L1 + L2/2) * W2 + (L1 + L3) * W3$
 Torque About Joint 2:

$$M2 = L2/2 * W2 + L3 * W3$$

B) Stress and deformation calculation

To find out the analytical solution the main assumption is that the loading condition makes the arm like a beam is in bending. Hence, by using bending equation

Stress value can be find out by- $\sigma = \frac{My}{I}$

Maximum deformation is given by –

$$\delta_{max} = \frac{Pl^3}{3EI} \text{ and } \delta_{max} = \frac{Ml^2}{2EI}$$

C) Kinematic analysis of Robot

Forward Kinematics

It involves the computation of position and orientation of the end effector, while knowing the joint angle and link length. The forward kinematics of the end-effector with respect to the base frame is determined by multiplying all of the ${}^{i-1}_i T$ matrices

$${}_{end_effector}^{base} T = {}^0_1 T {}^1_2 T \dots \dots \dots {}^{n-1}_n T$$

An alternative representation of ${}_{end_effector}^{base} T$ can be written as

$${}_{end_effector}^{base} T = \begin{bmatrix} r_{11} & r_{12} & r_{13} & p_x \\ r_{21} & r_{22} & r_{23} & p_y \\ r_{31} & r_{32} & r_{33} & p_z \\ 0 & 0 & 0 & 1 \end{bmatrix}$$

Inverse Kinematics

It involves the calculation of joint angle and link parameters for the desired position and orientation of the end effector.

To find the inverse kinematics solution for the first joint (q_1) as a function of the known elements of ${}_{end_effector}^{base} T$, the link transformation inverses are premultiplied as follows

$$[{}^0_1 T (q_1)]^{-1} {}^0_6 T = {}^1_2 T (q_2) {}^2_3 T (q_3) {}^3_4 T (q_4) {}^4_5 T (q_5) {}^5_6 T (q_6)$$

To find the other variables, the following equations are obtained as a similar manner.

$$[{}^0_1 T (q_1) {}^1_2 T (q_2) {}^2_3 T (q_3) {}^3_4 T (q_4) {}^4_5 T (q_5)]^{-1} {}^0_6 T = {}^5_6 T (q_6)$$

IV. Result and discussion

To analyse the design the structural analysis has been performed by using software ANSYS R15.0. The result shown as snap shot from the ANSYS for every part in all the three different case. The result obtained is then compared with the analytical result that is obtained by using the basic formulas of the strength of material. The result is calculated for lifting a load of say 10N, on comparing the result from both the process is tabulated and the % error obtained is not more than 5% for any part hence it is accepted.

A) To calculate maximum payload of robot

The above result shown is calculated for carrying a load of 10N and for this the robot is safe. Hence to calculate the maximum load for which the robot will not fail gives the maximum load carrying capacity of robot in other terms it is also called as the payload of the robot. By varying the load from 10-60N the robot will not fail for any cases.

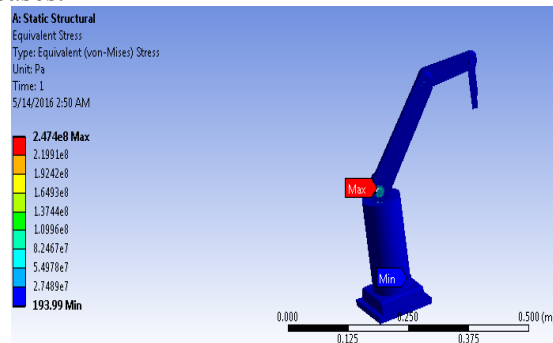

Fig. 4.1 Stress distribution for max. Payload (Case-3)

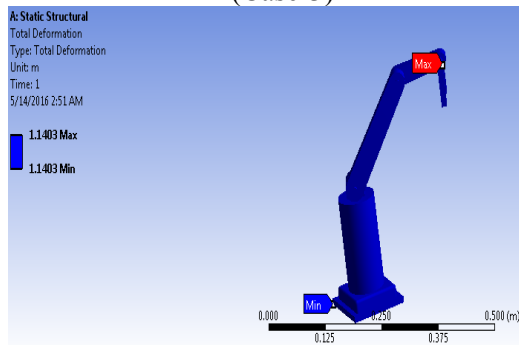

Fig. 4.2 Deformation for maximum payload (Case-3)

- Maximum stress generated for case-3 i.e. approx. 247MPa for the load of 60N
- For structural steel - A36 steel plate
 Yield strength- 250MPa
 Ultimate tensile strength - 400-550MPa

So, while designing the robotic arm the load should be less than 60N calculated at maximum speed based upon yield strength criteria for robot. Hence from the above result the model is best suited for Lifting a load of 50N.

The payload of robot at normal speed calculated as 50N.

B) Results of Kinematic Analysis

Inverse Kinematic modelling of Robotic Arm

Analysis is done for two link, 2 dimensional arm mechanism. For this simple mechanism the angle reducing for each joint will be as per the desired location of the tip of the end arm.

Let θ_1 be the angle between the first arm and the ground. Let θ_2 be the angle between the first and second arm. Let the length of first arm is L_1 and that of second arm is L_2 . Assume the limited rotation of arm hence, $0 \leq \theta_1 \leq \pi/2$ and $0 \leq \theta_2 \leq \pi$

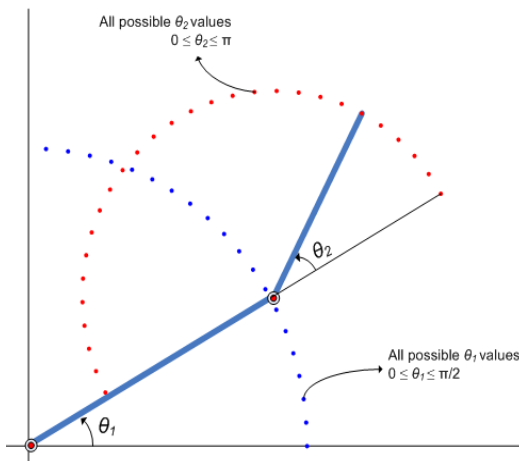

Fig.4.3 All possible joint values of θ_1 and θ_2

The plot shows the generated X-Y data point for different combination of θ_1 and θ_2 and reducing x and y co-ordinate for each joint. The plot has been generated by using the forward kinematics

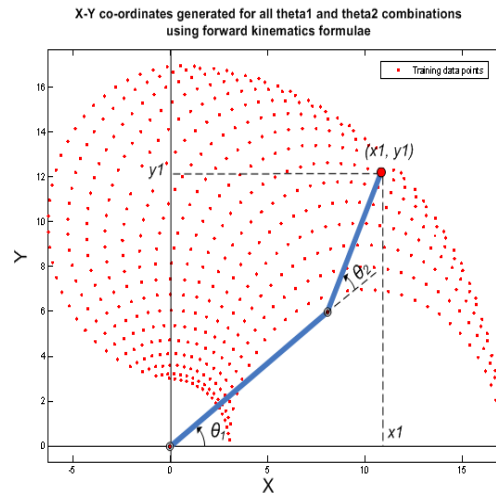

Fig.4.4 X-Y coordinate generated for all θ_1 and θ_2 combinations using forward kinematics formulae

Formula. Since the forward kinematics formulae for two joint robotic arms are known, X and Y co-ordinates of the tip of the arm can be calculated by moving it to desired range of angle rotation.

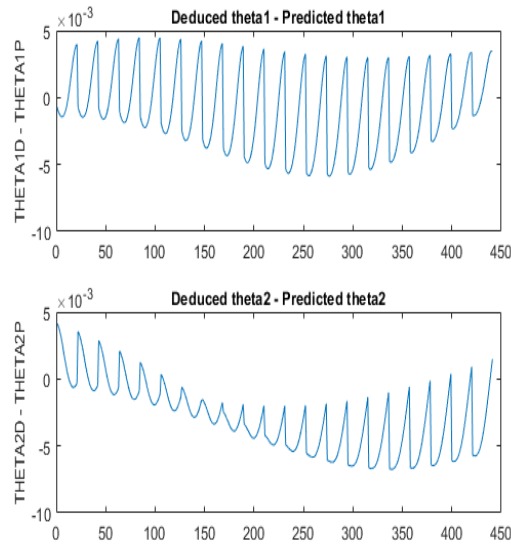

Fig.4.5 Variation between actual and predicted theta values.

THETA1D and THETA2D are the variables that hold the values of θ_1 and θ_2 reduced using the inverse kinematics formulae. The errors are in the range of $1e^{-3}$ which is a fairly good number for the different application.

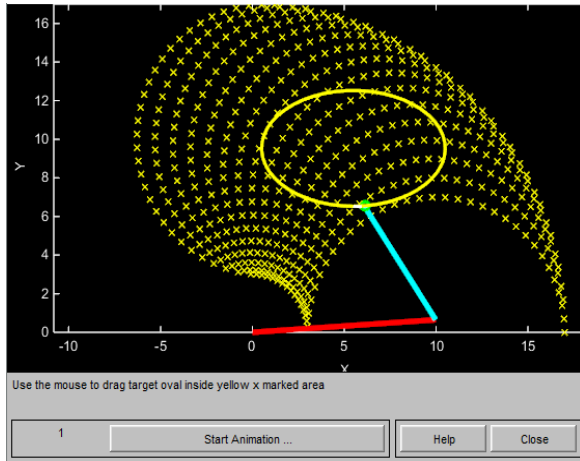

Fig.4.6 GUI for inverse kinematics modelling

GUI shows the inverse kinematic modelling for the mechanism. The command used is *invkine*, this shows the tip is tracing an ellipse. By moving it within the range of Co-ordinate workspace it will verify the result.

V. Conclusions

After getting results the paper can be concluded to its result in a way that, the work is completely based on theoretical approach to follow certain design criteria. To avoid failure of parts the stress value find should be lower than the yield point limit for the material. Maximum stress (Von Misses Theory) criteria used to define the payload of the robots. On the basis of payload the robots can be used for different applications. At maximum payload the robots will not follow the predefined path hence normal payload is always used for the robots. As from the result obtained the normal payload of the robot is 50N which the model can lift within the yield stress limit of the material.

In the second part, motion planning result containing graph which shows the error between the predicted angle variations with the actual variation of the angle. This type of error is found because of the joint constraints of the robotic manipulator. The estimated errors are in the range of $1e^{-3}$ which is fairly good number and can be used for the applications where the very high accuracy is not desired.

VI. REFERENCES

[1] Rosidah Sam, Kamarul Arrifin, Norlida Buniyamin, "Simulation of pick and place robotics system using solidworks softmotion," International Conference on System Engineering and Technology, September 11-12, 2012.
 [2] B.O.Omijeh, R.Uhunmwangho, M.Ehikhamenle, "Design Analysis of a Remote

Controlled Pick and Place Robotic Vehicle," International Journal of Engineering Research and Development Volume 10, Issue 5 (May 2014), PP.57-68 .

[3] Ravikumar Mourya, Amit Shelke, Sourabh Satpute, Sushant Kakade, Manoj Botre, "Design and implementation of pick and place robotic arm," International Journal of recent research in civil and mechanical engineering, Vol. 2, Issue 1 (2015), pp:(232-240).

[4] Songliang Nie, Yuwen Li, Guo Shuai, Song Tao, FengFeng Xi, "Modeling and simulation for fatigue life analysis of robots with flexible joints under percussive impact forces," Robotics and Computer-Integrated Manufacturing 37 (2016) 292–301.

[5] K.Kiran Kumar, Dr. P.R.Thyla, "Singularity and workspace analysis of RRP serial Manipulator," International conference on recent advances in mechanical engineering, ICRAME 2010.

[6] Prashant Badoni, "Direct Kinematic modeling of 6R Robot using Robotics Toolbox," International Journal of Engineering research and application, ISSN: 2248-9622, Vol. 6 Issue 1, part-3(January 2016) pp 151-154.

[7] Serdar Kucuk, Zafer Bingul, "Inverse kinematic solution for industrial Robot manipulator with offset wrists," Applied Mathematical Modelling 38 (2014) 1983–1999.

[8] Nicolae Plitea, Dorin Lese, Doina Pislă, Calin Vaida, "Structural design and kinematics of a new parallel reconfigurable robot," Robotics and Computer-Integrated Manufacturing 29 (2013) 219–235.

[9] Hazim Nasir Ghafil, Ali Hussein Mohammed, Nabil H. Hadi, "A Virtual Reality Environment for 5-DOF Robot Manipulator based on XNA Framework," International Journal of Computer Applications (0975 – 8887) Volume 113 – No. 3, March 2015.

[10] Tahseen Fadhil Abbas, "Kinematics Modeling of 5DOFstationary Articulated Robots ", Eng. &Tech. Journal, Vol.31, No.3, university of Technology, 2013.