



DESIGNING AND MANUFACTURING OF CONTINUOUSLY VARIABLE TRANSMISSION (CVT)

Bansi Dalsania¹, Kishan Patel², Viren Gabani³, Ath S Singhal⁴, Vivek Dani⁵

¹Former student, Mechanical Engineering Department, Nirma University, Gujarat, India.

²Mechanical Engineering Department, Nirma University, Gujarat, India.

³Corresponding Author, Former Student, Mechanical Engineering Department, Nirma University.
Email : vivekdani.nit@gmail.com⁵

Abstract

The project aims at designing and manufacturing the Continuously Varying Transmission (CVT). The CVT is designed considering the requirements of SAE BAJA event and the engine used in the event i.e. B&S 10 hp engine. This gearbox provides better acceleration and ease in handling as compared to the manual transmission and cost effective as compared to the other transmissions available in the market.

I - Introduction

With growing demand for environment friendly technologies, automobile manufacturers today are increasingly focusing on 'Continuously Variable Transmissions' (CVTs) as an alternative to conventional gearbox transmission; to achieve a balance between fuel economy and vehicle performance. By allowing for a continuous band of gear ratios between the driver shaft and driven shaft, a CVT permits the engine to operate for the most part in a region of high combustion efficiency resulting in lower emissions, and higher fuel economy.

A continuously variable transmission (CVT) is a transmission which can gradually shift to any effective gear ratios between a set upper and lower limit. In contrast, most transmissions equipped on production cars have only 4-6 specific gear ratios that can be selected. The almost infinite variability of a CVT allows the engine to maintain a constant speed while the vehicle increases in velocity. This can result in better vehicle performance if the CVT is shifted such that the engine is held at the RPM that it

runs most efficiently at and/or produces the most power.

Because there are no steps between effective gear ratios, CVTs operate smoothly with no sudden jerks commonly experienced in manual transmission. Since drivers expect a car to jerk or the engine sound to change as they press the accelerator pedal further, it is very confusing for them when the car smoothly accelerates without the engine revving faster. Drivers have unfortunately perceived this as the car lacking power which is causing a marketing problem for the transmissions. [1]

II – Various Components of CVT

Mainly the CVT has Primary and Secondary clutches which are connected by belt in which the primary clutch is connected with engine and the secondary clutch to the gear box and the power is transmitted from primary to the secondary clutch by Belt. Following are the components used in the CVT,

- Primary Clutch
 - Fix Pulley
 - Movable Pulley
 - Spider
 - Cam
 - Follower
 - Primary Spring
- Secondary Clutch
 - Pulleys
 - Secondary Spring
 - Spring Retainer Plate
- Belt [2]

III -Functions of Various Components

As CVT is different than the conventional transmission system, components used in the CVT has some definite functions to do and for the same the design of that components varies from the conventional design of such components like for pulleys, cam, belt etc.

1) Primary and Secondary Clutches Function

Primary and secondary clutches are made of pulleys. To have the required performance of the vehicle the speed of the engine has to be reduced in the CVT, this variation in the speed reduction can be achieved by changing the contact diameters of the belt on pulleys. In normal pulleys the diameter cannot be changed so to have change in the contact diameter between belt and pulley, the pulley used are different from the conventional pulleys.

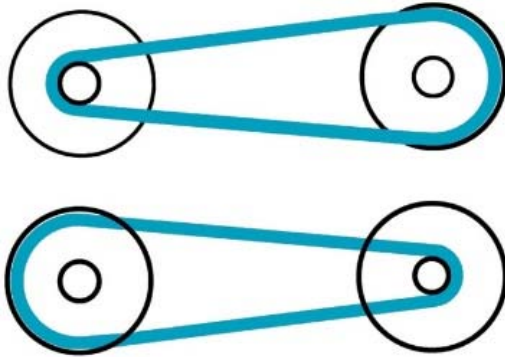

Fig. 1. Variation of speed ratio in belt driven CVT

Fig. 1. shows how the variation of speed ratio can be achieved in CVT. At starting when the speed of the engine is minimum the belt is at minimum diameter in primary clutch and at maximum diameter in secondary clutch so have maximum speed reduction, which is shown in Fig. 1. by minimum position. Now when the speed of engine increased due to throttling the belt shifts in clutches such that have contact at maximum diameter in primary clutch and minimum diameter in secondary clutch so have minimum speed reduction, which is shown in Fig. 1. by maximum position.

2) Function of Pulley

Pulleys are the main components of the CVT. There is basically two types of pulleys are used in CVT, one is fixed pulley and second one is movable pulley in both primary and secondary

clutches. The primary function of pulleys is to transfer power from input shaft to output shaft by means of belt. These pulleys are differing from conventional pulleys in terms of variable distance between two contact surfaces. [2]

2.1) Function of Fixed Pulley

Fixed pulley is used in both primary and secondary clutches, and it cannot slide on the shaft. The main function of the fixed pulley is to give support to the belt and to the secondary pulley. It has internal splines which meshes with the splines on the shaft and thus transmits the power and motion to the belt.

2.2) Function of Movable Pulley

Movable pulley is also used in both primary as well as secondary clutches. The main function of this pulley is to change the contact diameter of the belt on the pulleys, means to change the speed ratio. The pulley can slide on the shaft, thus the distance between the pulleys can vary and due to this the belt will move up or down due to wedge action. The primary clutch movable pulley moves on the shaft due to cam, which works on centrifugal force and came back to its original position by means of primary spring. While in secondary clutch the movable pulley will move due to belt tension generated by the primary pulley movement and it came back to original position by means of secondary spring. Which is shown in the Fig. 2. below. [2]

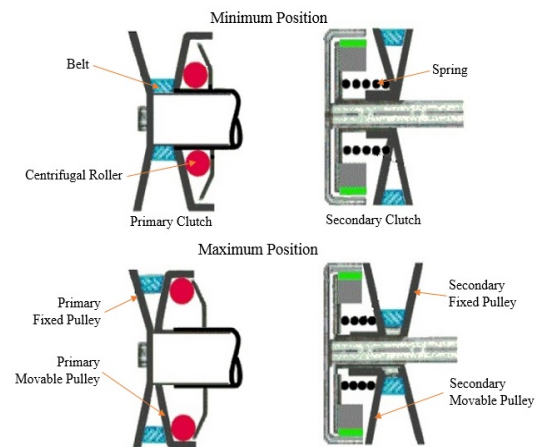

Fig. 2. Fixed and Movable pulleys

3) Function of Spider

Spider is used in the primary clutch. Its function is to support the cam and keep the cam in correct position. It keeps the cam aligned with the

movable pulleys during the rotation of the clutch. Spider is fixed on the shaft so when the cam moves due to centrifugal force it actuates the movable pulley rather than moving itself.

4) Function of Cam and Follower

Function of cam is to actuate the primary clutch movable pulley. This is done by the centrifugal force. Means due to centrifugal force the cam moves apart and actuates the movable pulley, which shifts the belt outward and increase the contact diameter of belt on the pulley. Fig. 3. shows the cam shape used in the CVT.

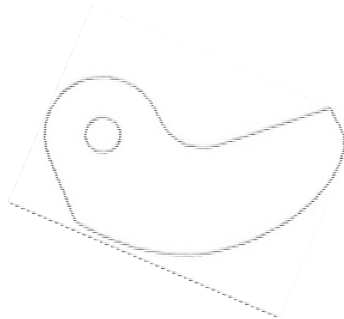

Fig. 3. Cam

Follower used in the CVT is of cylindrical shape. Which is mounted on the movable pulley. Three cam and follower are used and followers are aligned with the cam and spaced 120° apart.

5) Function of Springs

Springs are used in primary and secondary clutches. Function of springs are to return the movable pulleys to its original position when the speed of engine is reduced. Secondary spring has more importance than the primary spring, because secondary spring moves the secondary movable pulley return back to its original position and then due to belt tension the primary pulley also return back to its original position.

6) Function of Belt

Function of belt is to transmit the power from input primary clutch to the output secondary clutch. The power is transmitted by friction between belt and pulleys. Generally rubber belts are used for lower capacity CVTs and for higher capacity CVTs metal belts are used. Normal V rubber belts cannot be used as they are not capable to withstand the higher tension and the squeezing forces generated by pulleys to shift the belt, so special variable speed rubber belts are developed. For high torque transmission metal belts are used. [1]



Fig. 4. Rubber belt & Metal V-belt

IV - Designing of Continuously Variable Transmission

Pulley bases CVT is selected over other type of CVT, due to easy of manufacturing and its low cost. Continuously Variable Transmission (CVT) design is divided into number of steps,

- Engine selection and its performance
- Pulley and Belt design
- Variator design

Among all type of CVT most common CVT is belt and pulley type CVT. In this type of CVT there are so many variations, like CVT having metal belts, rubber belts and having variation in the actuating mechanism for the pulley like roller based, cam based, hydraulically operated, electrically operated etc. In this chapter the CVT having rubber belt and cam actuator is discussed. [3]

The CVT is design to use it in SAE BAJA competition vehicle, so the design parameters for the CVT are based on the rules and regulation of the competition and the specification of the BAJA vehicle. The vehicle performance considered for designing the CVT is as under. The maximum velocity required as 70 kmph and gradeability as 35° and assuming the weight of car as 400 kg and the tyre diameter as 22" (0.5588m). And it is assumed as the car has differential having gear reduction of 4.125.

1) Engine Parameter

For design of the CVT the engine selected is Briggs and Stratton "INTEK OHV 305 10HP (2044 Standard 2054 I/C) Engine". This engine is generally used in every SAE BAJA competition. Power output and torque output of engine at various engine RPM as shown in the Fig. 5. and in Fig. 6.

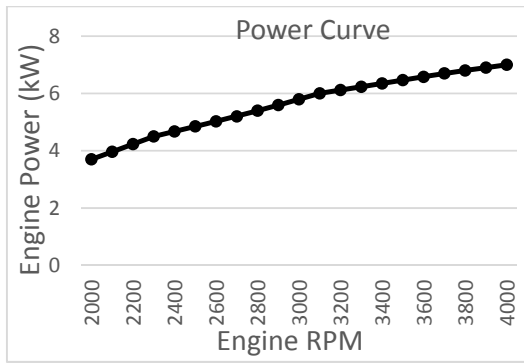

Fig. 5. Engine Power Curve

Fig. 5. shows that the maximum power is 7 kW at 4000 RPM and from figure 3.2 maximum torque is 18.6 Nm at 2600 RPM. But the maximum speed of engine is set to 3600 RPM using governor setting for smooth running and safety. The idling speed of engine is 1600 RPM. So the maximum velocity of the vehicle is calculated at 3600 RPM and the maximum acceleration and gradeability is calculated at 2600 RPM.

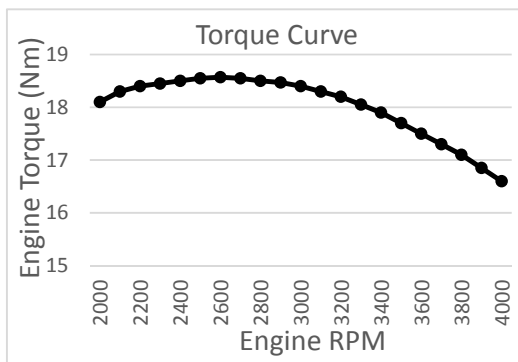

Fig. 6. Engine Torque Curve

2) Speed Ratio for CVT

First of all the maximum and the minimum speed reduction required to have the desired performance of car is calculated. Which can be calculated as shown below.

For a vehicle to have maximum speed of 70 kmph the required rpm of the wheel having 22" (0.5588m) tyre diameter can be calculated as, Maximum speed of car (v) = 70 kmph = 19.44 m/s

Tyre diameter (d) = 22 inches = 0.5588 m

Tyre RPM for max speed (N) =

$$\frac{v \cdot 60}{\pi d} = \frac{19.44 \cdot 60}{\pi \cdot 0.5588} = 664.41 \text{ rpm}$$

But the maximum rpm of the engine is 3600 rpm and in the drive train the differential is also used so the speed reduction required in the CVT can be calculated as,

Engine RPM (n) = 3600 rpm

Differential Gear Ratio (GR_{diff}) = 4.125

Tyre RPM for max speed (N) = 664.41 rpm

Speed reduction required =

$$\frac{n}{N \cdot \text{GR}_{\text{diff}}} = \frac{3600}{664.41 \cdot 4.125} = 1.31$$

So the minimum gear reduction required to have maximum speed of 70 kmph is 1.31 in the CVT.

Now to have the gradeability as 35 and enough the starting torque the required torque can be calculated as,

Mass of Car (M) = 400 kg

Gradeability (θ) = 35 °

Rolling Friction coefficient (μ) = 0.05

Torque required at Wheel (Mt) =

$$\begin{aligned} [M \cdot g \cdot (\sin\theta + \mu)] \cdot r &= \\ [400 \cdot 9.81 \cdot (\sin 35 + 0.05)] \cdot 0.2794 &= \\ &= 683.66 \text{ Nm} \end{aligned}$$

But the engine can produce the maximum torque of 19 Nm at the speed of 2600 rpm so the required speed reduction can be found as,

Max Torque of Engine (T) = 19 Nm @ 2600 rpm

Speed reduction required =

$$\frac{M_t}{T \cdot 2 \cdot \text{GR}_{\text{diff}}} = \frac{683.66}{19 \cdot 2 \cdot 4.125} = 4.36$$

So to have the required gradeability and smooth starting of the vehicle the required maximum speed reduction is 4.36.

Thus the CVT speed reduction ratio varies from 1.31 to 4.36 to have the required performance described above, which can be obtained by changing the contact diameters of belt on pulleys in the primary and secondary clutches.

3) Speed Ratio Distribution

In CVT the velocity of vehicle changes automatically with change in the speed of engine. So to have different speed of vehicle at different speed of engine the speed ratio of the CVT also varies with the engine speed from maximum to minimum.

At the initial stage of design the variation of speed ratio with the engine speed is assumed having linear variation. Assuming linear variation of the speed ratio vehicle velocity and acceleration is calculated, which are as shown in Fig. 7. Fig. 8. and Fig. 9.

As shown in Fig. 8. the velocity variation of vehicle is at the end of engine's maximum RPM and in Fig. 9. the acceleration is almost linear, which are not recommended for a vehicle. As well as for this type of variation of the speed ratio the belt length obtained is not constant, this is not possible to transmit the power at different speeds. So the speed ratio variation is selected in such a way that the velocity variation is linear

and the belt length is constant for all speed ratios. Which are shown in Fig. 10. Fig. 11 and Fig. 12.

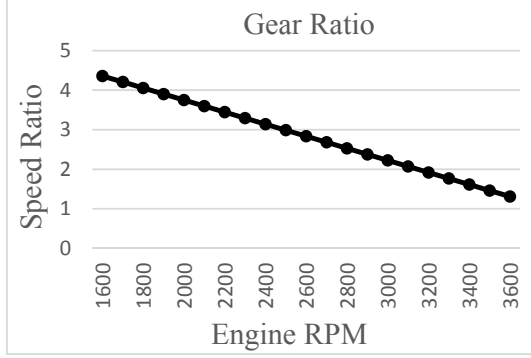

Fig. 7. Linear Variation of Speed Ratio

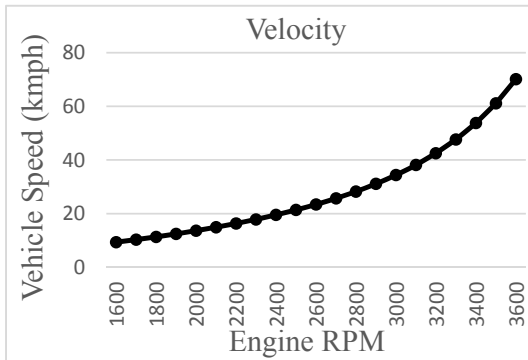

Fig. 8. Vehicle Velocity Having Linear Variation of Speed Ratio

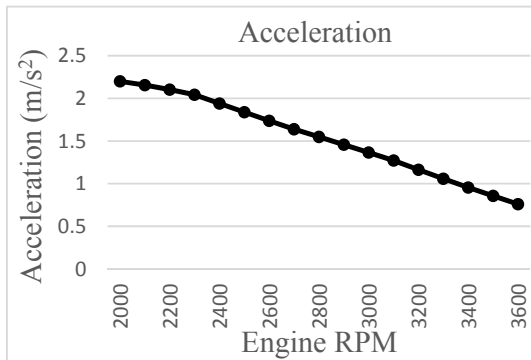

Fig. 9. Vehicle Acceleration Having Linear Variation of Speed Ratio

As shown in Fig. 10. the velocity of vehicle is varying linearly with the speed of engine and the speed ratios for the pulleys are calculated from this velocity variation keeping belt length constant. So the gear ratio obtained from this is shown in the Fig. 11.

For the same speed ratio and velocity the acceleration is calculated, which is as shown in the Fig. 10. Here the acceleration is higher at the

beginning which is good to have good pickup of the vehicle. [3]

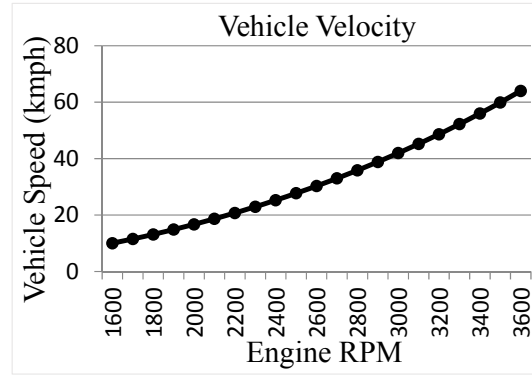

Fig. 10. Linear Variation of Speed

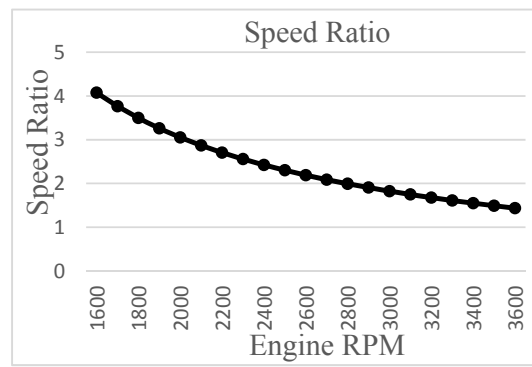

Fig. 11. Speed Ratio Variation Having Linear Variation of Velocity

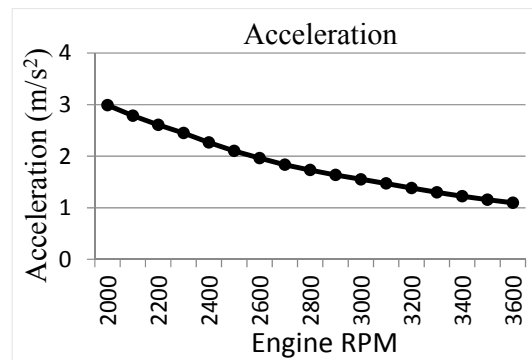

Fig. 12. Vehicle Acceleration Having Linear Variation of Vehicle Velocity

4) Pulley Dimension

Form the above speed ratio calculation and the constant belt length of 1012 mm the dimensions

of the driving (primary clutch) and driven (secondary clutch) pulley is calculated. As the standard belt have the groove angle as 30° the groove angle for driving pulley is taken as 26° and for driven pulley it is taken as 28° to have firm grip of the pulley on the belt. The minimum and maximum pitch circle diameters of the driving pulley for the calculated speed ratio are 59.1mm and 139.8 mm respectively, and for driven pulley they are 180 mm and 241 mm respectively. So the total displacement of primary pulley required for the speed ratio change from maximum to minimum is 16.4 mm and for driven pulley it is 16.34 mm.

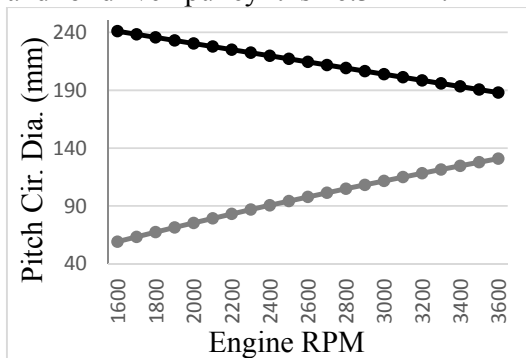

Fig. 13. Driving and Driven Pulleys Pitch Circle Diameter Variation with Engine speed

As shown in the Fig. 13. diameter of driving pulley increases and the diameter of the driven pulley decreases with increase in speed of engine. Means the speed ratio varies from 4.36 to 1.31 as the engine speed increase from 1600 RPM to 3600 RPM. Here the belt length and the centre distance between the two clutches are selected in such a way that linear variation of the pitch circle diameter of driven pulley (secondary clutch) results in linear variation of pitch circle diameter of driving pulley (primary clutch). For calculation of the pulley dimension refer the Appendix I.

5) Belt Selection

5.1) Belt Tension

From the engine supply power, pulley dimension and torque required to be transmitted the tension in the belt can be calculated. Variation in belt tension with change in the engine speed is shown in the Fig. 14. For calculation refer Appendix II.

converted into the rotating motion of the cam and the CG location of the cam. Profile of the cam is

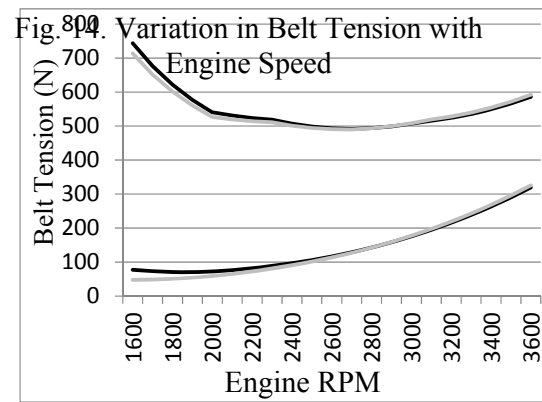

As shown in the Fig.14. the tension in the belt varies with the speed of engine, because the power and torque variation with the speed and as the speed ratio also changes with the speed of engine so torque also varies. From the graph it is cleared that the maximum tension in the belt is about 750 N, thus the normal belts can't be used for the CVT. So special CVT belt should be used to withstand this high tension. [4]

5.2) Belt Specification

Variable Speed Belt which is special type of belt for CVT is selected to withstand the higher tension. Specification of the belt is obtained from the catalogue of the Dunlop Industrial Belts, which are as follow.

- Belt Groove Angle : 30°
- Mass of Belt : 0.5 kg/m
- Belt Length : 1012 mm
- Main Cross Section : 33 mm x 10 mm

6) Variator Design

Different types of variators are used to have desired movement of the pulley, they are roller based, slider based and cam base, these all are mechanically actuated variators, while hydraulically operated and electrically operated actuators are also available. Basically all the variator is used to actuate the pulley to have the required speed ratio.

Mechanical variators are simple in construction but less accurate while the other variators are complex but accurate. In this CVT mechanical variator is used with cam based actuator, which is smoother than the roller and slider type actuators.

Cam is designed based on the displacement of the driving pulley required. This displacement is

generated in such a way that the cam is always being in contact with the slider roller.

Cam push the movable pulley of the primary clutch to make them closer to each other while the belt and the primary spring resist the motion of the pulley and try to expands the pulley. So cam has to produce enough force to overcome

the belt force and the spring force. But forces in cam is generated only due to centrifugal action. Forces generated and transmitted in primary clutch is shown in the Fig. 15. [4]

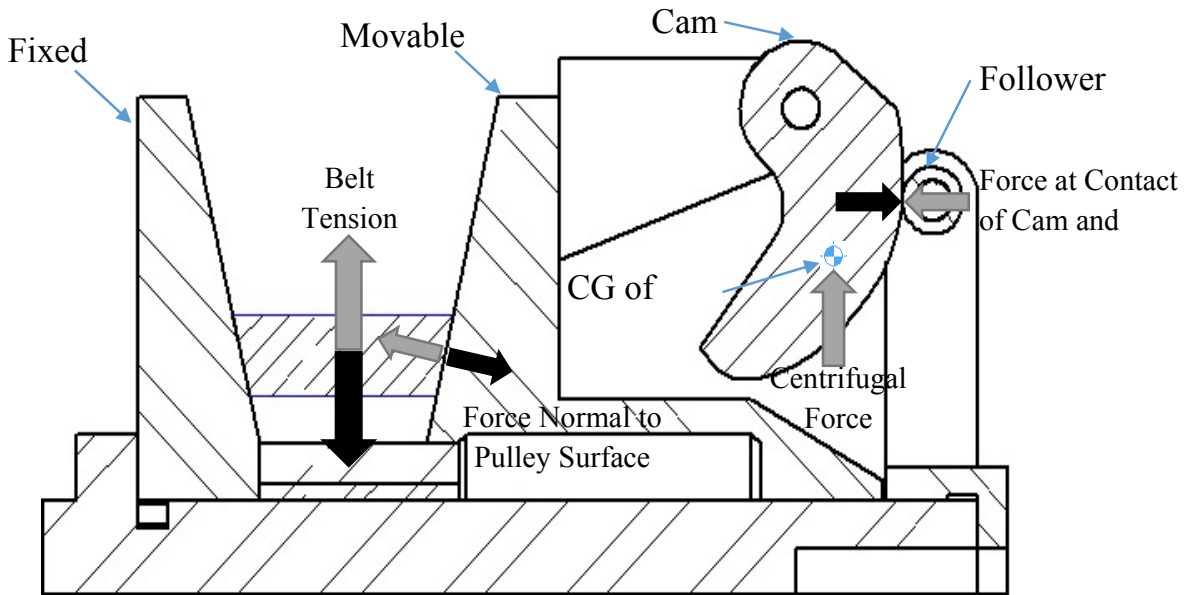

Fig. 15. Forces in the Primary Pulley

Fig. 15. shows the forces transferred from belt to cam and roller. In the Fig. 15.c the forces shown by black colour is generated due to belt tension and shows the components of the force transfer to roller. The forces shown by grey colour is generated due to centrifugal force and shows the force transfer back to belt. Half of the force generated due to belt is transferred to the movable pulley from which its component normal to surface is responsible for motion. Now this normal force produce thrust on the cam. This thrust force is transferred from cam to follower. The thrust force of belt on the follower must have the opposite and equivalent force generated by cam centrifugal force. The cam generates the centrifugal force due to rotational motion. Here the cam weight is first assumes as 56 grams and the CG of the cam is taken at 24 mm from the pin mounting. To compensate the force generated by the belt the cam profile is generated in such a way that the required force can be produced at the cam contact.

The total force generated by the belt and spring is shown in the Fig.16. It is cleared from the Fig. 16. that the force generated increase with increase of speed of engine.

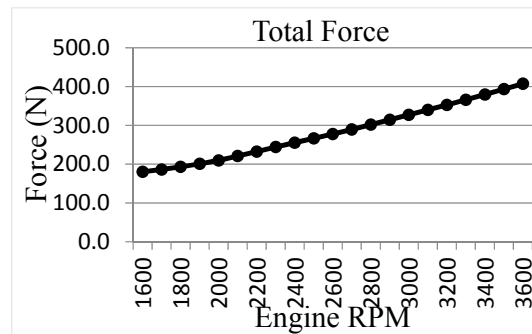

Fig. 16. Total Force generated by belt on the follower

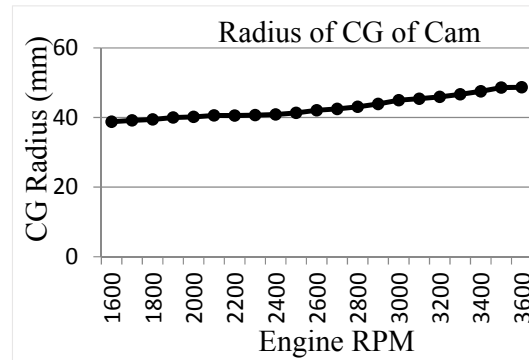

Fig. 17. Radius of rotation of CG of Cam at different engine speed

From the thrust force generated by the belt the radius of CG of Cam required to generate equal and opposite force can be calculated. Fig.17. shows the variation of the radius of CG of Cam. From the radius of rotation of the CG of the Cam and from the displacement of the movable pulley

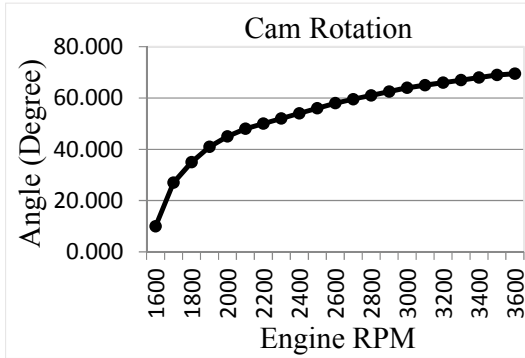

Fig. 18. Calculated Cam rotation required at different speed of engine

required the rotation of cam can be calculated. Fig. 18. show the rotation of the cam required to have the desired displacement of the pulley and to generate the enough force to keep the system in equilibrium.

Fig. 18. shows that the rotation of cam is more at the initial stage as the change in the speed ratio is more at initial stage compare to the last stage change in the speed ratio. Base on above calculation the cam profile is generated considering the radius of rotation of CG of the Cam and the rotation of the cam. The generated cam profile is shown in Fig. 19.

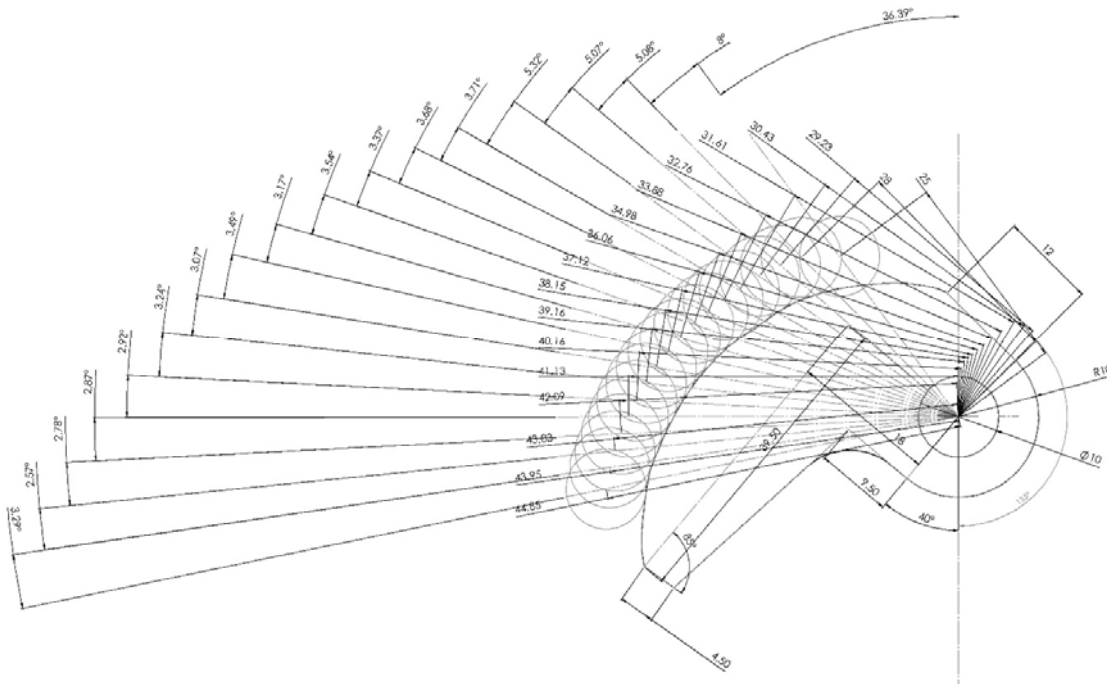

Fig.19. Cam Profile

Form the required speed ratio in CVT the displacement of the driving pulley can be calculate and it is as shown in the Fig.20. and result of the simulation is shown in the Fig.21.

Simulation of the CVT is done in the Solid Works motion analysis. In simulation the speed

of the CVT varies from 1600 RPM to 3600 RPM. The speed of CVT is 1600 RPM at 2 sec and become 3600 RPM at 18 sec, variation of speed is linear. From Fig.20 and Fig.21. it is clear that the simulation results are almost similar to the theoretical values. [4]

The secondary clutch actuates with help of belt tension and spring force, in which the belt tries to separate the pulley and spring pushes the pulleys to keep them nearer to each other. Spring stiffness for secondary clutch can be calculated as 14 N/mm.

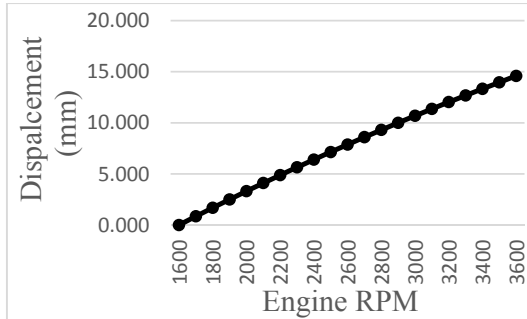

Fig.20. Required Pulley Displacement from Calculation

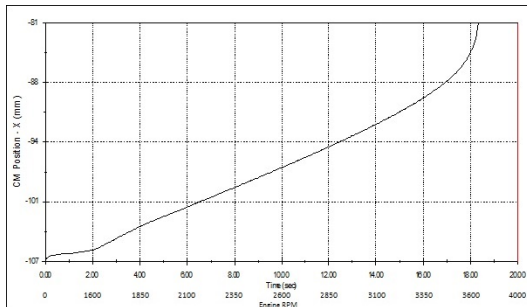

Fig. 21. Simulation Result for Displacement of Driving Pulley

7) Clutch Less Concept

In normal power train the clutch is required to start the car (engine) to shift the gear in manual transmission gear box car. But in CVT the speed reduction is changed automatically, there no requirement of gear shifting and as such the clutch. But at the same time when the car is started as the CVT is engaged with engine the car runs in ideal condition. So to prevent this motion the clutch is required, but in CVT manual clutching cannot be preferred so generally centrifugal clutch is used in the CVT. [5]

The clutch less concept is introduced in our CVT to eliminate the requirement of clutch at starting. In this concept initially play is provided between the belt and the primary pulley. So that when the engine is running in the ideal condition the belt can move freely between the primary pulleys. Thus the power is not transmitted to the secondary clutch. So to compensate this initial play the cam has to be provided with initial free rotation and same has to be introduced in the pulley movement. [5]

8) Final Drawings of Components

Fig. 22. to Fig. 26. shows the final drawing of various components of CVT designed above with its overall dimensions and images of manufactured components

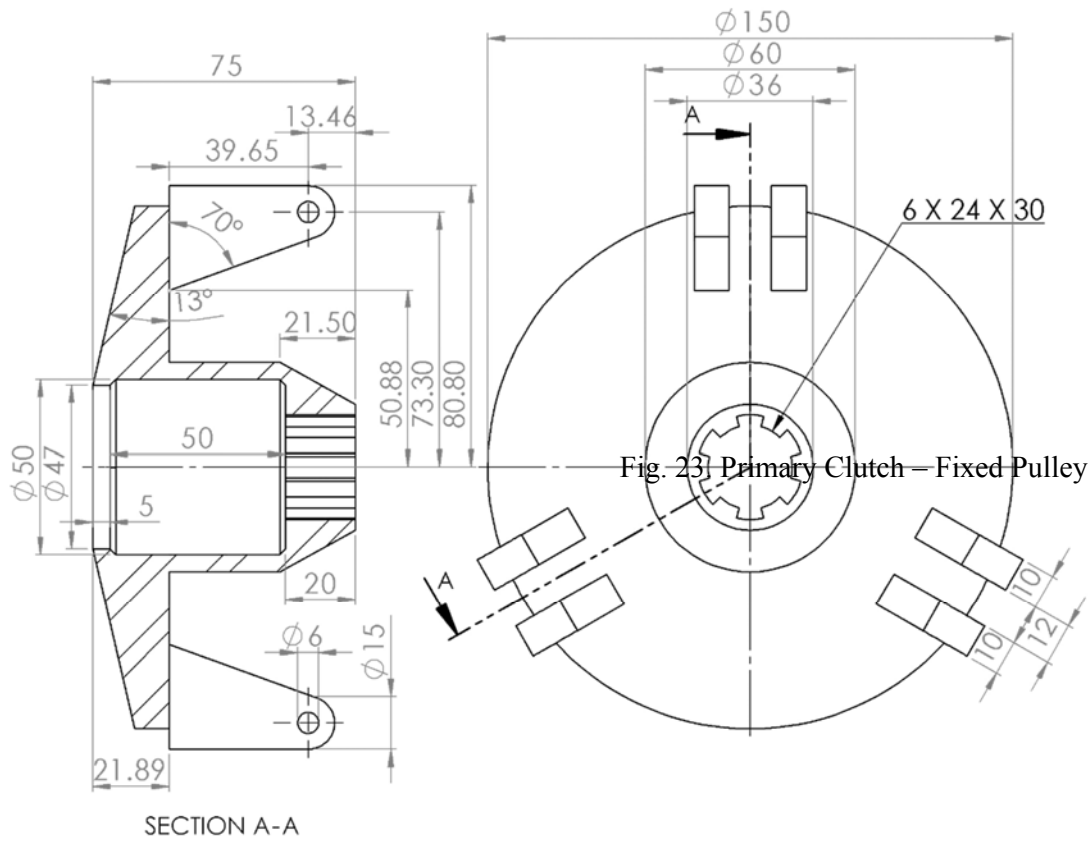
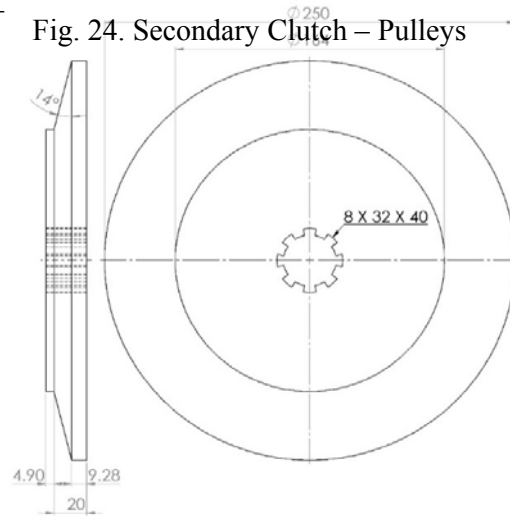
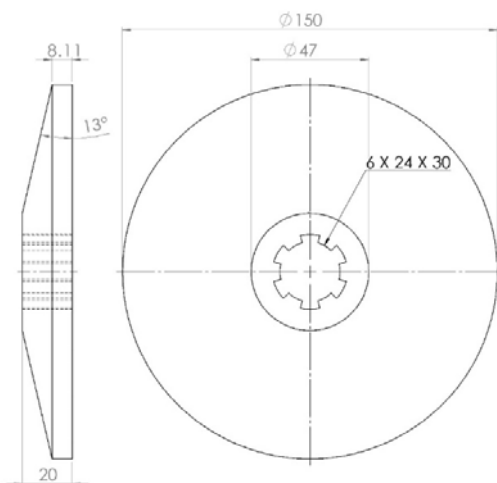

Fig. 22. Primary Clutch –

Fig. 24. Secondary Clutch – Pulleys



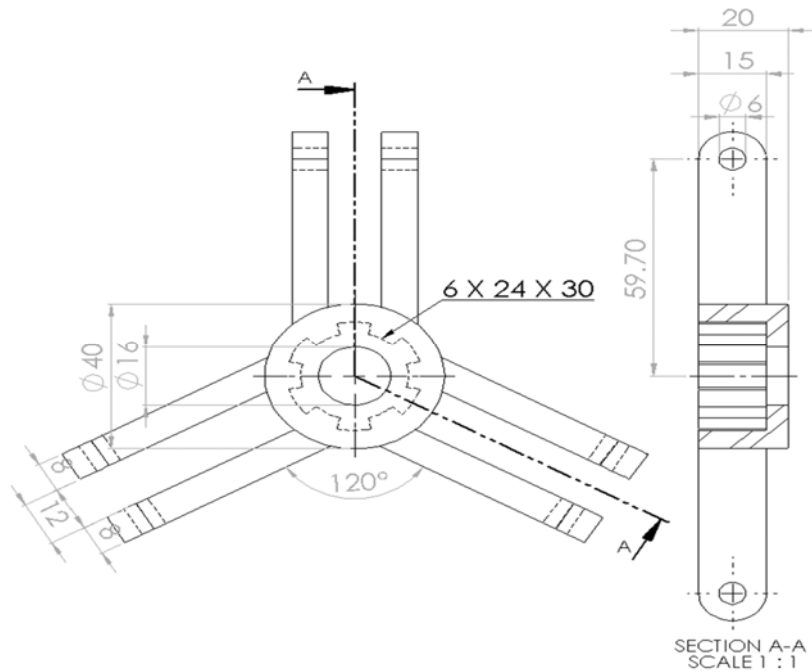

Fig. 25. Primary Clutch – Spider

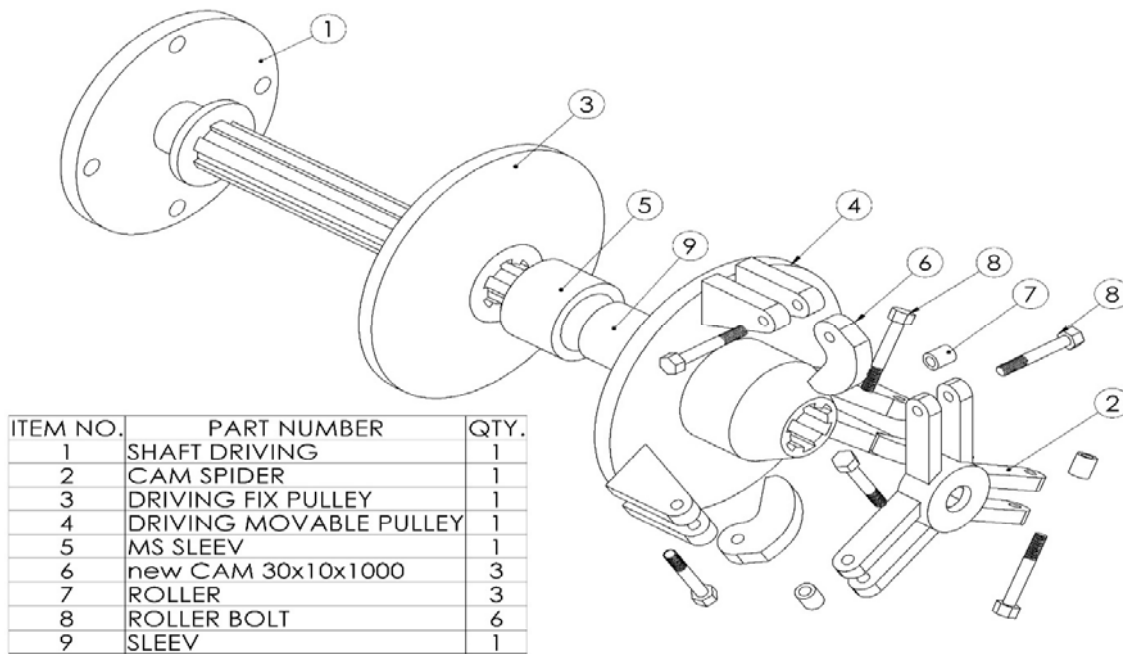

Fig. 26. Primary Clutch – Exploded View with Bill of Material

V-Performance Testing

CsVT is not a positive drive, means there will be more chances to have power loss. So it required to test the performance of the CVT in its working conditions and environment. For testing the CVT the output power, torque and the speed ratio are required to check. In the experiment the torque is measured with help of rope brake drum dynamometer and the speed of input shaft (engine shaft) and the output shaft (secondary clutch) is measured with help of tachometer. [6] Outcome of rope brake drum dynamometer is weight shown by the weight scale. From which the torque at the output shaft can be calculated by multiplying it with the radius of drum. And

power output can be calculated from this torque and the rotational speed of the output shaft.

1) Speed Ratio

Speed ratio is obtained by measuring the RPM of the input shaft (Engine shaft) and the output shaft (Secondary clutch). Fig. 27. shows experimental results for the variation of the speed ratio varying with change in the RPM of engine.

From Fig. 27. it is clear that the experimental speed ratio achieved is varying same as the theoretical speed ratio. But the experimental speed ratio is less compare to theoretical speed ratio, which may be caused due to slip between belt and the pulley as it a non-positive drive. [6]

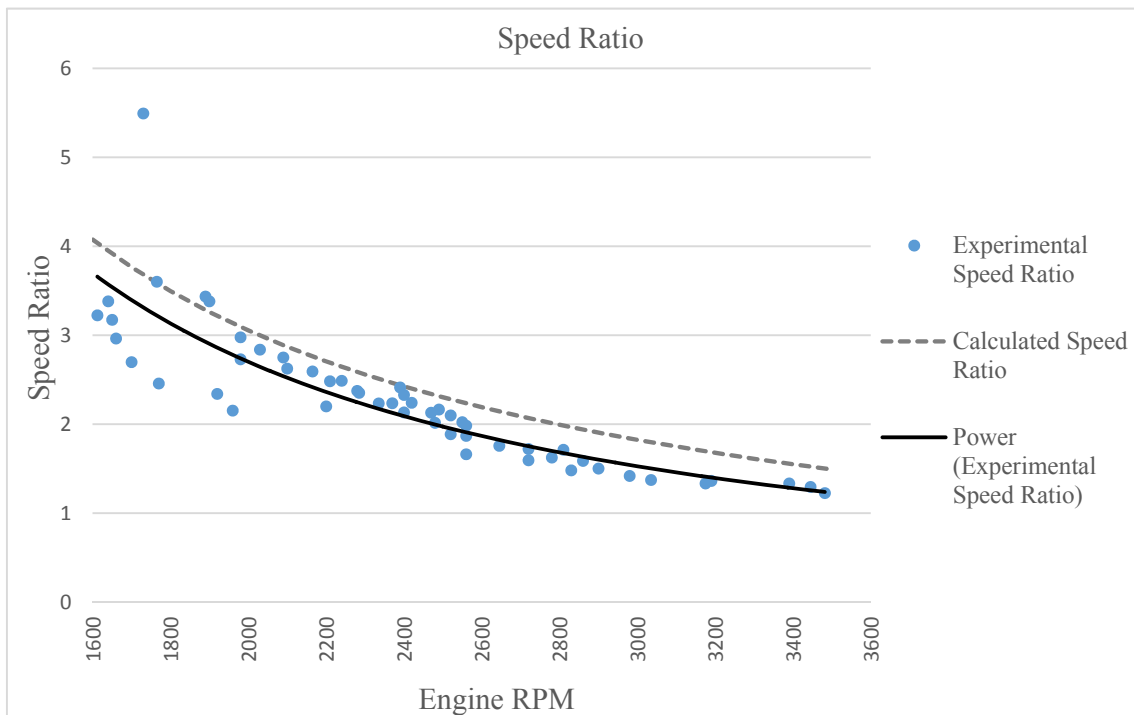

2) Efficiency

Efficiency of the system can be calculated from the ratio of output power to input power. Here the input power is from engine which can be obtained from the engine power curve, while the output power can be calculated from torque and the speed of the output shaft (secondary Clutch). Fig. 28

shows the efficiency of the CVT at various speed of the engine.[7]

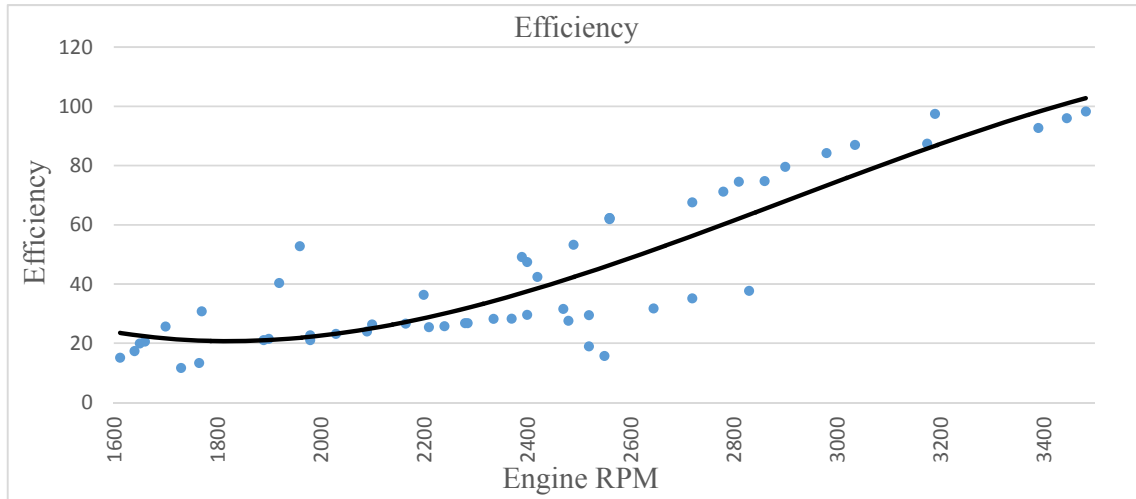

Fig. 28. Efficiency of CVT at Various Engine Speed

From Fig.28. it is clear that the efficiency of the CVT is very less at the starting but as the speed increase the efficiency also increase. This happens due to the clutch less concept because in that initially there is some play is provided between the belt and the pulley so it don't provides the firm contact between them, but as speed increase due to centrifugal force normal gripping force increase and the losses is reduced. More over as it is non positive dive the losses due to slip also take place and the efficiency may further reduced. During measurement of the torque the rope brake drum dynamometer also has some frictional and heat losses so that has to be take care in the final efficiency of the CVT.

VI - Conclusion

Form the experiments the results obtained shows that the efficiency of the CVT at lower RPM of engine is low as enough centrifugal force is not generated by the cam. As well as when the speed increase the output torque obtained is not as much as designed, for this one additional component can be introduced in the secondary clutch. This component has helix which determine the required output

torque and by this it adjust the speed ratio and thus by reducing the speed the required torque can be obtained from the CVT.

Due to manufacturing defect of components like imbalance in component the performance of the CVT will be affected. More over the measuring instrument for torque also has some losses in terms of heat loss. And the components are made from mild steel so the components are heavier and has more inertia, so the losses in the components due to higher inertia is more. So these components can be made from the lighter material like aluminum.

Appendix – I: Pulley Dimension

Centre distance between pulleys (C) = 10 inches = 0.254 m

Belt Length (L) = 0.915 m

Driven pulley diameter (D) = assuming
Driving pulley diameter (d) = $D - \pi C +$

$$2C \sqrt{\left(\frac{\pi}{2} - \frac{D}{2C}\right)^2 - \frac{1}{C} \left(\frac{\pi}{2} D + \frac{D^2}{4C} + 2C - L\right)}$$

Pulley grove angle (α) = 26°

Variation in the diameter of driving pulley (t)
= 139.8 – 59.1 = 80.7 mm

Variation in the diameter of driven pulley (T)
= 241 – 180 = 161mm

Total displacement of the driving pulley =
 $(t/2)*\tan(\alpha/2) = (80.7/2)*\tan(13) = 18.6 \text{ mm}$

Total displacement of the driven pulley =
 $(T/2)*\tan(\alpha/2) = (161/2)*\tan(14) = 15.2 \text{ mm}$

Appendix II - Belt Tension

Mass of Belt (m) = 0.5 kg/m

Co efficient of friction between belt and pulley (μ) = 0.2

Power transmitted (Power output from engine) = P

Angle of wrap = θ

Velocity of belt (v) = $(\pi * D * n) / (60 * 1000)$ [8]

Tension in slag side (P_2) = $mv^2 +$

$$\frac{P*1000}{v*(e^{\frac{\mu\theta}{\sin(\frac{\alpha}{2})}}-1)}$$

Tension in tight side (P_1) = $P_2 + P*1000/v$

Appendix 3 - FINAL CVT AND SETUP



Figure 29 : Manufactured CVT

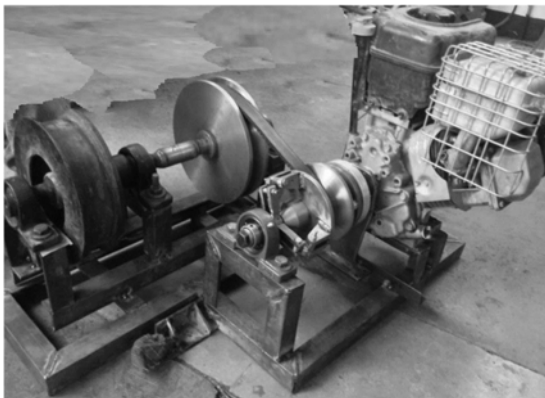

Figure 30 : CVT with Test setup

REFERENCES

[1] Kevin R. Lang , 2000 , “Continuously Variable Transmissions, An Overview of CVT Research Past, Present, and Future”.

[2] Norman H. Beachley and Andrew A. Frank , 1979 ,” CONTINUOUSLY VARIABLE TRANSMISSIONS:THEORY AND PRACTICE” , College of Engineering ,University of Wisconsin, Madison.

[3] Kluger, M. and Fussner, D., 1997, “An Overview of Current CVT Mechanisms, Forces, and Efficiencies,” SAE Technical Paper No. 970688.

[4] Kluger, M. and Long, D., 1999, “An Overview of Current Automatic, Manual and Continuously Variable Transmission Efficiencies and Their Projected Future Improvements,” SAE Technical Paper No. 1999-01-1259.

[5] Hewko, L., 1986, “Automotive Traction Drive CVTs – An Overview,” SAE Technical Paper No. 861355.

[6] Fenton, J., 1996, “Handbook of Vehicle Design Analysis,” Society of Automotive Engineers, Inc., Warrendale, PA, Ch. 19.

[7] Hyunsuk Kim Hyundai Motor Company, 772-1, Changduk-dong, Whasung-shi; Kyunggi-tio, 445-706, Korea.

[8] Allen, Mark and LeMaster, Robert. “A Hybrid Transmission for SAE Mini Baja Vehicles”,SAE Publication 2003-32-0045.