



POWER QUALITY IMPROVEMENT & THD ANALYSIS OF 23-LEVEL 3-Ø SYMMETRIC CASCADED H-BRIDGE MULTI-LEVEL INVERTER WITH DIFFERENT AMPLITUDE MODULATED MULTICARRIER LEVEL SHIFT PWM TECHNIQUES

P.Shiva Sai Sagar¹, K.H.Phani Shree²

¹M.Tech. PTPG Student, University College of Engineering, JNTU-Hyderabad.

²Professor & Coordinator EDC, University College of Engineering, JNTU-Hyderabad.

Abstract:-

The importance of Multi-Level inverters has been increased since last decade as they are popular for synchronizing the renewable energy sources with AC Grid and found many applications in electric utility and for industrial drives. Multilevel inverters have been recognized as economical alternative in high power and medium voltage applications due less harmonics and high power ratings. Till today several Topologies have been implemented on multilevel inverters, from which the Cascaded H-Bridge MLI topology is adopted due to its modularity and simplicity to control. Cascaded H-Bridge Multilevel inverters are flexible to generate any number of output voltage levels and can be controlled by various modulation techniques (such as sinusoidal PWM (SPWM), 60° modulated sinusoidal PWM (SDPWM), selective harmonic elimination PWM (SHE-PWM), space vector PWM, third harmonic injected PWM (THPWM) and trapezoidal PWM (TRPWM)) & the paper is proposed on simplified simulation model of “3-Ø symmetric cascaded H-bridge multi-level inverter with various amplitude modulated Multicarrier level shift PWM techniques” (Amplitude modulated mutli carrier (AM-MC)- Phase in Phase Disposition, AM-MC Alternate Phase opposition and Disposition & AM-MC Phase opposition) for N-Level generation. The proposed amplitude modulated Multicarrier level shift PWM technique is validated from three phase 3-Level to Three Phase 23-Level

& have been simulated on Matlab/Simulink platform and the relevant %Total harmonic distortion (THD), %Magnitude of 3rd, 5th & 9th order Harmonics, Vrms, Irms, V-peak, I-Peak, Duty cycle etc., are compared which are evaluated by Fast Fourier Transformation (FFT) analysis of the output Voltage & Current waveforms.

Keywords:- CHB (Cascaded H-Bridge), MLI (Multilevel Inverter), THD (Total Harmonic Distortion), MCPWM (Multi carrier pulse width modulation), AM-MC-Amplitude modulated multi carrier, AM-MCPID (Amplitude modulated Multi carrier Phase in Phase Disposition), AM-MCAPOD (Amplitude modulated Multi carrier Alternate Phase opposition and Disposition) & AM-MCPO (Amplitude modulated Multi carrier Alternate Phase opposition).

I. Introduction:-

The consumption of electricity is growing day by day and proportionally the electricity generated must also be increased. Due to deficiency in fossil fuels and problems encountered with in the environment that are caused by Conventional power generation & in order to meet the increasing load demand now a days the renewable energy becomes very demanding & also they offer pollution free energy.[1]. Therefore now a days “Distributed Generating Stations” are going to be installed at the load centers especially in villages for which in most of the cases the source of electricity is renewable (solar energy) only. To connect the renewable energy sources with the AC grid there should be matching in voltage and frequency

which can be achieved through Multilevel Inverters. Although there are conventional two level & three level inverters which can generate AC Voltage effectively yet there are many limitations in handling high voltage and high power conversion.[2] That is, for higher output voltage capacity and reduction in harmonic distortion, these conventional converters are connected in series using transformers, which are the main contributor to problems such as bulkiness, high loss and high cost to the overall AC system and also it produces harmonic distortions in the voltage at output and has a high voltage stress dv/dt in comparison with MLI's.

With the usage of MLI's over conventional two & three level invertors the MLI's offers the following benefits:-

- MLI offers high degree of freedom to control the output in terms of number of output levels, modulation indices of amplitude and frequency, step size & switching angles.
- As stresses on the switching devices (Solid state) will be decreased corresponding with the output voltage, it is possible to avoid the bulky and expensive transformer which allows decreasing the overall size and economical AC System.
- Due to reduced rate of change of voltage i.e. dv/dt stresses on switching devices may enhance the life time of the load and electromagnetic compatibility problems are also reduced.
- MLI generates staircase waveform as output which is nearly sinusoidal. This improves the P-Q (Real & Reactive) profile and harmonic profile which allows drastically reduction in the filter size [3] and even may eliminated if the Total Harmonic Distortion (THD) is less than the prescribed limit as per IEEE:519.

MLI Topologies:-

MLI Topologies of can be classified as follows:-[4]

- Diode Clamped or NPC MLI.
- Flying Capacitor MLI.
- Cascaded H-Bridge (CHB) MLI.

Among these topologies, a survey on CHB [5] has been done and concluded that it has become an attractive topology due to its modularity and simplicity to control. Moreover the CHB-MLI

has gained special consideration due to its flexibility to generate any number of output voltage levels, high reliability & is economical [6] moreover no clamping devices such as capacitor or diode is required. Moreover, this CHB-MLI are found to be attractive for grid connected PV applications [7]. The main advantages of the cascaded multilevel inverters are that the regulation of the DC buses are simple, require less number of switching devices & reduced voltage unbalancing problems. Many modulation techniques have been proposed in which Pulse width modulation technique plays a vital role in multilevel inverters to get the desired output voltage levels. CHB-MLI topology can be implemented as symmetrical or asymmetrical type. In symmetrical type CHB-MLI, the amplitude of all DC voltage sources is equal & in later case it is vice versa.

Modulation techniques:-

Several Modulation techniques are introduced in the literature such as:-

selective harmonic elimination PWM (SHE-PWM), space vector PWM, sinusoidal PWM (SPWM), third harmonic injected PWM (THPWM), 60° modulated sinusoidal PWM (SDPWM) and trapezoidal PWM (TRPWM) (SVPWM) and multi-carrier PWM (MCPWM). As universally, no system is one sided, every modulation techniques have their own advantages & disadvantages.

The main challenge associated with the SHE-PWM and SVPWM techniques is, complexity in calculations in multilevel inverter operation over 5-levels. In recent number of literature, authors have proposed the method to mitigate the CHB power balancing problem using level shifted PWM techniques only.

SPWM is the commonly used reference signal due to its simplicity to generate it. THPWM, SDPWM and TRPWM reference signals are used where linear modulation is required by flattening the top of these reference signals. Carrier signals and modulating signals both provides freedom in amplitude, frequency and phase. So based on combination of carrier signals and modulating signals, number of multilevel PWM output can be generated [8].

The main aim of this paper is to present a simplified way to generate simulation model for 3- ϕ symmetric cascaded H-bridge multi-level inverter with various amplitude modulated Multicarrier level shift PWM (AM-MCLS)

techniques from 3-Level (3-phase) to 23-Level (3-phase) and to analyze their performance based on %Total harmonic distortion (THD), %Magnitude of 3rd, 5th & 9th order Harmonics, Vrms, Irms, V-peak, I-Peak, Duty cycle, No. of switching devices etc., up to 23-level three phase CHB inverter. The generation of various amplitude modulated multi-carrier (AM-MC) signals will be same for N-Level generations & the AM-MC-LS techniques are validated on MATLAB/ SIMULINK platform. The paper is as follows

Section II- Describes configuration of CHB (single cell) along with 5-Level 3-Ø Symmetrical CHB MLI.

Section III-Shows 23-level 3- phase Symmetrical CHB MLI & its connection diagram.

Section IV-Describes Classification of PWM modulation techniques & AM-MCLS.

Section V-Overview to develop various AM-MC signals.

Section VI- Generation of control pulses for CHB-MLI.

Section VII- Simulation results & Comparisons.

Section VIII- Conclusion

Section IX-Future scope.

II. CONFIGURATION OF CHB INVERTOR:-

a) Single H-Bridge Cell :- (Three-Level MLI)

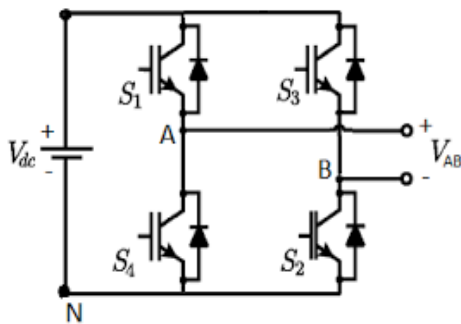

Fig.1

A single cell of CHB structure of a three level cascaded inverter is illustrated in Figure1. Each H-Bridge inverter cell shall generate 3-Levels of output by different switching combinations of solid state switches i.e., S1, S2, S3 & S4 and are as follows

Combinations of Switches in ON State	Output Volatge V _{AB}
S1,S2	+V _{dc}
S3,S4	-V _{dc}
S1,S3	0

The ac outputs of each H-Cell are connected in series such that the synthesized voltage waveform is the sum of the inverter outputs. The number of output phase voltage Levels “n” in a CHB MLI is given by n = 2h+1, where h is the number of H-bridges to which a separate dc source is connected.[8]

b) 5-Level Cascaded H-Bridge MLI Configuration:-

(i) 1-Ø 5-Level CHB-MLI:-

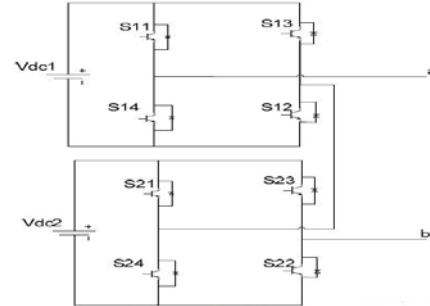

Fig.2

The circuit arrangement of a single phase five level CHB-MLI is shown in fig. 2 consisting of two single

CHB Cells connected in series with separate DC source. In symmetrical mode for ‘x’ number of separate DC sources; the output voltage level will be 2x+1. Hence two separate DC sources produce voltage levels of +2Vdc, +Vdc, 0, -Vdc & -2Vdc in symmetrical mode with different switching combinations.

(ii) 3-Ø 5-Level Symmetrical CHB-MLI:-

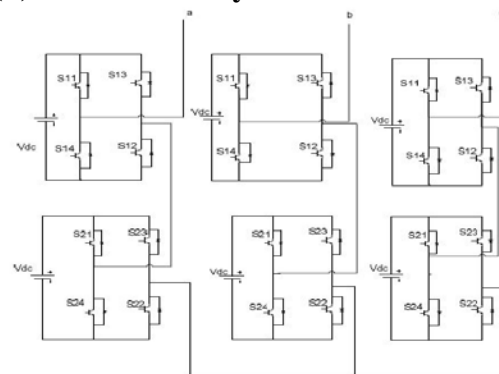

Fig.3

The above Fig.3 shows the 3-Ø 5-Level symmetrical CHB MI & for Symmetrical operation V_{dc1} = V_{dc2} & the output voltage of the inverter is the sum of the each inverter’s phase voltage i.e., Vab = Vao+Vbo. All the possible combination of switching sequence for five levels is shown in the following table in which

- 1- Indicates conducting state of a switch and
- 0- Indicates non- conducting state of the switch.

Vab	S11	S12	S21	S22
+2Vdc	1	0	1	0
+Vdc	1	0	1	1
	1	0	0	0
	1	1	1	0
	0	0	1	0
0	0	0	0	0
-Vdc	0	1	1	1
	0	1	0	0
	1	1	0	1
	0	0	0	1
-2Vdc	0	1	1	0

Likewise, each cell of H-Bridge are cascaded in each phase and No. of H-Cells required in N-Level generation is given by $H=(N-1)/2$, Such that the output waveform is synthesized cascaded waveform of all the H-Bridges per phase.

III. 23-Level 3-Phase Symmetrical CHB MLI:-

As stated in above sections, each individual phase of 23-level 3-phase Symmetrical CHB-MLI constitutes 11 CHB's i.e., $H=(N-1)/2=(23-1)/2=11$ CHB's & all are connected in series such that the synthesized ac output voltage waveform is the sum of the each inverter (H-cell) output. & Matlab-Simulink model is shown below.

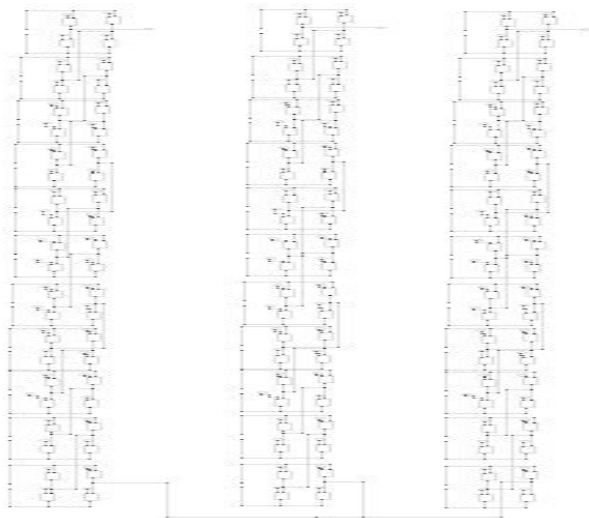

23-level 3-phase Symmetrical CHB-MLI

Each phase produces 23-levels of output through 11 H-cells connected in series with improved performance that are later compared in simulation results section.

IV. Various Modulation Techniques:-

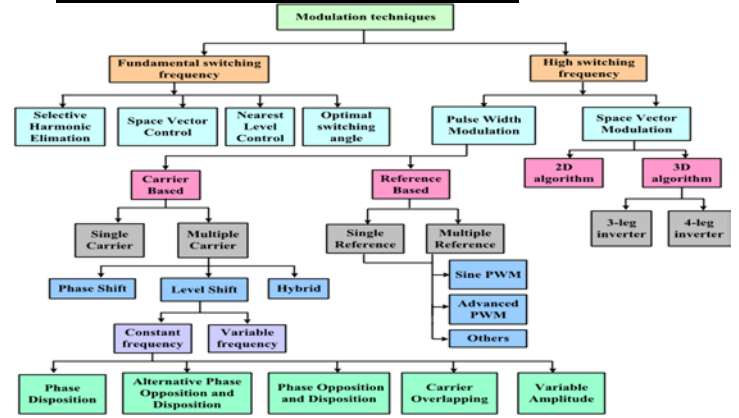

Fig.5

The modulation techniques are broadly classified as Shown in above Fig.5 and are summarized as follows

(i) Fundamental Switching Frequency Modulation:-

The main challenge associated with the fundamental switching frequency modulation technique is that, the SHE-PWM and SVPWM techniques is that, complexity in control operation of switches for voltage levels above 5level and as the number of levels increases the nearest level & optimal switching modulation strategy requires more complicated equations which is not advisable.

(ii) High switching Frequency Modulation:-

As described in Fig.5 among the various High switching frequency modulation techniques “Carrier based level shifted constant frequency multi-carrier PWM techniques” possess higher advantages to control and to generate high quality output waveform, easy to implement switching Waveforms & its simplicity [9]. Multi-carrier PWM is broadly classified as two types

1. Multi-carrier level shift PWM
 - Phase in-phase disposition (PID).
 - Phase opposition disposition (POD).
 - Alternative phase opposition disposition(APOD).

2. Multi-carrier phase shift PWM

The main drawback of multi-carrier phase shift PWM technique is that, it shows worse line to line voltage THD profile compared to Multi-carrier level shift PWM techniques.

1.(a) Amplitude Modulated Multi-Carrier Level shift PWM Techniques:- (AM-MCLS-PWM)

The AM-MCLS-PWM technique is the most widely used and well accepted because it is the simplest technique to generate multilevel pulses

to control individual power switches for any output level inverters by comparing reference signal with triangular signals[9]. Likewise, in the Amplitude Modulated Multi-Carrier Level shift PWM techniques the “amplitude of carrier waves” are controlled i.e., amplitude is changed w.r.t No., of levels and are broadly classified as:-

- a) **AM-MCLS-PID Technique**
- b) **AM-MCLS-APOD-Technique**
- c) **AM-MCLS-PO Technique**

Now, in order to obtain lower %THD and various other parameters here amplitude modulated multicarrier level shift PWM techniques are used and are implemented from 3-Ø 3-Level to three-phase 23- level cascaded MLI with R-L Load.

IV. Amplitude Modulated Multi-Carrier Level shift PWM techniques:-
(AM-MCLS-PWM)

The AM-MCLS-PWM methods are used in the controlling of MLI’s where power balancing is not required. In the AM-MCLS-PWM methods all the carrier signals used here are triangular signals which cover the total extent range of converter output voltage and consist of varying amplitude and of constant frequency. They are classified based on the position of carrier signals w.r.t to the reference axis [9]. For generation of N-levels, “N-1” carrier signals are required and are as follows:-

No. of Levels	No. of Carriers (N-1)	No. of Levels	No. of Carriers (N-1)
5	4	15	14
7	6	17	16
9	8	19	18
11	10	21	20
13	12	23	22

a) AM-MCLS-PID Technique:-

In this technique all the multiple triangular carrier waves are selected with same phase and different magnitude and are superimposed on the reference sinusoidal wave to generate the train of switching pulses for solid state devices of CHB’s & the AM-MCLS-PID per phase (here R-Ø) of a 3-Ø System for various levels (randomly selected) are shown in following figures:-

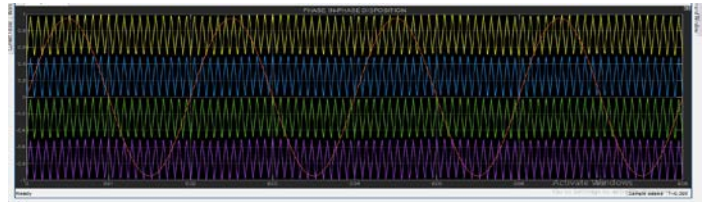

Fig.5-AM-MCLS-PID-PWM-For 5-Level CHB MLI

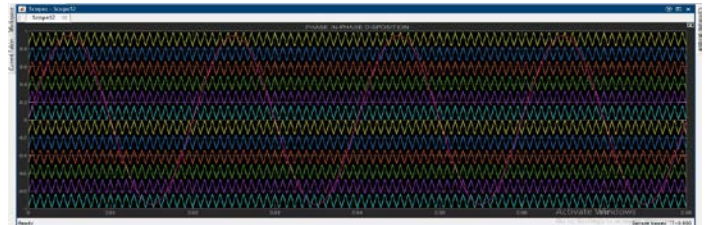

Fig.6-AM-MCLS-PID-PWM-For 13-Level CHB MLI

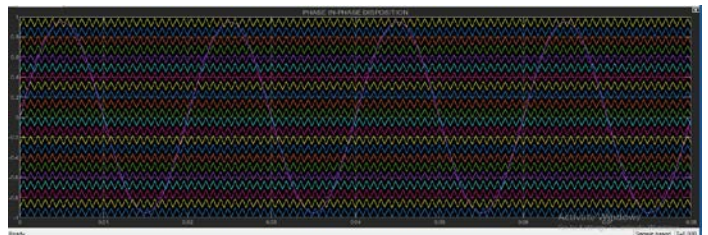

Fig.7-AM-MCLS-PID-PWM-For 23-Level CHB MLI

b) AM-MCLS-APOD Technique:-

In this technique all the multiple triangular carrier waves are selected with different magnitude and are Alternate 180° shifted with its neighbor demonstrated [9] i.e., each carrier of this method is phase shifted by 180 degrees from its adjacent carrier & the AM-MCLS-PID per phase (here R-Ø) of a 3-Ø System for various levels (randomly selected) are shown in following figures:-

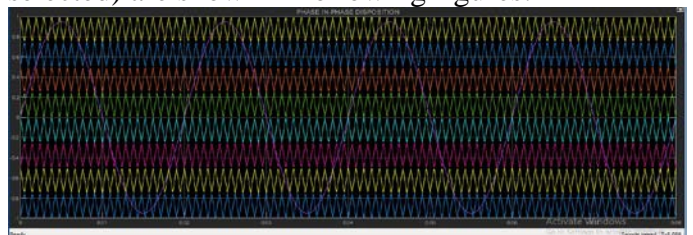

Fig.8-AM-MCLS-APOD-PWM-For 9-Level CHB MLI

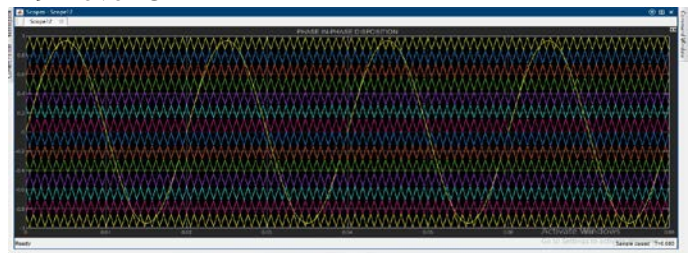

Fig.9-AM-MCLS-APOD-PWM-For 15-Level CHB MLI

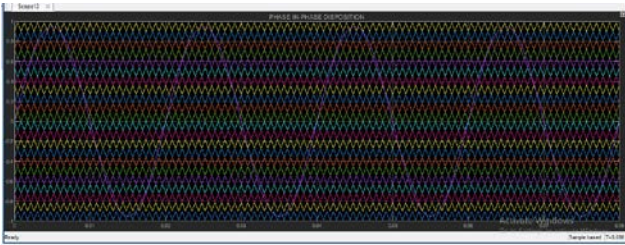

Fig.10-AM-MCLS-APOD-PWM-For 23-Level CHB MLI

c) AM-MCLS-PO Technique:-

In this technique all the multiple triangular carrier waves are selected with different magnitude and the carrier signals above the zero axes and below the zero axes are 180° out of phase but the carriers above the zero axes are in same phase and the carriers below the zero axes are in same phase & the AM-MCLS-POD per phase (here R-Ø) of a 3-Ø System for various levels (randomly selected) are shown in following figures:-

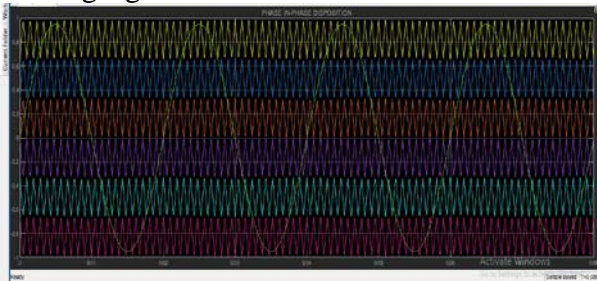

Fig.11-AM-MCLS-PO-PWM-For 7-Level CHB MLI

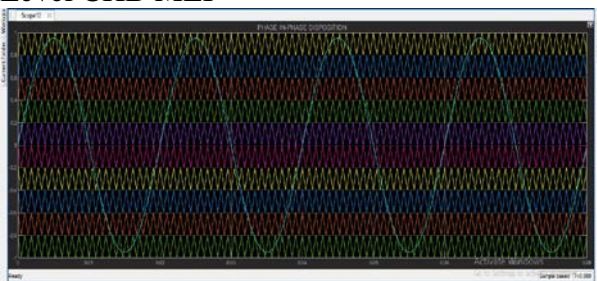

Fig.12-AM-MCLS-PO-PWM-For 11-Level CHB MLI

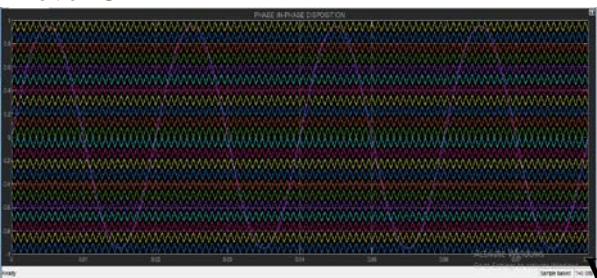

Fig.13-AM-MCLS-PO-PWM-For 11-Level CHB MLI

Likewise, all the AM-MCLS-PWM Techniques are implemented in all the three phases (i.e., R,Y, B) of the system and are simulated up to 23-Level.

VI.GENERATION OF AM-MCLS- PWM -SIGNALS:-

The modulating signal of each phase in a 3-Ø system is compared with the carrier signals at each instant.

- If the modulating signal is greater than zero with the positive carriers then it will generate '1' otherwise '0'.
- If the modulating signal is greater than zero with the negative carriers then it will generate '-1' otherwise '0' [13].

Amplitude modulation Index “M_a”

For AM-MCLS-PWM the amplitude of each carrier changes w.r.t the level of MLI. In general for a CHB multilevel inverter the amplitude modulation index is defined as the ratio of amplitude of reference wave (A_m) to the amplitude of carrier wave (A_c) [10]

Amplitude modulation Index “M_a” = (A_m)/(A_c)

Amplitude of each carrier (A_{car}):- Whereas for

Amplitude modulated Multi carriers (AM-MCLS) the amplitude of each carrier wave is defined by-[11]

Amplitude of each carrier (A_{car})= (A_m)/(N-1)*M_a [11]

Where, N-is No. of levels

For example:-

- For 3-Level AM-MC-Amplitude of each Carrier/ phase=1/(3-1)*1=0.5.
- For 9-Level AM-MC-Amplitude of each Carrier/ phase=1/(9-1)*1=0.125.

Likewise the amplitudes of each carrier in AM- MCLS - PWM techniques changes w.r.t to the level of inverter and is determined and implemented from 3-Ø 3-Level CHB MLI to 3-Ø 23-Level CHB MLI.

Frequency modulation Index “M_f”:-

The frequency ratio (M_f) is defined as the ratio of carrier frequency (f_c) to the reference frequency (f_m) given by “M_f” = (f_c)/ (f_m) [11]

Here, the simulated model for 23-levels adopts constant frequency with M_f=1 but with different amplitudes of carrier signals.

VII. SIMULATION RESULTS

To analyze the proposed simplified method to generate AM-MCLS PWM techniques have been theoretical discussed in the recent sections & these AM-MCLS-PWM technique have been conducted from 3-level 3-Ø symmetrical CHB inverter to 23-level 3-Ø symmetrical MLI having equal DC voltage sources of 10V with

Inductive load i.e., R-L load having $R=10\Omega$ & $L=5mH$, with fundamental reference frequency of 50Hz, and frequency modulation index of (M_f) 1. The variation of harmonic distortion with modulation index, Line voltages, %THD, $V_{r.m.s}$, $I_{r.m.s}$, V_p , I_p , %Magnitude of 3rd, 5th, 7th & 9th order harmonics, No. of switching devices, No. of CHB's along with duty cycle of the MLI have been analyzed for various AM-MCLS-PWM Techniques using MATLAB/SIMULINK platform and results are as follows:-

a) AM-MCLS-PID Technique:-

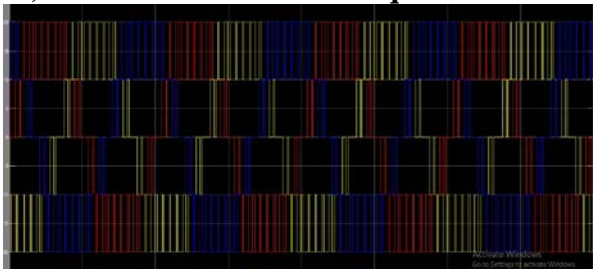

(i)Line Voltage of 5-Level CHB MLI

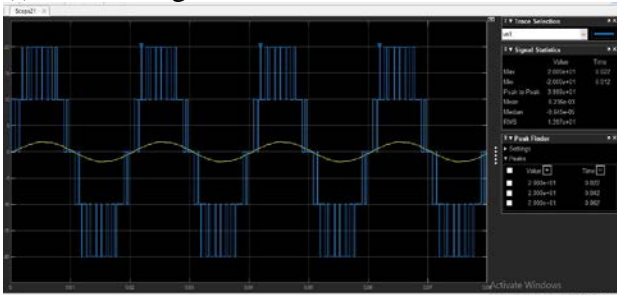

(ii)Phase Voltage & Current of 5-Level CHB MLI

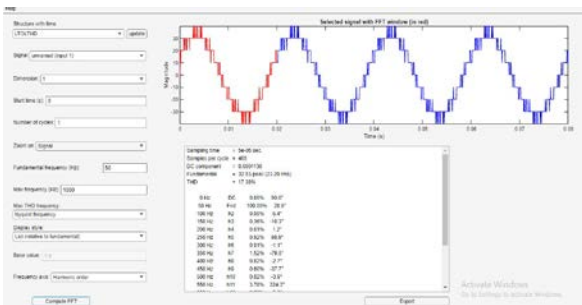

(iii)%Magnitude of 3rd,5th,7th & 9th of 5-Level CHB MLI

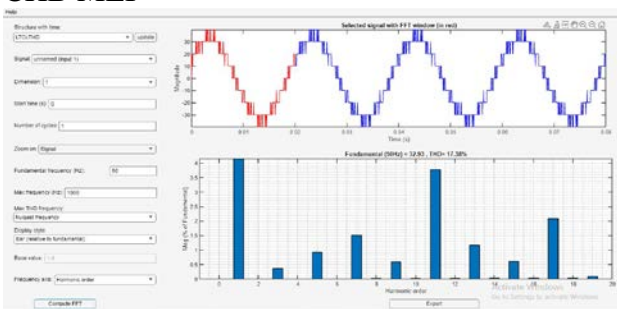

(iv) FFT Analysis of %THD of 5-Level CHB MLI

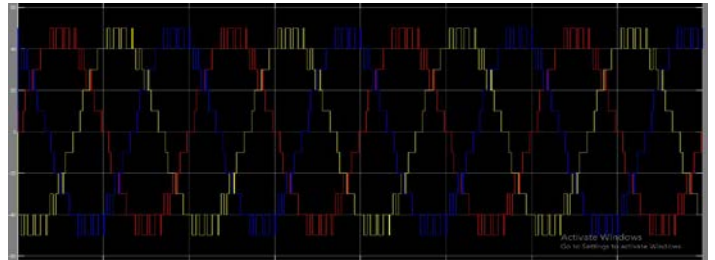

(i)Line Voltage of 11-Level CHB MLI

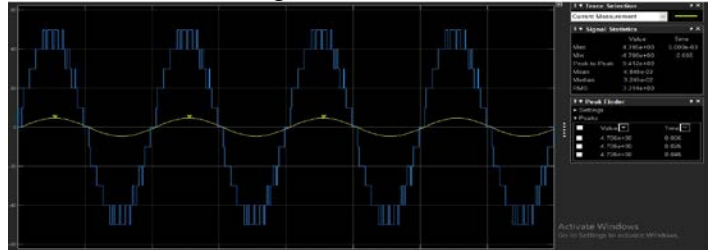

(ii)Phase Voltage & Current of 11-Level CHB MLI

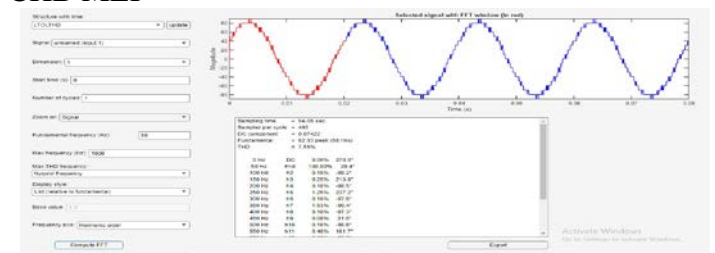

(iii)%THD & %Magnitude of 3rd,5th,7th & 9th of 11-Level CHB

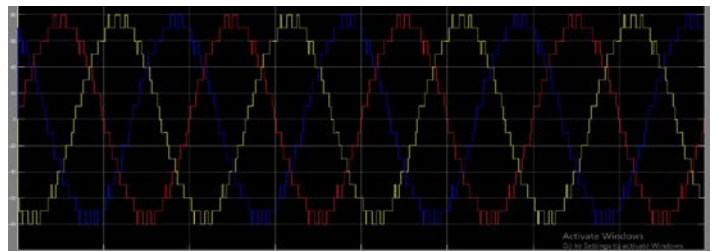

(i)Line Voltage of 17-Level CHB MLI

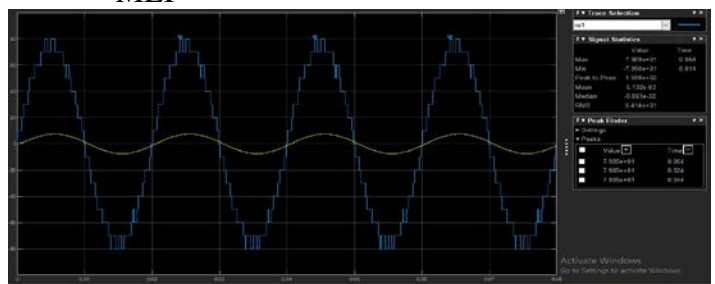

(ii)Phase Voltage & Current of 17-Level CHB MLI

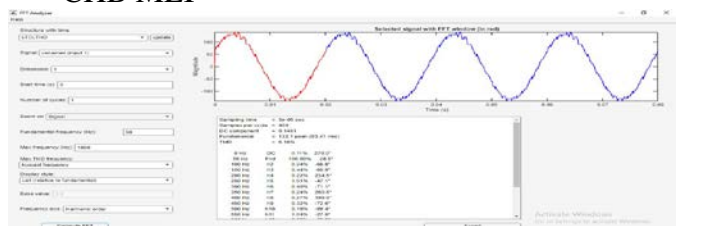

(iii)%THD & %Magnitude of 3rd,5th,7th & 9th of 17-Level CHB

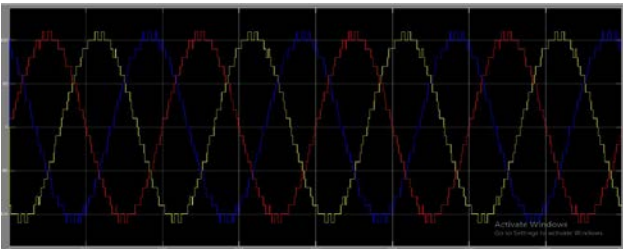

(i) Line Voltage of 23-Level CHB MLI

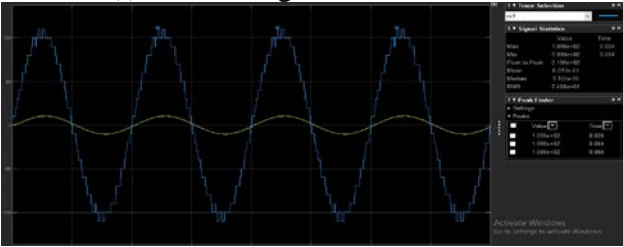

(ii) Phase Voltage & Current of 23-Level CHB MLI

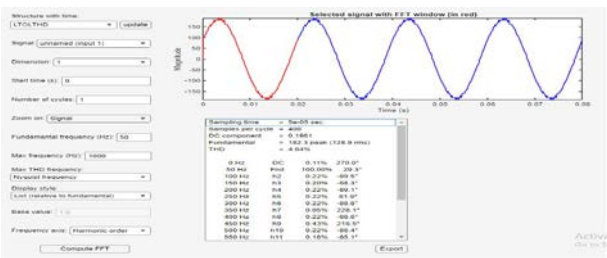

(iii) %THD & %Magnitude of 3rd, 5th, 7th & 9th of 23-Level CHB MLI

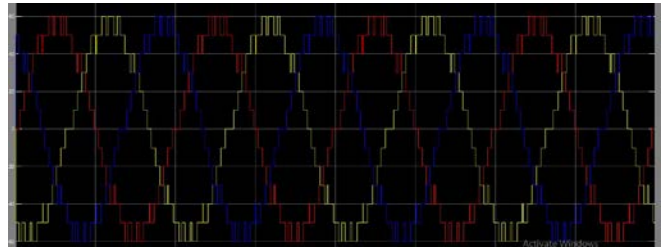

(i) Line Voltage of 13-Level CHB MLI

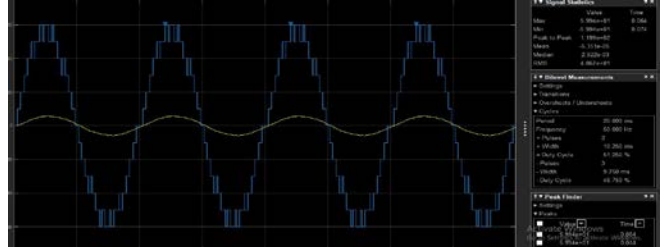

(ii) Phase Voltage & Current of 13-Level CHB MLI

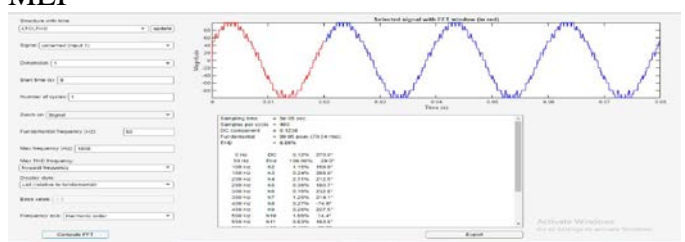

(iii) %THD & %Magnitude of 3rd, 5th, 7th & 9th of 13-Level CHB MLI

b) AM-MCLS-APOD Technique:-

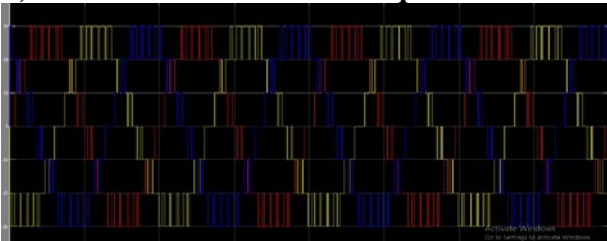

(i) Line Voltage of 7-Level CHB MLI

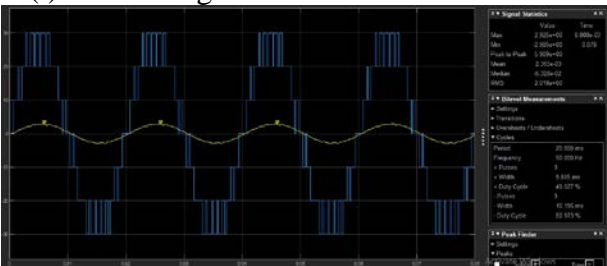

(ii) Phase Voltage & Current of 7-Level CHB MLI

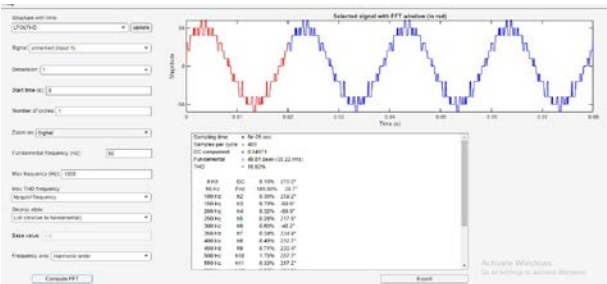

(iii) %THD & %Magnitude of 3rd, 5th, 7th & 9th of 7-Level CHB MLI

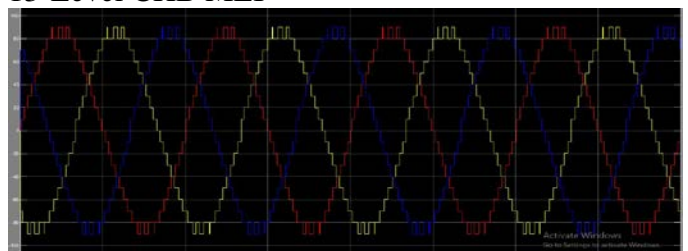

(i) Line Voltage of 19-Level CHB MLI

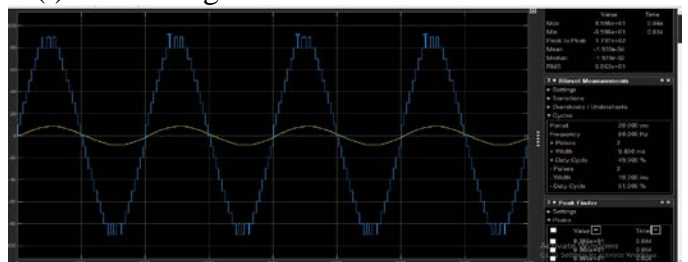

(ii) Phase Voltage & Current of 19-Level CHB MLI

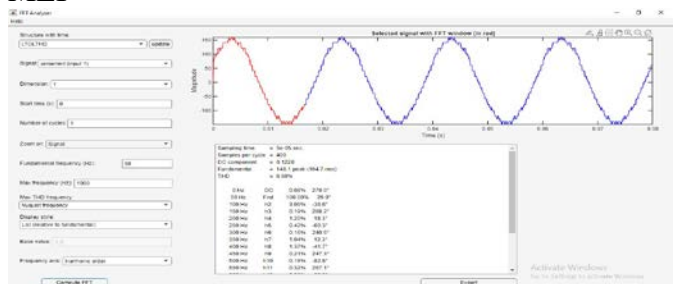

(iii) %THD & %Magnitude of 3rd, 5th, 7th & 9th of 19-Level CHB MLI

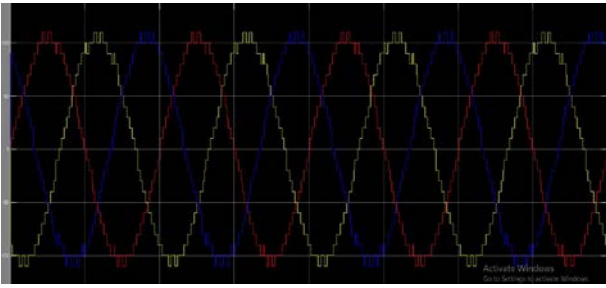

(i) Line Voltage of 23-Level CHB MLI

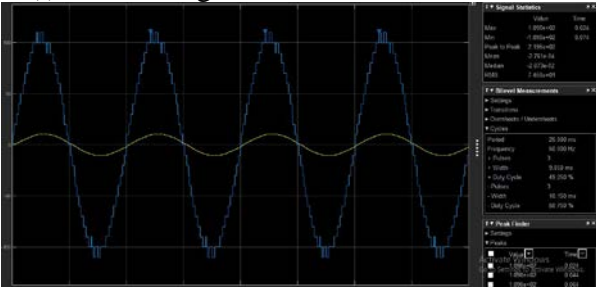

(ii) Phase Voltage & Current of 23-Level CHB MLI

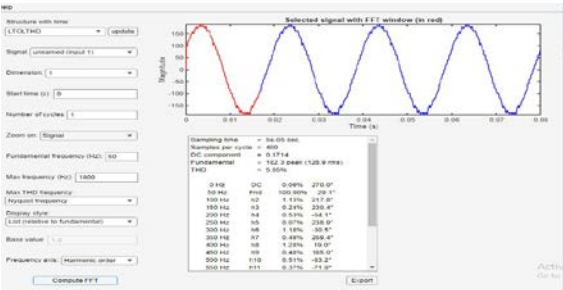

(iii) %THD & %Magnitude of 3rd, 5th, 7th & 9th of 23-Level CHB MLI

b) AM-MCLS-PO Technique:-

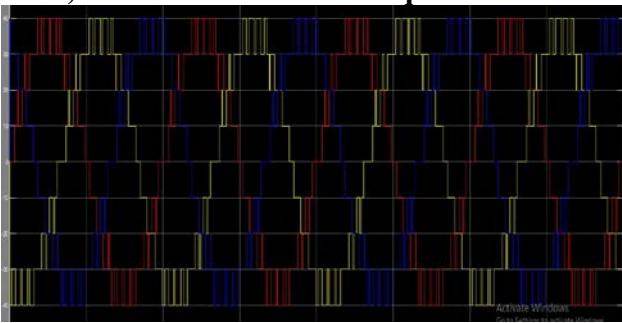

(i) Line Voltage of 9-Level CHB MLI

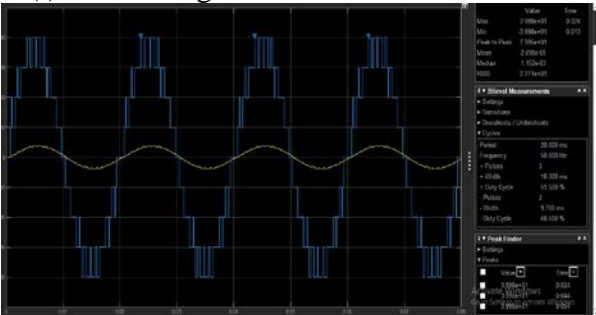

(ii) Phase Voltage & Current of 9-Level CHB MLI

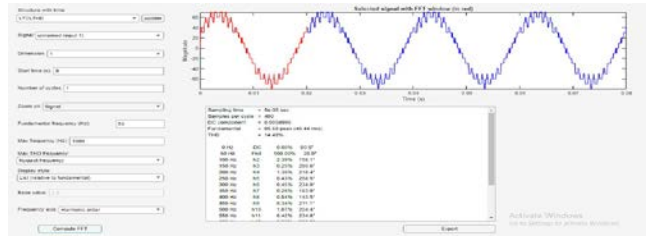

(iii) %THD & %Magnitude of 3rd, 5th, 7th & 9th of 9-Level CHB MLI

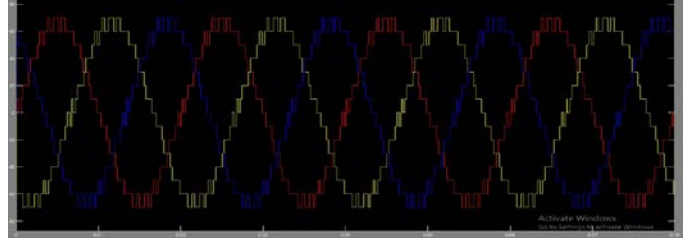

(i) Line Voltage of 15-Level CHB MLI

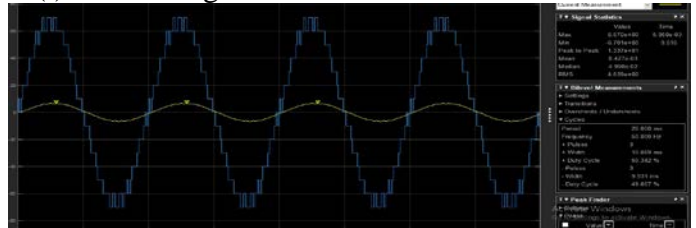

(ii) Phase Voltage & Current of 15-Level CHB MLI

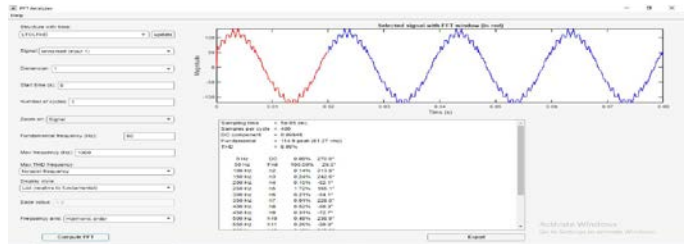

(iii) %THD & %Magnitude of 3rd, 5th, 7th & 9th of 15-Level CHB MLI

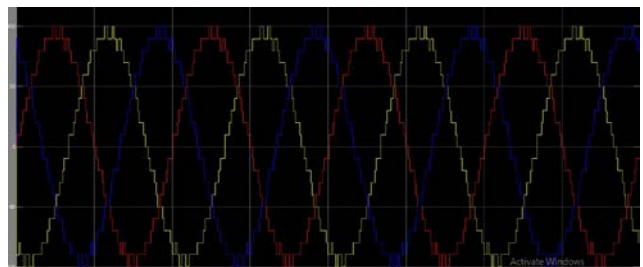

(i) Line Voltage of 21-Level CHB MLI

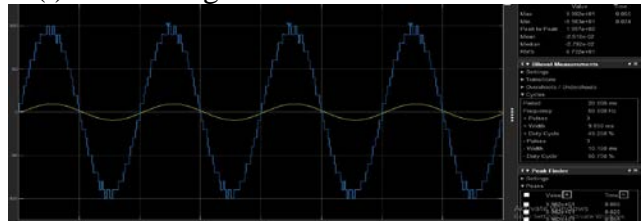

(ii) Phase Voltage & Current of 21-Level CHB MLI

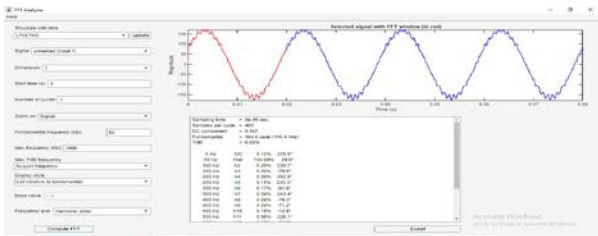

(iii)%THD & %Magnitude of 3rd,5th,7th & 9th of 21-Level CHB MLI

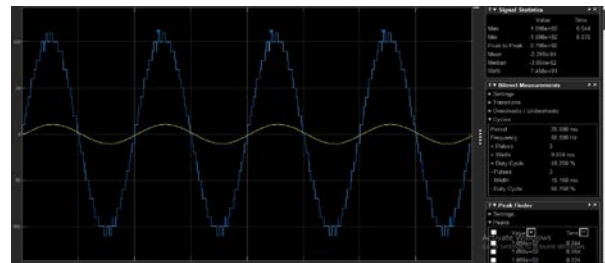

(ii)Phase Voltage & Current of 23-Level CHB MLI

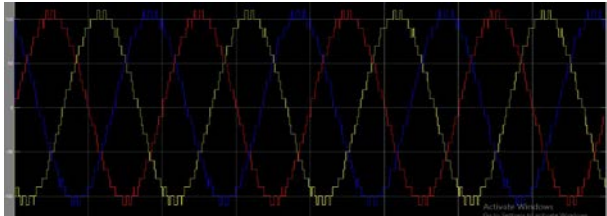

(i)Line Voltage of 23-Level CHB MLI

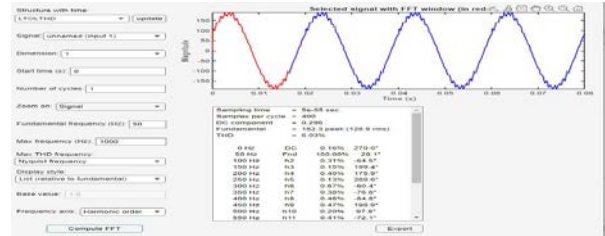

(iii)%THD & %Magnitude of 3rd,5th,7th & 9th of 23-Level CHB MLI

SIMULATION RESULTS:-

(i) Variation in % THD:-

3-Ø MLI Levels	AM-MCLS-PID		AM-MCLS-APOD		AM-MCLS-PO	
	%THD		%THD		%THD	
	L-L	L-N	L-L	L-N	L-L	L-N
3	37.11%	60.28%	47.28%	59.81%	47.28%	59.81%
5	17.38%	30.56%	27.67%	30.32%	26.16%	30.32%
7	11.36%	20.23%	16.92%	20.08%	18.18%	20.08%
9	9.06%	15.12%	12.90%	15.32%	14.49%	15.32%
11	7.55%	12.73%	10.24%	12.66%	12.04%	12.66%
13	6.67%	10.40%	8.86%	10.33%	9.98%	10.40%
15	6.49%	9.69%	9.03%	9.59%	8.99%	9.59%
17	6.18%	7.86%	7.40%	7.84%	7.81%	7.84%
19	5.28%	6.89%	6.80%	6.72%	6.96%	6.73%
21	4.89%	6.25%	5.64%	6.17%	6.58%	6.17%
23	4.64%	5.40%	5.65%	6.17%	6.03%	5.34%

(ii) Variation of V_{rms} & I_{rms} values per phase:-

MLI	AM-MCLS-PID		AM-MCLS-APOD		AM-MCLS-PO	
	V-RMS	I-RMS	V-RMS	I-RMS	V-RMS	I-RMS
3	7.746	6.579	7.742	6.600	7.742	6.600
5	1.397	1.321	1.397	1.324	1.397	1.323
7	2.080	2.017	2.080	2.018	2.080	2.018
9	2.711	2.650	2.711	2.655	2.711	2.655
11	3.381	3.310	3.381	3.315	3.381	3.315
13	4.067	3.998	4.067	4.000	4.060	3.990
15	4.711	4.638	4.711	4.641	4.711	4.630
17	5.414	5.332	5.414	5.333	5.414	5.331

19	6.142	6.033	6.063	5.983	6.063	5.981
21	6.729	6.645	6.732	6.648	6.732	6.651
23	7.458	7.349	7.450	7.351	7.450	7.350

(iii) %Magnitude 3rd, 5th & 9th Order Harmonics

(iv) :-

%Magnitude of Various Harmonics w.r.t Fundamental of Various AM-MCLS-PWM Techniques									
MLI	PID	APOD	PO	PID	APOD	PO	PID	APOD	PO
	3 rd	3 rd	3 rd	5 th	5 th	5 th	9 th	9 th	9 th
3	1.19%	0.69%	0.69	0.76%	0.74%	0.74%	1.57	1.08%	1.08%
5	0.36%	0.36%	0.46	0.92%	0.42%	0.27%	0.60	0.17%	0.25%
7	0.35%	0.70%	0.70	3.11%	0.28%	0.28%	0.33	0.71%	0.71%
9	0.13%	0.18%	0.25	0.15%	0.36%	0.43%	0.35	0.30%	0.34%
11	0.25%	0.34%	0.34	1.25%	0.26%	0.26%	0.08	0.25%	0.25%
13	0.21%	0.24%	0.24	0.70%	0.36%	0.48%	0.12	0.26%	0.35%
15	0.27%	0.20%	0.24	1.62%	1.74%	1.72%	0.35	0.27%	0.31%
17	0.44%	0.32%	0.32 %	1.01%	0.99%	0.99%	0.32	0.26%	0.26%
19	0.51%	0.19%	0.22	0.25%	0.42%	0.45%	0.13	0.21%	0.25%
21	0.19%	0.20%	0.20	0.09%	0.11%	0.11%	0.47	0.29%	0.29%
23	0.20%	0.24%	0.15	0.22%	0.07%	0.13%	0.43	0.48%	0.47%

(v) Variation of V_p & I_p:-

MLI	AM-MCLS-PID		AM-MCLS-APOD		AM-MCLS-PO	
	V _p	I _p	V _p	I _p	V _p	I _p
3	1.00	1.037	1.00	1.062	1.00	1.062
5	2.00	1.896	2.00	1.923	2.00	2.050
7	2.99	2.898	2.99	2.925	2.99	2.969
9	3.99	3.786	3.99	3.837	3.99	3.916
11	4.99	4.706	4.99	4.839	4.99	4.910
13	5.99	5.757	5.99	5.834	5.99	5.788
15	6.99	6.539	6.99	6.592	6.99	6.670
17	7.89	7.800	7.98	7.650	7.99	7.719
19	8.98	8.499	8.98	8.539	8.98	8.577
21	9.98	9.408	9.98	9.579	9.98	9.427
23	1.10	1.042	1.09	1.046	1.09	1.052

(vi) No. of Switching devices/phase:-

No. of Switching devices in all the AM-MCLS-PWM Techniques can be obtained by $D=4*[(N-1)/2]$

(vii) Cost:-

As the No. of levels increases the control circuits required for MLI operation

drastically increases which adversely increases the cost of the System.

VIII. Conclusion:-

In this paper, simplified method to generate simulation model for AM-MCLS-PWM techniques based on various carrier signals are presented. The AM-MCLS- PWM techniques for 3-Ø Symmetrical CHB MLI were analyzed

with a prevailing MATLAB/simulation tool and various parameters like %THD (a measure of closeness in shape between a wave form and its fundamental component), V_{rms} of fundamental have been evaluated, presented and analyzed. The simplified method is valid for N-Level generation and is validated from 3- \emptyset 3-Level MLI to 3- \emptyset 23-Level Symmetrical CHB MLI.

The variation of V_{rms} & I_{rms} & Peak voltage and peak currents are compared for 23-Level generation and are tabulated above.

Observation of the simulation results shows that the reduction in %THD from **37.11%** for 3- \emptyset 3-level CHB MLI to **4.64%** for 3- \emptyset 23-level by **AM-MCLS-PID** Technique, %THD of **47.28%** for 3- \emptyset 3-level CHB MLI to **5.65%** for 3- \emptyset 23-level by **AM-MCLS-APOD** Technique and reduction in %THD of **47.28%** for 3- \emptyset 3-level CHB MLI to **6.03%** for 3- \emptyset 23-level by **AM-MCLS-PO** Technique indicating that the produced voltage in the output is very much improved for 23-level CHB-MLI with **AM-MCLS-PID-PWM** technique with a reduced **%THD of 4.64%**. Hence, the AM-MCLS-PID modulation strategy provides the best line to line voltage along with least %THD profile among other AM-MCLS modulation techniques indicating the improved power quality.

In addition, with increased no. of levels from 3- \emptyset 3-Level to 3- \emptyset 23-level, the magnitude of 3rd harmonic content in the output is reduced drastically from 0.69% to 0.15% in AM-MCLS-PO PWM Technique, whereas the magnitude of 5th harmonic content in the output is reduced from 0.74% to 0.07% (Almost negligible/eliminated) & the magnitude of 9th harmonic content in the output is decreased from 1.57% to 0.43% in AM-MCLS-PID PWM Technique resulting that the lower order harmonics i.e., 3rd harmonics shall be eliminated by adopting AM-MCLS-PO PWM technique.

Thus, with the help of AM-MCLS-PID Modulation the line voltage is able to synthesize more levels compared to the phase voltage, thus resembling a more desirable sinusoidal waveform. Besides that, the line voltage yields better spectral performance, hence reducing the need of an output filter. The 3- \emptyset Symmetrical CHB MLI is also able to

produce line voltages with higher fundamental along with much lower THD% (as low as 4.64% w.r.t 23-Level) as compared to the single-phase CHB MLI.

From the analysis, it can also be concluded that, the AM-MCLS-PID scheme has advantages in 3- \emptyset applications due to the cancellation of the main carrier component between phase legs when the line voltages are formed. At high modulation index, the AM-MCLS-PID modulation strategy introduces the lowest line voltage THD%.

As a conclusion, the results suggested that the conversion efficiency of the converter mainly depends on the switching pattern selection. Since conduction losses depends on the number of switching devices in conduction mode and switching losses depends on the transition times which are indirectly depended on switching scheme selection. THD not only depends on number of switches in the circuit or no. of levels in the output but also depends on the switching scheme selection which can be clearly observed from the above results. Thus AM-MCLS- PID switching strategy provides the best line to line voltage & lower %THD profile among other multi carrier level shift and phase shifted modulation techniques.

(IX) Future Scope:-

The proposed CHB MLI are used for integration of Renewable Energy Sources, FACTS, HEVs, Power quality improvements etc.,. Now a days in order to meet the load demand the Distributed Generating Stations (DGS) are going to be installed at the load centers, where in most of the cases the electrical source is PV i.e., photo voltaic generation of solar power. With the integration of CHB's and with increased number of levels by appropriate switching scheme selection, the need of DC to DC boost converter which is required in normal operation can be completely eliminated resulting the system to be more economical.

Although this CHB MLI topology has been established in the market of medium-voltage & High power applications yet some aspects that require further development and research such as improving of efficiency, reducing switching losses, intelligent modularization & fault management.

References:-

[1]- Gurcharan Singh, Vijay Kumar Garg-"THD Analysis of Cascaded H-Bridge Multi-Level

Inverter”- 2017-4th IEEE International Conference on signal processing, computing & Control.

[2]- N. A Azli, Member IEEE and Y. C. Choong -“ Analysis on the Performance of a Three-phase Cascaded H-Bridge Multilevel Inverter”- 2006-First International Power and Energy Conference.

[3] J. D. van Wyk and F. C. Lee, “On a Future for Power Electronics,” IEEE J. Emerg. Sel. Top. Power Electron., vol. 1, no. 2, pp.59–72, 2013.

[4] Madhusudhan Pamujula, Amit Ohja, R.D.Kulkarni, Pankaj Swarnkar “Cascaded 'H' Bridge based Multilevel Inverter Topologies”-2020 International Conference for Emerging Technology.

[5]-Mariusz Malinowski, K.Gopakumar, Jose Rodriguez -“A Survey on Cascaded Multilevel Inverters”- 2010 IEEE Transactions on Industrial Electronics-Volume-57. Issue-7.

[6]- Jigneshkumar Patel, Vijay K. Sood-“Analysis of Symmetric and Asymmetric CHB-MLI Using MC based SPWM and THI-PWM”- 2020 IEEE- Electric Power and Energy Conference.

[7]- Deepa Sankar, C.A.Babu -“Cascaded H Bridge Multilevel Inverter Topologies for PV Application:A Comparison”- 2016 International Conference on Circuit, Power and Computing Technologies.

[8]- K.L.Dheeraj, M.Diwakar, M.DurgaRaj, M.Eswar, K.Naga Venkatesh-“THD Analysis of Cascaded MLI for Various PWM Techniques”-international journal of engineering trends And technology (IJETT)-Volume-11 number 3-May 2014.

[9]-Rekha Agrawal, Jitendra Kumar tandekar, Shailendra Jain-“Multi-Carrier Pulse Width modulation Schemes for Multilevel Converters”- 2016 IEEE Students' Conference on Electrical, Electronics and Computer Science.

[10]- Dr. Asha Gaikwad, Pallavi Appaso Arbune -“Study of Cascaded H-Bridge Multilevel Inverter”- 2016 2016 International Conference on Automatic Control and Dynamic Optimization Techniques.

[11]- Pratik Prajapatit, Meenakshi Jayaraman, Sreedevi V.T.-“ Harmonic Elimination in a Five Level Multilevel Inverter”- 2016 International Conference on Computer Communication and Informatics