



EMBEDDED WEB SERVER BASED INDUSTRIAL AUTOMATION FOR BOILER SYSTEM

¹Aamir. M. Parkar , ²Prof. S.I. Nipanikar

^[1] PG Scholar, E&TC Engineering, PVPIT Pune, Savitribai Phule Pune University, Pune, India.

^[2] Asst. Prof, E&TC Engineering, PVPIT Pune, Savitribai Phule Pune University , Pune ,India.

Email: ¹parkaraamir22@gmail.com , ²sanjaynipanikar@rediffmail.com

Abstract – This paper presents a design and prototype implementation of new industrial automation system that uses embedded web server technology which can be used to communicate with the system remotely. It introduces design of Embedded WEB server based on ARM 7 processor and Ethernet controller chip. In various internet application based on client/server architecture, it is better to use embedded web server rather than PC server for decreasing size, cost and power consumption. This Embedded WEB server can be used in various applications like industrial, agriculture and home automation. This paper proposes a review on remote monitoring and control of boiler plant parameters. The proposed system consists of two main components; the first part is the server (web server), which presents system core that manages, controls, and monitors industrial plant. Users and system administrator can locally (LAN) or remotely (internet) manages and control system by entering correct password.

Index Terms – Embedded Webserver, ARM 7, Ethernet controller

I. INTRODUCTION

Society in its daily life has become so dependent on automation that it is difficult to imagine life without automation engineering. Trade, environmental protection engineering, agriculture, building engineering, and medical engineering are some of the areas where automation is playing a prominent role. In the past, automation engineering was mainly understood as control engineering dealing with a number of electrical and electronic

components. This picture has changed since computers and software have made their way into every component and element of communications and automation. Data acquisition systems with remote accessibility are in great demand in industry and consumer applications. With the ability to access the application remotely, corporation can eliminate the need to send a service person to the application and thus save the labor time and money. A web server provides access to the end devices for the client by uploading web pages as per the client request. When the configured IP address is enter in the web browser, the predesigned HTML web pages gets displayed through which the client can remotely monitored the sensor status respectively. ARM7 processor is the main controller of web server, ARM Processor is chosen because ARM has high data processing capability.

II. LITERATURE REVIEW STAGE

A deep and profound literature survey is backbone of any successful project. Extensively search has been carried out for past and related work in this field. Internet tool is used as source of information for carrying out this literature survey.

(1) “Embedded Web Server for Home Appliances”, IJERA, Mar’12 by Mr. Abhishek Vichare and Ms. Shilpa Verma:

Main aim of this paper is to describe how to connect a micro- controller to LAN or Internet and use it as a web server. This paper offers a new approach to control home appliances from a remote terminal, with an option from a local server, using the Internet. The system is designed to control home appliances' on/off, to regulate their output power, and to set their

usage timing. The microcontroller which is used in this project is the Philips P89C51RD2BN microcontroller.

(2) "ARM Embedded Web Server Based on DAC System", 2011 IEEE by M Poongothai:

This paper describes the principles to design a system for Internet-based data-acquisition system and control by using Advanced RISC Machine (ARM7/9) processor and in-build web server application with General Packet Radio Service (GPRS) technology. The main core of the system is an embedded hardware running on a NUT OS, an industrial grade RTOS for hard time applications.

(3) "Design and Implementation of an Embedded Webserver Based on ARM", 2010 IEEE by Mo Guan and Minghai Gu:

In this paper, the embedded web server, which take Samsung Corporation's ARM9-S3C2440AL processor as core is designed, its operating system is Linux, and the system hardware architecture is presented.

(4) "ARM microcontroller based Wireless Industrial Automation System", IJAREEIE, Vol. 3, Special Issue 4, April 2014 by Nagisetty Sasidhar and Monica P. Suresh:

Design and implementation of ARM Micro controller based wireless industrial automation system is discussed in this paper. It collects the information from all sensor modules and provides that information to the end user through TCP/IP network. The sensor module is an ARM microcontroller for monitoring and controlling the various parameters of a plant.

III. PROPOSED SYSTEM

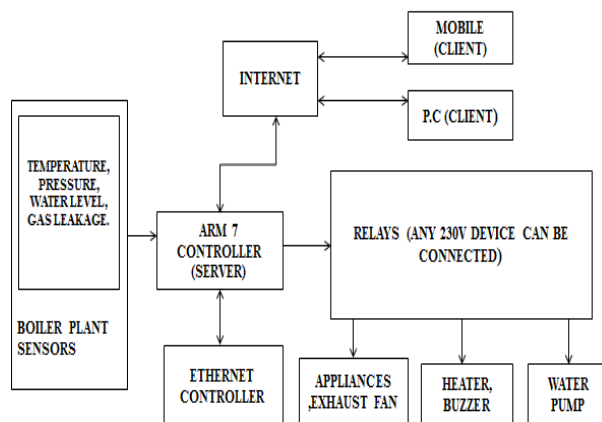

Figure 1: Block Diagram of proposed system. Block diagram of embedded webserver based industrial automation for boiler system is shown in Fig 1. ARM7 is the main micro-controller of the system. The sensory network is to the

ARM7. ARM 7 acts as the server of the system. The admin can monitor and control the devices by sending commands to controller through the server by opening the web page, and the controller will send and receive the signals from the sensors and relays. The sensors are pressure sensor, temperature sensor, water level sensor, gas leakage sensor which is used to monitor various parameters of the boiler plant. The server can be accessed from anywhere if internet connection is available. All the real time data from the various sensors and modules will be updated in the server continuously. Thus the user can monitor his industry from anywhere and can control the plant and various machines remotely. The system consists of Ethernet controller chip which handles all the requests of various clients.

IV. HARDWARE DESCRIPTION

The general hardware structure is shown below. Each I/O channel can select various signals like voltage, resistance, current. This signals from the sensors is given to ARM 7 LPC2148 and then to inbuilt ADC for A/D conversion. The digitized data is stored in the memory. This data is accessed through web server by entering the correct IP address given to the system. ARM 7 has inbuilt SPI module which directly support the Ethernet communication.

The System has Ethernet controller IC which handles most of the network protocol requests. The Ethernet controller communicates directly to the LPC2148 controller using a standard SPI interface. The system hardware consists of Ethernet controller ENC28J60, RJ45 socket, Ethernet transformer, LPC2148 controller and input/output devices like sensors and appliances.

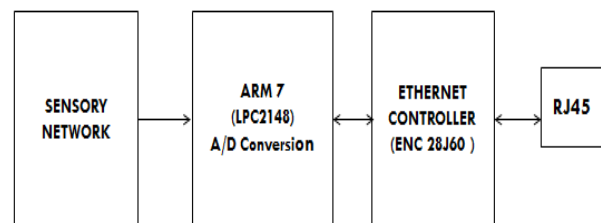

Figure 2: General hardware structure

A) Temperature sensor :

For temperature measurement PT100 sensor is used. This sensor can detect temperature of range from -200 °C to +850°C. The temperature coefficient of the sensor is 0.0039 Ω/ °C. PT100

uses platinum as a metal, whose resistance changes depending on the temperature to which it is exposed. The change in resistance for every 1 °C is 0.384 Ω.

RTD (PT100) measurement Consideration:

- 1) For excitation of RTD 1 ma current source is used.
- 2) ADC is 10 bit Successive approximation type.
With reference voltage 2.5V
- 3) Resolution = Reference voltage / Full scale count
= 2.5 / 1023
= 2.4 mv

Table 1: Temperature measurement chart

Input in Degree Celsius	Expected Count in Degree Celsius	Resistance (ohm)	1 mA x Res (Volt)	Apply Gain By Hardware and removing offset (Volt)	ADC Count	After calibration user count in Degree Celsius
0	0	100	0.1	0	0	0
30	30	111.67	0.11167	0.25933	106.1192	30
60	60	123.24	0.12324	0.51644	211.329067	60
90	90	134.71	0.13471	0.77133	315.6296	90
120	120	146.07	0.14607	1.02378	418.929867	120
150	150	157.33	0.15733	1.274	521.3208	150
180	180	168.48	0.16848	1.52178	622.711467	180
210	210	179.53	0.17953	1.76733	723.1928	210
240	240	190.47	0.19047	2.01044	822.673867	240
270	270	201.31	0.20131	2.25133	921.2456	270
300	300	212.5	0.2125	2.5	1023	300

B) Pressure sensor:

The pressure transmitter is used as a pressure sensor to measure the pressure of steam of the boiler. The pressure sensor used is SPD 005G. It can detect pressure range from 0-35000 Pa.

C) Water level sensor:

For detection of water level 3 probes are used. The probes are used to detect 3 levels namely low, medium and high level of water. If the water level is empty then the water pump is switched on automatically. When the water is full the 3 probes are shorted and it triggers to switch of the water pump.

D) Gas leakage sensor:

MQ2 sensor is used to detect the gas leakage of boiler rooms. MQ-2 gas sensor has high sensitivity to LPG, Propane and Hydrogen, also could be used to Methane and other combustible steam, it is with low cost and suitable for different application. In this system if gas leakage is detected then the exhaust fan and buzzer are switched on to prevent from hazardous condition.

E) Ethernet controller:

The ENC28J60 is an Ethernet Controller chip used in this system. It is an industry standard serial peripheral interface (SPI). It is an Ethernet network interface for any controller equipped with SPI. The ENC28J60 meets all the IEEE 802.3 specification.

V. BOILER

A boiler or steam generator is a device used to create steam by applying heat energy to water. A boiler is a closed vessel in which water or other fluid is heated. The fluid does not necessarily boil. A steam boiler produces steam for a laboratory-scale chemical pulping process. The process uses fuel oil and includes the water storage tank, boiler, and pipelines. The feed water temperature is approximately 20 °C and after the boiler, the steam temperature is approximately 200 °C.

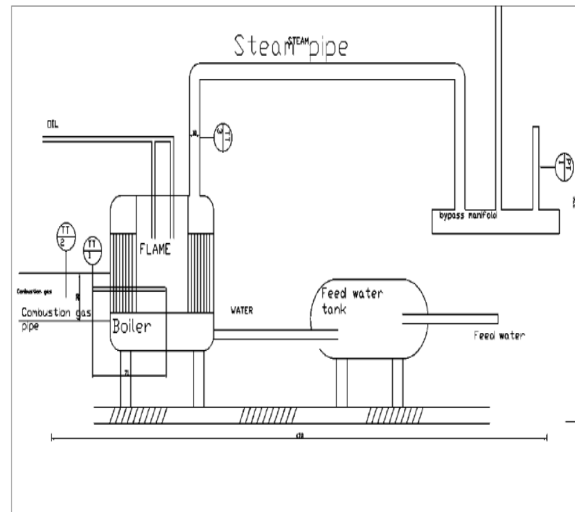

Figure 3: A general steam boiler

There are four measurements implemented: three for the temperature and one for the steam pressure. Figure shows the measurement locations.

- 1) The temperature is measured from the flame in the combustion chamber (the required measuring range from the room temperature to approximately 1500 °C)
- 2) The temperature from the combustion gas pipe (from the room temperature to over 300 °C)
- 3) The temperature from the surface of the steam pipe (from the room temperature to approximately 300 °C).
- 4) The pressure, which normally is approximately 13 bars, is measured from the bypass manifold.

During shutdowns and maintenance operations, however, the pressure may vary between 0-40 bars.

VI. WEB SERVER TECHNOLOGY

Embedded web server refers to a Web Server to monitor and control the system which remotely in the support of appropriate hardware platforms and software systems. It transfers monitor and control equipment into an internet based web page, possessed with TCP/IP protocol as the communication protocol and Web server technology as its core. An embedded web server is a HTTP protocol stack that is meant for handling HTTP requests. The protocol used for the communication between web server and web browser is Hyper Text Transfer Protocol or HTTP protocol. This protocol defines all the basic frame work of web communications by handling requests and also by providing control information to be transferred between browser and server. To obtain a web page, the browser and server should establish a connection at Port 80. The Internet protocol suite is the computer networking model and set of communications protocols used on the Internet and similar computer networks. It is commonly known as TCP/IP, because it's most important protocols, the Transmission Control Protocol (TCP) and the Internet Protocol (IP). TCP/IP provides end-to-end connectivity specifying how data should be packetized, addressed, transmitted, routed and received at the destination. A web server provides access to the client by uploading web pages as per request of the clients. When the configured IP address is entered in the browser, the client can monitor the various parameters of the system. Client can select the device status and can control the devices by toggling the switches on the browser.

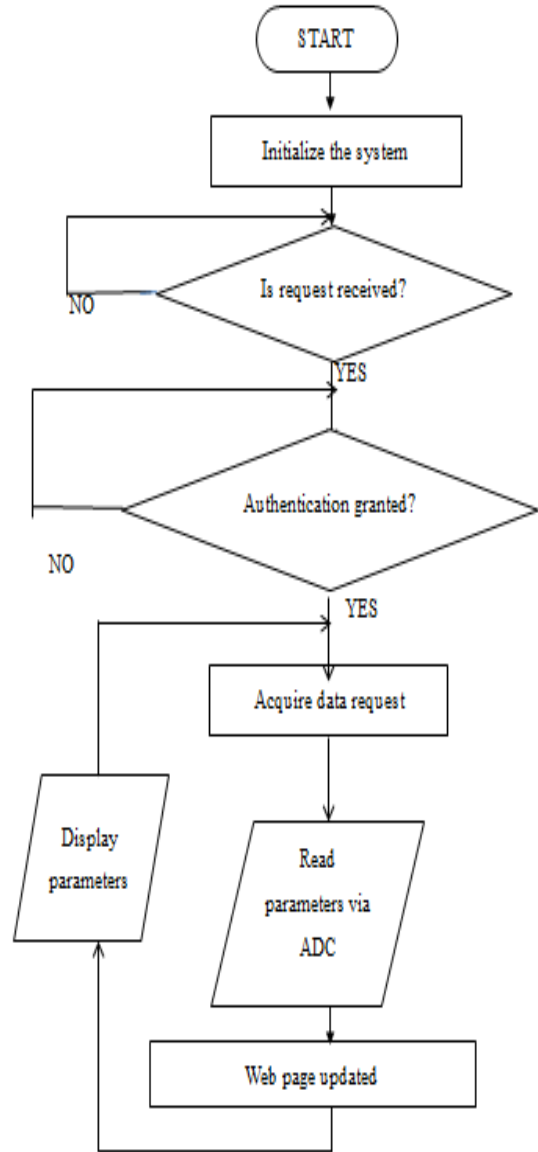

Figure 4: Flowchart for monitoring the system

VII. FLOW CHART

A) Monitoring:

B) Controlling:

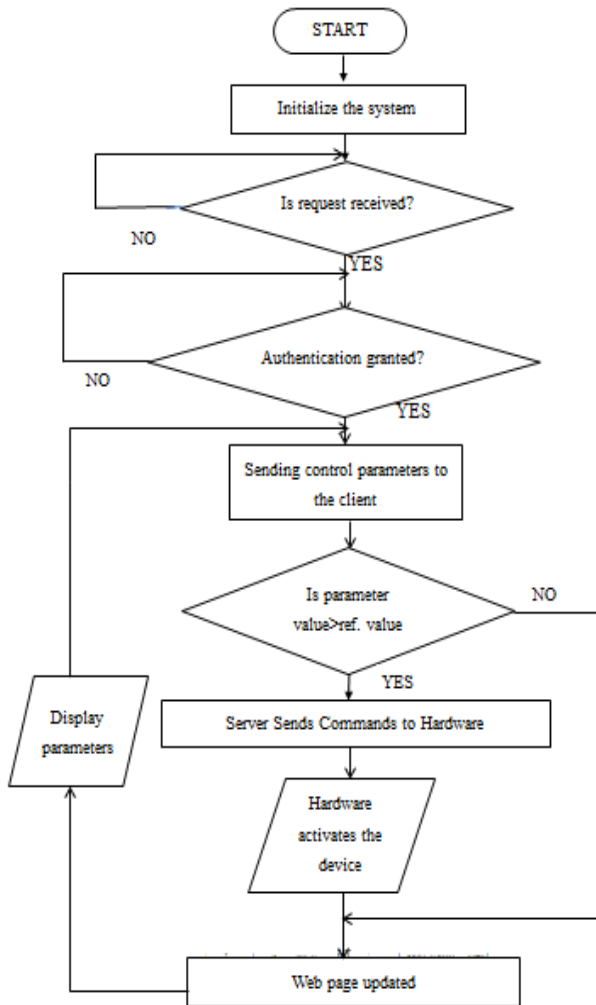

Figure 5: Flowchart for controlling the system

VIII. WORKING MODEL AND TEST RESULTS

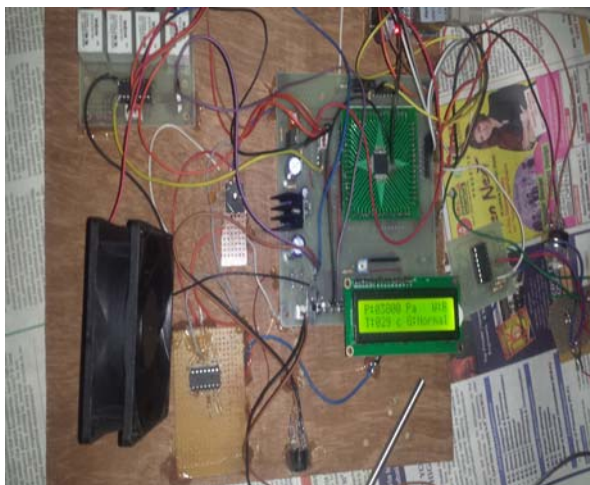

Figure 6: Complete setup of the system

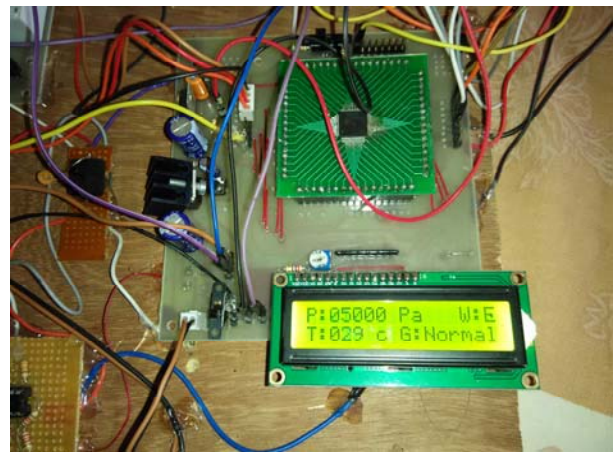

Figure 7: LCD Display of Pressure (P), Temperature (T), Water level (W), Gas leakage (G).

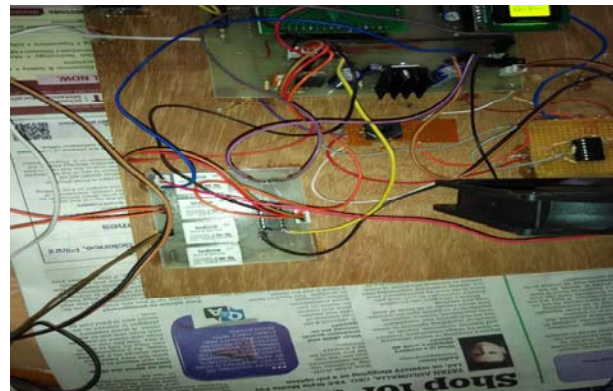

Figure 8: Devices connected to relay circuit

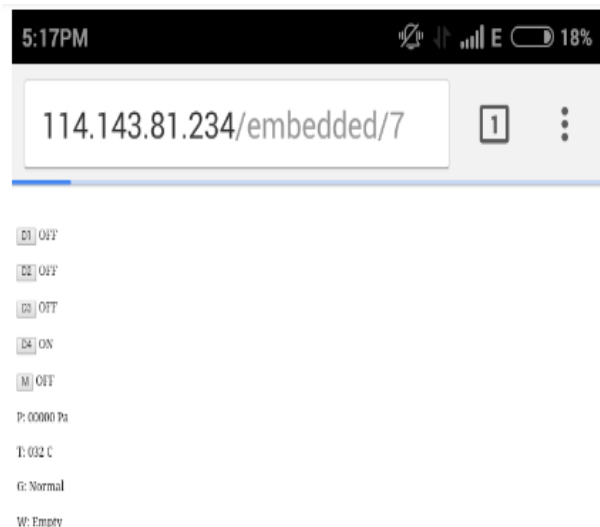

Figure 9: Designed web page of system opened in browser

IX. CONCLUSION

The system is used to monitor boiler parameters remotely such as temperature, pressure, water level and gas leakage.

These parameters are monitored from anywhere through internet. The system is implemented using ARM 7 processor and Ethernet controller. The sensors used in the system can match the actual boiler specifications.

X. ACKNOWLEDGEMENT

I would like to acknowledge all the people who have of the helped and assisted me throughout my analysis of project work. It gives me a great pleasure in bringing out the project work entitled, “EMBEDDED WEB SERVER BASED INDUSTRIAL AUTOMATION FOR BOILER SYSTEM

”. It is observed outcome of the exciting work, done under the inspiring guidance of my guide Prof. S.I.Nipanikar.

XI. REFERENCES

- [1] Mr. Abhishek Vichare, Ms. Shilpa Verma “Embedded Web Server for Home Appliances”, International Journal of Engineering Research and Applications (IJERA) ISSN: 2248-9622 National Conference on Emerging Trends in Engineering & Technology (VNCET-30 Mar’12).
- [2] M Poongothai “ARM Embedded Web Server Based on DAC System” ,IEEE, 2011.
- [3] Mo Guan and Minghai Gu “Design and Implementation of an Embedded Webserver Based on ARM”, 2010 IEEE Mr. Vijay Bhamrae & Mr. Chirinjeevi “CAN based real time implementation in automobile using ARM” (IJARCET) Volume 2, Issue 3, March 2013
- [4] Nagisetty Sasidhar and Monica P. Suresh. “ARM microcontroller based Wireless Industrial Automation System”, International Journal of Advanced Research in Electrical, Electronics and Instrumentation Engineering (An ISO 3297: 2007 Certified Organization) Vol. 3, Special Issue 4, April 2014.
- [5] Sushma M. Gawali, Snehal M. Gajbhiye “Design of ARM based Embedded Web Server for Agricultural Application”,

International Journal of Computer Science and Information Technologies (IJCSIT), Vol. 5 (1), 2014.

- [6] Marko Paavola and Kauko Leiviskä, “Wireless Sensor Networks in Industrial Automation”, Intech, Mar-2010.