



# PERFORMANCE IMPROVEMENT BY OPTIMAL LOCATION AND DAMPING OF OSCILLATIONS IN THE POWER SYSTEM USING TCSC

<sup>1</sup>Shrirang Kulkarni, <sup>2</sup>T.N.Venkataraman

<sup>1</sup>PG Student, <sup>2</sup>Asst professor

EEE Dept, Dayanand sagar college of engg Bangalore

Email: <sup>1</sup>shrirangbe@gmail.com, <sup>2</sup>tnv.dsce@gmail.com

**Abstract—** TCSC increases the performance of system by decreasing reactance of line and hence increases the power flow in the line as well as reduces the line losses. Optimal location for placing of TCSC is found by performance indices calculation to reduce overloading of each transmission line in normal case and contingency cases. Power oscillations can be damped. 7 bus system is used to carry out simulation through MATLAB SIMULINK.

**Index Terms—** FACTS, TCSC.

## I. INTRODUCTION

In present days, Power demand is increasing every year, to meet this demand the expansion of power generation and transmission is necessary. But at the same time it is limited due to limited resources and environmental restrictions. , installation of new transmission lines with the large interconnected power system are limited to some of the factors like economic cost, environment related issues. As a consequence some transmission lines are heavily loaded. The proposed concept is power electronics based technology has been mainly used for solving various power system control problems.

Continuous and fast improvement of power electronics technology has made FACTS (Flexible AC Transmission system) a promising concept for power system development in the coming decade. Among a variety of FACTS devices, Thyristor controlled series compensator

(TCSC) is chosen and well designed to enhance the transient stability of the power system.

TCSC increases the performance of system decreasing reactance of line and hence increases the power flow in the line but cost of FACTS device is high. An approach to determine the most suitable location for placing the TCSC in order to enhance the

Power flow in transmission line using contingencies analysis and ranking. So it is required to find optima location of FACTS device. Performance indices are defined and ranked to place TCSC in line which informs to locate TCSC in better position.

Paper deals with the modelling and simulation of TCSC for three machine seven bus system. Simulink models are developed for case study systems with and without TCSC.. The complete digital simulations are performed in the MATLAB/SIMULINK environment to provide comprehensive understanding of the issue. Section 2 gives information about TCSC model .section 3 introduces the performance indices and ranking process. Result and discussions are carried out in section 4.

II. TCSC MODEL

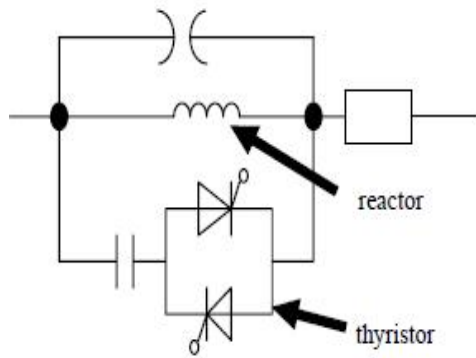

Fig.1 TCSC (Thyristor controlled series compensator)model

Fig 1 of TCSC consists of three main components: Capacitor bank, bypass inductor and bidirectional thyristors SCR1 and SCR2. Characteristics of TCSC placed in a transmission network provides the power flow control in a power system improving the damping power oscillation and reduces the net loss providing voltage support. It can be represented as variable reactance.

The thyristors in TCSC device offers a flexible adjustment with the ability to control the continuous line compensation. TCSC controllers effectively used for solving power system problems of transient stability, dynamic stability, steady state stability and voltage stability in long transmission lines. Transmission lines are represented as pi-equivalent parameters in simulation

In this paper it is designed based on the thyristor based FACTS technology that has the ability to control the line impedance with a thyristor-controlled capacitor placed in series with the transmission line. It is used to increase the transmission line capability by installing a series capacitor that reduces the net series impedance thus allowing additional power to be transferred. The effect of TCSC on the network can be seen as controllable reactance in line that compensates the reactance of line.

III. PERFORMANCE INDICES CALCULATION

The optimal locations to install the FACTS devices for secured Power flow under normal

and contingency condition are presented in this section. The overload on the transmission line is eliminated by placing TCSC in the appropriate location.

Active power performance index (Pip) is introduced in this section for installing TCSC at suitable location to achieve secured power flow under normal operating condition. The essential idea of TCSC placement in the proposed methodology is to determine a line, which is most suitable for eliminating the overloads on the transmission lines

a) Active power performance index (Pip)

$$PIp = [(Pi/P_{max})^{2n}] \tag{1}$$

Where Pi=Active power flow in line i.

P<sub>max</sub>=Maximum power flow in line i  
n=specified exponent (Here value of n is kept unity)

L=total number of transmission lines in the system

Maximum power transfer can be expressed by formula

$$P_{max} = Vi * Vj / X \tag{2}$$

Where Vi=Voltage at bus i obtained from power flow  
Vj=Voltage at bus j obtained from power flow  
X=Reactance of line connecting bus i and bus j

Pip value is calculated for all the lines .the line with least positive value is considered and ranked first. next least valued is second and so. TCSC is placed on line having rank 1 .

b) Contingency capacity Performance index (CPI)

Contingency capacity Performance index (CPI) is introduced in this section for installing TCSC at suitable location to achieve secured power flow under contingency condition. Contingency capacity performance index is calculated as follows

$$CPI = [(P_{max} - Pi) / P_{max}] \tag{3}$$

Where P<sub>max</sub> =Maximum power flow in line i

Pi=Active power flow in line i

CPI value is calculated for all the lines .the line with highest positive value is considered and ranked first. next highest valued is second and so.TCSC is placed on line having rank 1

IV. RESULTS AND DISCUSSIONS

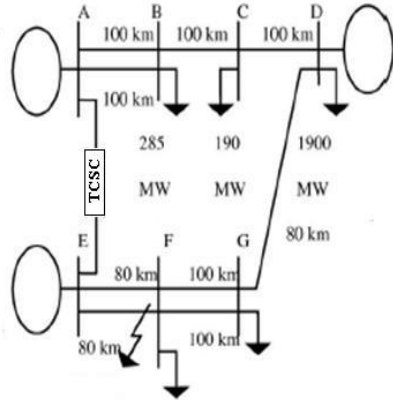

Fig 2.Three machine 7 bus system test system

Fig 2 is the three machine 7 bus system test system is considered for case study.Consists of 3 machines ,7 buses, 5 loads and 10 transmission lines.Test system is simulated in Matlab simulink for 5 seconds.

TABLE I

Line data without TCSC under normal condition

| Line no         | Power      |            | Loss     |           | %loading   |
|-----------------|------------|------------|----------|-----------|------------|
|                 | MW         | Mvar       | MW       | Mvar      |            |
| L1 (A-B)        | 385        | 79         | 5        | -5        | 96.12      |
| <b>L2 (B-C)</b> | <b>484</b> | <b>138</b> | <b>8</b> | <b>38</b> | <b>126</b> |
| L3 (C-D)        | 381        | 79         | 5        | 2         | 95         |
| L4 (D-G)        | 355        | -25        | 1        | 21        | 88.75      |
| L5 (G-F)        | 234        | 46         | 3        | 7         | 58.5       |
| L6 (G-F)        | 234        | 46         | 3        | 7         | 58.5       |
| L7 (F-E)        | 279        | 54         | 12       | 1         | 70         |

|           |     |    |    |    |       |
|-----------|-----|----|----|----|-------|
| L8 (F-E)  | 279 | 54 | 12 | 1  | 70    |
| L9 (E-A)  | 159 | 98 | 4  | 3  | 39.7  |
| L10 (A-B) | 385 | 79 | 5  | -5 | 96.12 |

From table I it is observed that transmission line number 2(L2) is overloaded at 126%.The main objective of TCSC is for power flow control such that overloading of the line is brought to approximately 125% or so. Suitable location for TCSC is identified based on values of performance indices calculated.

TABLE II

Ranking based on Active power performance index

| Line No | Pip    | Ranking |
|---------|--------|---------|
| L1      | 0.9264 | 9       |
| L2      | 1.46   | 10      |
| L3      | 0.9072 | 7       |
| L4      | 0.7876 | 6       |
| L5      | 0.342  | 2       |
| L6      | 0.342  | 3       |
| L7      | 0.4865 | 4       |
| L8      | 0.4865 | 5       |
| L9      | 0.15   | 1       |
| L10     | 0.9264 | 8       |

TABLE III

Test system data with TCSC under normal condition

| Line No | Power |      | Loss |      | %loading |
|---------|-------|------|------|------|----------|
|         | MW    | Mvar | MW   | Mvar |          |
| L1      | 385   | 79   | 5    | -5   | 96.12    |
| L2      | 484   | 138  | 8    | 38   | 126      |
| L3      | 381   | 79   | 5    | 2    | 95       |
| L4      | 355   | -25  | 1    | 21   | 88.75    |
| L5      | 234   | 46   | 3    | 7    | 58.5     |
| L6      | 234   | 46   | 3    | 7    | 58.5     |
| L7      | 279   | 54   | 12   | 1    | 70       |

|           |            |           |          |          |              |
|-----------|------------|-----------|----------|----------|--------------|
| L1        | 299        | 21        | 3        | 4        | 74.75        |
| <b>L2</b> | <b>327</b> | <b>51</b> | <b>3</b> | <b>3</b> | <b>81.75</b> |
| L3        | 228        | 47.4      | 2        | 10       | 57           |
| L4        | 205        | 59        | 2        | 7.2      | 51.25        |
| L5        | 332        | 71.4      | 7        | 8        | 83           |
| L6        | 332        | 71.4      | 7        | 8        | 83           |
| L7        | 386.4      | 96.2      | 4        | 4        | 96.5         |
| L8        | 386.4      | 96.2      | 4        | 4        | 96.5         |
| L9        | 380        | 78.5      | 5        | 10       | 95           |
| L10       | 299        | 21        | 3        | 4        | 74.75        |

Line 9(L9) is having Pip value 0.15 so ranked first. From Table III provides optimal solution for optimal placement of TCSC in line L9 (rank 1) decreases the overloading to 81.75 %.which is exempted upto120%.Other line are also having %overloading within limit

TABLE IV

Line data without TCSC under contingency condition

| Line No   | Power      |            | Loss      |           | %loading     |
|-----------|------------|------------|-----------|-----------|--------------|
|           | MW         | Mvar       | MW        | Mvar      |              |
| <b>L1</b> | <b>674</b> | <b>190</b> | <b>16</b> | <b>97</b> | <b>168.5</b> |
| L2        | 397.4      | 93.61      | 6         | 22        | 99.35        |
| L3        | 300        | 75         | 3         | 1.8       | 75           |
| L4        | 379.47     | -9         | 1         | -5.38     | 94.75        |
| L5        | 248.9      | 50.5       | 3         | 4         | 62.2         |
| L6        | 248.9      | 50.5       | 3         | 4         | 62.          |
| L7        | 295.7      | 57.5       | 3         | 1.1       | 73.9         |

|    |       |       |   |     |      |
|----|-------|-------|---|-----|------|
| L8 | 295.7 | 57.5  | 3 | 1.1 | 73.9 |
| L9 | 190   | 103.8 | 5 | 97  | 47.5 |

Contingency created by taking out the Line L10. From table IV it is observed that transmission line number 1(L1) is overloaded at 168%.under contingency condition.

Line 9(L9) is having CPI value 0.525 which is the highest positive value so ranked first TCSC placed in that line to reduce overload.

TABLE V

Ranking based on contingency performance index

| Line No | CPI    | Ranking |
|---------|--------|---------|
| L1      | -0.685 |         |
| L2      | 0.0065 | 8       |
| L3      | 0.250  | 6       |
| L4      | 0.051  | 7       |
| L5      | 0.3775 | 2       |
| L6      | 0.3775 | 3       |
| L7      | 0.260  | 4       |
| L8      | 0.260  | 5       |
| L9      | 0.525  | 1       |

TABLE VI

Line data with TCSC under contingency condition

| Line No   | Power        |             | Loss     |           | %loading     |
|-----------|--------------|-------------|----------|-----------|--------------|
|           | MW           | Mvar        | MW       | Mvar      |              |
| <b>L1</b> | <b>497.2</b> | <b>59.8</b> | <b>8</b> | <b>69</b> | <b>124.3</b> |
| L2        | 234.2        | 20.1        | 1.5      | 16        | 58.6         |

|    |       |       |      |    |        |
|----|-------|-------|------|----|--------|
| L3 | 139   | 36    | 0.72 | 25 | 34.75  |
| L4 | 280   | 8.7   | 3    | 5  | 70     |
| L5 | 370.7 | 77    | 6    | 13 | 92.67  |
| L6 | 370.7 | 77    | 6    | 13 | 92.67  |
| L7 | 425   | 106.1 | 6    | 17 | 106.25 |
| L8 | 425   | 106.1 | 6    | 17 | 106.25 |
| L9 | 496.9 | -150  | 3    | 7  | 124    |

From the above Table VI it is observed that with optimal location of TCSC in line L9 decreases the overloading to 124 %.which is exempted upto125%.Other line are also having %overloading within limit.

**V. POWER OSCILLATION DAMPING**

Power oscillating damping is the big issue when we dealing with dynamic stability of system. To reduce the oscillations generated due to many reasons like overload in the line, loss of lines and loss of generating units etc. We should use some controlling methods to reduce damping. In this thesis POD (Power oscillating controller) is used, which effectively decreases the oscillations.

Power flow of test system is studied and oscillations are observed which are shown in fig3. oscillations are damped or minimized using damping controller shown in fig3 .In Fig 4 Active power flow is shown where oscillations are damped or reduced up to 0.3seconds.

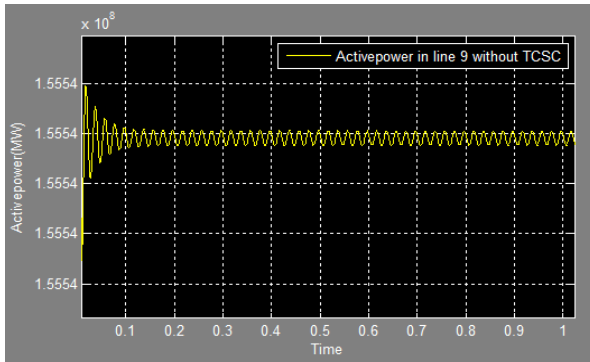

Fig 4 Active power flow in line 9 with TCSC

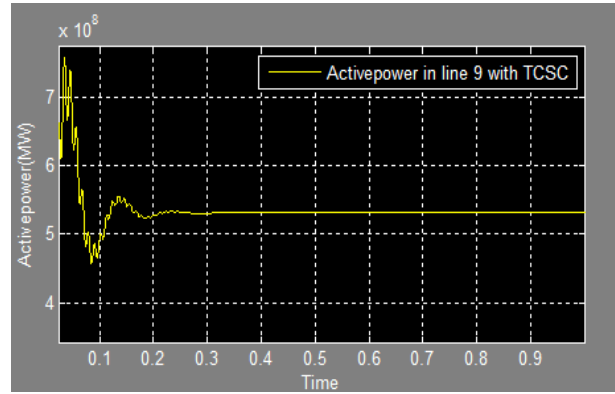

Fig 4 Active power flow in line 9 with TCSC

Oscillations of line 1 is observed and decreased which are shown in fig 5 and fig6

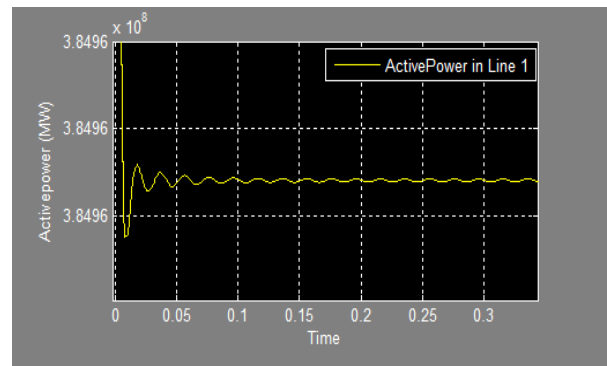

Fig 5 Active power flow in line 1 without TCSC

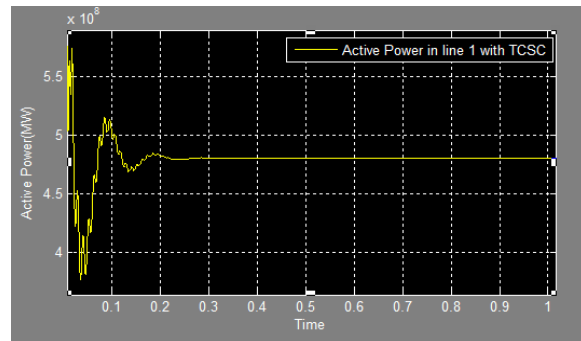

Fig 6 Active power flow in line 1 with TCSC

**VI. CONCLUSION**

As per the objective study of paper, the simulation result shows that the effective placement of FACTS device TCSC in optimal location of the transmission line based on performance indices decreases the overloading of line under Normal operating condition and contingency condition. The TCSC changes the real and reactive power of the system in any location, but the optimal location presents the best benefit on power losses. Power oscillations are damped using

controller. TCSCs effectiveness for loss minimization is verified and tabulated.

**REFERENCES**

- [1] Narain G.Hingorani and Laszlo Gyugyi "Understanding FACTS Concepts and technology of flexible AC transmission systems" edition 2000.
- [2] K.R.Padiyar, "FACTS Controllers in Power Transmission and Distribution", 2013
- [3] K shanmukhsundar; H.M.ravikumar "Selection of TCSC location for secured optimal power flow under normal and network contingencies", Science direct (Elsevier), Electric Power Research 34(2012) 29–37.
- [4] X.Y. Li "Nonlinear controller design of thyristor controlled series compensation for damping inter-area power oscillation", Science direct (Elsevier), Electric Power Research 76 (2006) 1040–1046.