



# SMART ANTENNA AND RFID TECHNOLOGY ENABLED WIRELESS CHARGER FOR MOBILE PHONE BATTERIES

N.Balakumar<sup>1</sup>, Dr. S.R.Boselin Prabhu<sup>2</sup>

<sup>1</sup>Assistant Professor, Department of Electrical and Electronics Engineering,  
Tamilnadu College of Engineering, Coimbatore, Tamilnadu, India.

<sup>2</sup>Associate Professor, Department of Electronics and Communication Engineering,  
V.S.B Engineering College, Tamilnadu, India.

## Abstract

**Now a days that everyone has a mobile phone. Whether it is for business purposes or personal use, need an effective way of charging the battery in the mobile phone. Though like most people, it possibly don't like being tethered to the wall. Imagine a system where our mobile phone battery is always charged. No more worrying about forgetting to charge the battery. It is the motivation of this paper to converse the first step toward realizing this goal. A system will be offered using existing antenna and RFID technology to charge a mobile phone battery without using wires. In this first step, it will use a standard phones, and combine the charging technology into a commercially available base station. The base station will contain an antenna tuned to 915MHz and a charge pump. In this paper to discuss about the advantages and disadvantages of such a system, and hopefully pave the way for a system incorporated into the phone for charging without the use of a base station.**

**Keywords: RFID, Smart Antenna, Wireless charger, Cellular Technology and RF system.**

## 1. INTRODUCTION

Cellular telephone technology became commercially available in the market of 1980's. When the mobile phone was first employed, it was huge in size by today's standards. This

reason is two-fold, the battery had to be large, and the circuits themselves were large. Through the years, technology has permitted the mobile phone to shrink not only the size of the ICs, but also the batteries. However, still have one of the original problems, it must plug the phone into the wall in order to recharge the battery. The objective of this paper is to determine if it is possible to capture sufficient power in a cellular phone in order to charge the battery. It was being bombarded with energy waves every second of the day. Radio and television towers, satellites orbiting earth, and even the cellular phone antennas are constantly transmitting energy. If there was a way it could harvest the energy that is being transmitted and use it as a source of power. If it could be possible to gather the energy and store it could possibly use it to power other circuits. In the case of the mobile phone, this power could be used to recharge a battery that is frequently being depleted. The potential exists for mobile phones, and even more complicated devices pocket organizers, person digital assistants (PDAs), and even notebook computers to become completely wireless [2].

## 2. EMPLOYMENT OF SMART RFID

In this paper which is based on a very easiest concept, capture RF energy using an antenna, input it into a charge-pump and use this energy to power some other circuit [7], [8]. RF energy is transmitted to the circuit and the charge pump stores the energy in a large capacitor [1]. When

the amount of charge is large sufficient, the LED uses the stored energy to light for a moment. This is referred as charge-and-fire system. This kind of technology is very useful in Radio Frequency Identification applications. The method systems work is that when a chip passes through a scanner device, power is sent to the chip from the scanner. In previous systems, the frequency or amplitude of this signal was modulated by the chip and sent back. This method is named backscatter. The RFID system is suitable for batteries because they are small. Hence this method can be used for this system along with a good antenna and a charge pump. A charge pump should be able to handle the powering of the circuits and never will need to be serviced. Because the circuits are small, the requirement of power is very minimum.

### 2.1 Transmitter Section

The most basic transmitter setup consists of a piece of equipment that generates a signal whose output signal is then fed into an amplifier that is finally output through a radiating antenna the air interface. The RF source is a circuit that output a signal at a user-specified frequency and voltage. The choice of frequencies of the signal generator resides in the radio frequency band, 3 mega-hertz (MHz) to 3 giga-hertz (GHz). The frequency of 915MHz can be selected for this paper as it falls in one of the Industrial-Scientific-Medical (ISM) RF bands made available by the Federal Communications Commission for low power system, short distance experimentation. This frequency is chosen frequently for simplicity in using the available equipment [3]. It is not used for mass communication or anything else on a main scale, and therefore is not going to be interfered with, or interfere with other devices at low power system levels.

### 2.2. The Charge Pump

At this point, it is essential to describe what exactly a charge pump is, and how it works. A charge pump is a circuit when given an input in AC is able to output a DC voltage typically larger than a simple rectifier would generate. It can be thought of as a AC to DC converter that both rectifies the AC signal and increases the DC level. It is the foundation of power converters such as the ones that are used for many electronic devices today. The easiest design that can be

used is a peak detector or half wave peak rectifier. This circuit requires only a capacitor and a diode to function. The peak detector circuit diagram is shown in Figure 1. The description of how this circuit works is quite easy. The AC wave has two halves, one positive and one negative cycle. On the positive half cycle, the diode turns on and current flows, charging the capacitor. On the negative half of the wave, the diode is off such that no current is flowing in either direction. Now, the capacitor has voltage built up which is equal to the peak of the AC signal, hence the name peak detector [4]. Without the load on the circuit, the voltage would hold indefinitely on the capacitor and look like a DC signal, assuming ideal components. With the load, however, the output voltage decreases during the negative cycle of the AC input, shown in Figure 2.

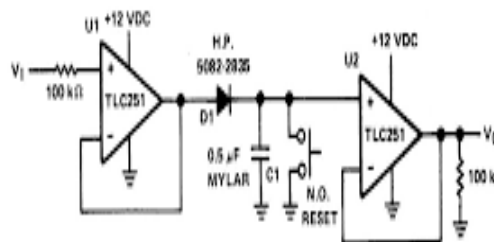

Figure 1: Peak Detector Circuit

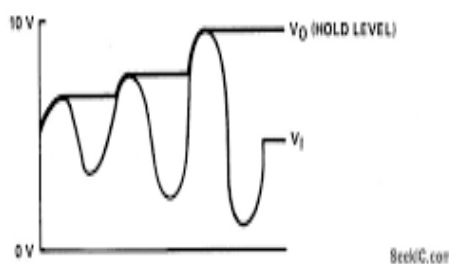

Figure 2: Output Waveform

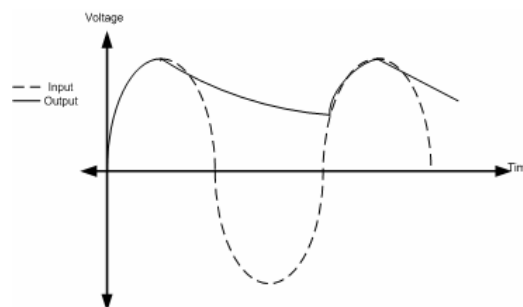

Figure: 3 Half-wave Peak Rectifier Output Waveform

The figure 3 shows that if the voltage decreases exponentially. This is due to the RC time constant. The voltage decreases in relation to the inverse of the resistance of the load,  $R$ , multiplied by the capacitance  $C$ . This type of circuit generates a lot of ripple, or noise, on the output DC of the signal. With more circuitry, that ripple can be reduced.

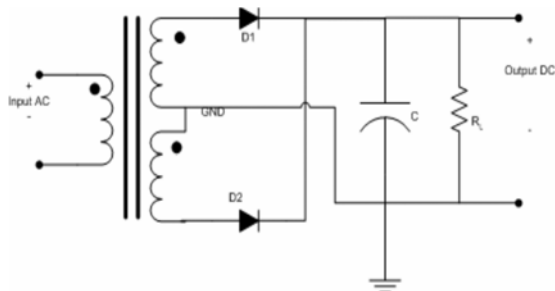

Figure: 4 Full-wave Rectifier Circuit

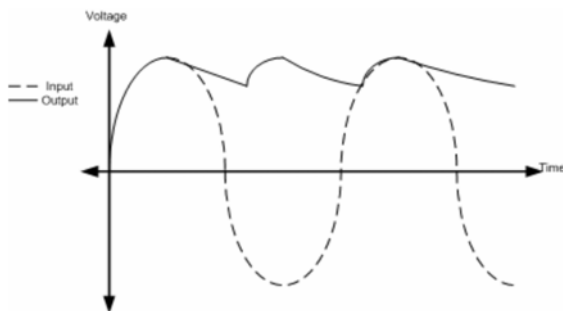

Figure: 5 Full-wave Rectifier Output Waveform

The next methodology illustrated in Figure 4 is a full-wave rectifier. Whereas the earlier circuit only arrests the positive cycle of the signal, here both halves of the input are captured in the capacitor. From this figure 5, it can be seen that in the positive half of the cycle, diode  $D1$  is on, diode  $D2$  is off and charge is stored on the capacitor. But, during the negative half, the diodes are reversed,  $D2$  is on and  $D1$  is off. The capacitor doesn't discharge nearly as much as in the earlier circuit, so the output has much less noise, as shown in Figure 5. It generates a cleaner DC signal than the half-wave rectifier, but the circuit itself is much more complicated with the outline of a transformer. This basically rules this methodology out for this paper because of the space needed to implement it.

The other methodologies for charge pumps are more difficult and all include transformers, like the full-wave rectifier etc. The

charge pump circuit is made of stages of voltage doublers. This type of circuit is referred as voltage doubler because in theory, the voltage that is received on the output is twice that at the input. The schematic in Figure 5 implicit one stage of the circuit.

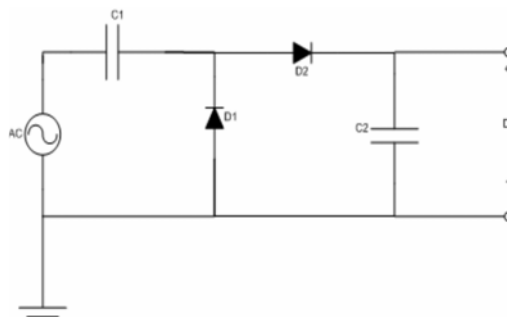

Figure: 6 Voltage Double Circuit

The RF wave is rectified by diode  $D2$  and capacitor  $C2$  in the positive half of the cycle, and then by diode  $D1$  and capacitor  $C1$  in the negative cycle. But, during the positive half-cycle, the voltage stored on  $C1$  from the negative half-cycle is transferred to  $C2$ . Thus, the voltage on  $C2$  is roughly two times the peak voltage of the RF source minus the turn-on voltage of the diode, hence the name voltage doublers [5], [6]. The most motivating feature of this circuit is that by connecting these stages in series, it can essentially stack them, like stacking batteries to get more voltage at the output. The response can be seen in Figure 6. This is where the other stages come in. If a second stage is added on top of the first, the only wave that the second stage seen is the noise of the first stage. This noise is then doubled and added to the DC of the first stage. Therefore, the more stages that are added, theoretically, more voltage will come from the system regardless of the input. Each independent stages, with its dedicated voltage doubler circuit, can be seen as a battery with open circuit output voltage  $V_o$  and internal resistance  $R_o$ .

### 2.3. Experimental Test Setup

The testing setup for this project is shown in Figure 7. As it can see that, the output of the charge pump circuit is input directly into the battery. This is one of the two ways to charge the battery. This is to power the phone through its DC input circuitry, and let it charge the battery. It was noted that by the implementation of this

system the battery can be charged at a rate of 2mV per second. This is an average result, obtained by comparing with conventional type chargers.

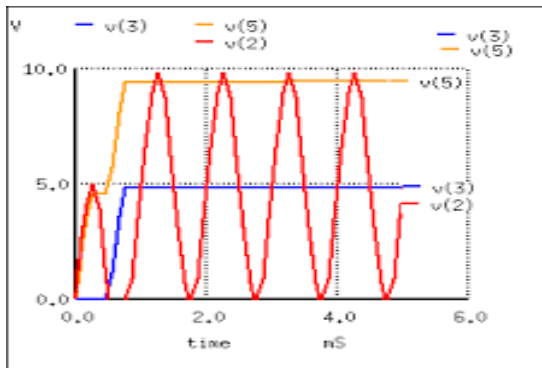

**Figure: 7 Voltage Doubler Waveform**

#### 2.4. The Antenna Section

The most straightforward option for the receiving antenna is to use an existing antenna that can be attained commercially. It was found that a quarter-wave whip antenna can be used for the testing purposes. This antenna is analogous to that used on car radios. It is named as quarter-wave antenna because it is designed so that its length is approximately one quarter of the wavelength of the signal. This means that for a 915MHz signal, with a wavelength equal 32cm, a quarter-wave antenna would have an 8cm length. A picture of the quarter-wave whip antenna is shown in Figure 8.

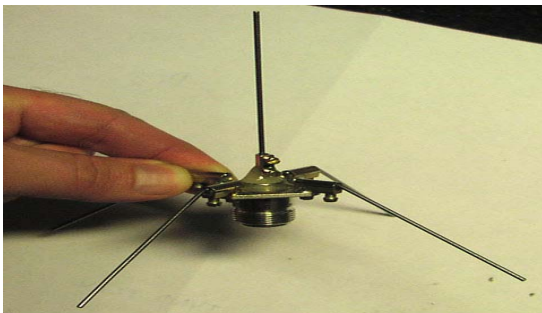

**Figure: 8 Quarter-wave Whip Antenna**

The large copper plate is the ground plane. The antenna is attached to the copper, with an SMA connector on the underside of the ground plane. This type of connector uses a simple screw mechanism allowing for easy connectivity with other circuits and test equipment. The cord is connected on the other side to the BNC connector of the board. As it can

see, this ground plane is rather large, too large to be used inside the stand for a mobile phone. It covers almost 50% more area than the stands that were selected for this purpose. Other types of antennas to consider are patches, micro strips, dipoles, and monopoles.

The patch antenna has two major problems

- 1) The first is that it also wants to be relatively large, on the order of the ground plane for the quarter-wave whip antenna.
- 2) The second reason is that it is highly directional, meaning that it only radiates, and accepts radiation, in one direction.

#### 2.5. Mobile Phone Testing

Since the objective of this paper is to charge the battery within the phone, the next step is testing and to try to charge the phone batteries through the phones with this setup. The power in a system is equal to the current in the system multiplied by the voltage in the system.



**Figure: 9 Mobile Phone Test Setup**

For the Nokia phone, the voltage and current ratings are 3.6 Volts and 0.35 Amps respectively or 1.26 Watts of power in the system in order to charge the nokia battery. However, the Motorola phone needs 5.9 Volts x 0.4 Amps, or 2.36 Watts, of power. These ratings were taken from the chargers that were supplied with each mobile phone. Figure 8 shows the setup used for the tests. The antenna is connected to the board through an SMA connector. The output of the circuit is sent straight to the phone through the plug that is used for charging the battery. The jack plugged into the phone was the phone connector end cut from the travel charger and connected to the board.

### 3. CONCLUSION

For business purposes or personal use, there becomes a need for an effectual way of charging the battery of the phone. Nevertheless, like most people, probably it does not seem good in being tethered to the wall. Envision a system where the cellular phone battery is continuously charged. No more perturbing about forgetting to charge the battery. It is the focus of this paper to deliberate the first step towards realizing this objective. Here, a first step towards an objective that would have thoughtful ramifications on the cellular phone industry and the portable electronic device industry as a whole has been envisaged. If this goal is realized it would be sure that wireless battery charging system will be a milestone in the account of wireless technology.

### REFERENCES

- [1] Nikola Tesla, "The Transmission of Electrical Energy Without Wires as a Means for Furthering Peace," *Electrical World and Engineer*. Jan. 7, p. 21, 1905.
- [2] Balakumar N. and Boselin Prabhu S.R., "Literature and Comparative Survey of Future Wireless Communication", *Galaxy: International Multidisciplinary Research Journal*, 4(1), 2016.
- [3] Elavarasan S. and Balakumar N., "A Research on Wireless Power Transmission using Distinguished Methodologies", *International Journal of Research and Engineering*, Volume 3, Number 7, 2016.
- [4] Balakumar N. and Boselin Prabhu S. R., "Real-World Wireless Power Transmission under Various Scenarios and Considerations", *International Journal of Innovative and Applied Research*, Volume 4, Issue 7, pp. 24-29. 2016.
- [5] Balakumar N. and Boselin Prabhu S.R., "Evaluation of Quality in Network and Interoperable Connectivity between IP Networks", *International Journal of Current Engineering and Scientific Research (IJCESR)*, Volume 3, Issue 9, pp. 81-85, 2016.
- [6] Boselin Prabhu S.R., Balakumar N., Rajeswari P. and Dinesh Kumar A., "Wireless Electricity Transfer Methodologies Using Embedded System Technology", *Journal of Engineering, Scientific Research and Applications*, Volume 2, Issue 1, 2016, pp. 81-89.
- [7] T. Paing, J. Shin, R. Zane, and Z Popovic, "Resistor emulation approach to low-power RF energy harvesting," *Power Electronics, IEEE Transactions on*, vol. 23, no. 3, pp. 1494--1501, May 2008.
- [8] J. Zbitou, M. Latrach, and S. Toutain, "Hybrid rectenna and monolithic integrated zero-bias microwave rectifier," *Microwave Theory and Techniques, IEEE Transactions on*, vol. 54, no. 1, pp. 147-152, Jan. 2006