



## A REVIEW ON MASSIVE MIMO FOR NEXT GENERATION WIRELESS COMMUNICATION SYSTEMS

Pratik A. Somaiya<sup>1</sup>, Jyoti R. Gangane<sup>2</sup>

<sup>1,2</sup>Savitribai Phule Pune University

Email:Pratiksomaiya1008@gmail.com<sup>1</sup>, jgangane.sit@sinhgad.edu<sup>2</sup>

### Abstract

**MIMO technology is being developed rapidly in the area of wireless communication. Massive MIMO refers to setting up a number of base stations with large number of antennas. It has shown improvements in energy and spectral efficiency using simple processing. The use of moderately large antenna arrays can improve the spectral and energy efficiency compared to single antenna system. Additional benefit of massive MIMO is that the cost requirement of components is less as low power components are used. In this paper, the benefit and challenges in massive MIMO systems are discussed. The energy efficiency achieved by massive MIMO systems are also discussed. This technology renders different problems but it also solves many problems that are the need of time. This paper reviews about massive MIMO concept and its benefits to wireless communication systems.**

**Index Terms: BS- Base Station, EE- Energy Efficiency, MIMO- Multiple-Input Multiple-Output, OFDM- Orthogonal Frequency Division Multiplexing, SM- Spatial Modulation, , TDM- Time Division Multiplexing.**

### I. INTRODUCTION

Multiple-input multiple-output (MIMO) technology is a topic of concern from the past two decades because it is proved to be efficient in terms of reliability and capacity of the wireless systems. In massive MIMO, large numbers of antennas are used, that means array of antennas are used with many antennas parallel

serves the devices [1]. In this all the benefits of the conventional MIMO systems are retained along with added features. These systems are focused on the parameters which are energy efficient, secure, robust and optimum use of spectrum [1]. If the number of antennas is more, then the degree of freedom of channel will increase thereby improving the performance [2]. MIMO technology is considered as a potential technology for future fifth generation (5G) wireless systems [13]. Spatial Modulation (SM) is attractive for multi-antenna wireless communications [3]. SM-MIMO is different from conventional systems because in SM-MIMO based systems there will be multi transmit antennas but only one transmit RF chain. Due to which the size, complexity and cost also gets reduced. If the Energy Efficiency (EE) is seen, if the power consumption is in a certain threshold then the EE will improve, because this parameter is needed to be reviewed as in MIMO systems, the density of the Base

Stations (BS) are increased [4]. Large number of terminals can always be accommodated by combining very large MIMO technology with conventional time (TDM) and frequency division multiplexing (OFDM) [2]. The designs can be made robust so that the failure of one or few antenna units will not affect the functioning of the system. Good channel knowledge is essential, on both uplink and downlink. In uplink, it is easy to accomplish by having the terminals, based on which the base station estimates the channel responses of each of the terminals. The downlink is tedious. In

conventional MIMO systems such as Long Term Evolution (LTE) standard, it is easy to estimate. But this is not the case with massive MIMO systems [1].

The Massive MIMO and SM-MIMO are shown in the Figure 1 and Figure 2 respectively.

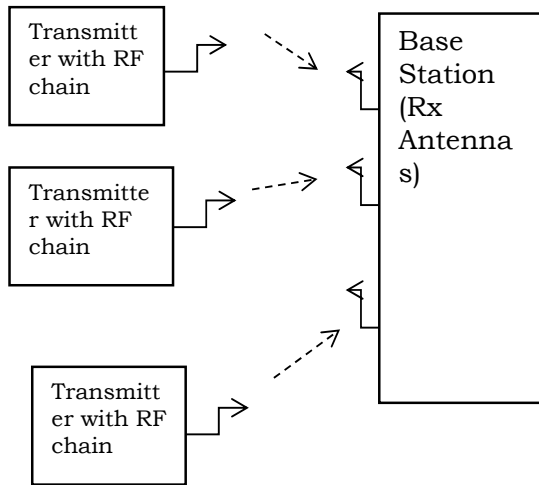

Fig. 1 Massive MIMO System

As shown in the above figure the conventional MIMO system in Fig. 1 has a single transmit antenna with a single transmit RF chain. The disadvantage of such system is that it cannot be used in areas where multiple antennas are present. To overcome this problem, SM-MIMO System is designed which consists of multi transmit antennas with single transmit RF chain as shown in Fig. 2. As there are many regions where antennas of different types are used for wireless communication, this proves to be useful.

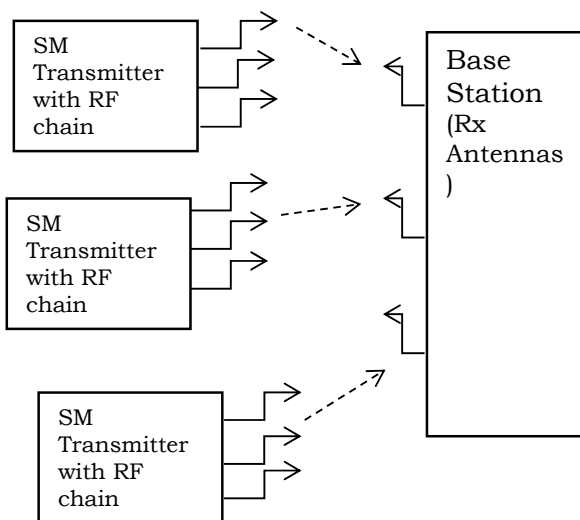

Fig. 2 SM-MIMO System

## II. POTENTIAL OPPORTUNITIES OF MIMO

In this section, the advantages that the massive MIMO system renders are reviewed. The opportunities available by using the antenna arrays followed by the performance characteristics of the system are discussed. The results obtained are based on [5].

### A. Point-to-Point MIMO

The main focus is to overcome the limitations of systems where the antennas are arranged in a compact, clustered fashion, both at the transmitter and the receiver. To overcome this problem, multiuser MIMO systems are being developed. Basically the point-to-point type of MIMO system will have a “p” number of antennas at the transmitter end and “q” number of antennas at the receiver end. The channel will decide the output. Each receiver antenna is subjected to the combination of all transmitter antennas [2].

The requirement is of narrow-band time invariant channel with a deterministic and constant channel matrix  $H \in \mathbb{C}^{p \times q}$ . The received signal vector ‘y’ can be expressed as

$$y = \sqrt{\rho}Hx + n \quad (1)$$

Where  $x \in \mathbb{C}^{p \times 1}$  is the transmit vector and  $n \in \mathbb{C}^{q \times 1}$  represents disturbance and noise,  $\rho = \text{scalar}$  (transmit power) [5].

### B. Multi-User MIMO

Multi User-MIMO systems are used to achieve good multiplexing gain of massive point-to-point MIMO systems by eliminating the problems due to unfavourable propagation environment [5]. These systems can simultaneously transmit to several users and flexibility to schedule the users is also provided. Advanced coding techniques are needed to be employed for such systems as simultaneous transmission is considered here. The user interference has to be minimum in MU-MIMO systems.

## III. TRANSMIT PROCESSING

The base of the information theory is needed to find out optimum transmission process. In this section several aspects of transmit time

processing of multiuser MIMO systems are discussed. Dirty Paper Coding technique is used. But it increases the cost and its practical implementation is rarely used. There are several aspects of transmit processing which are needed to be considered. They are TDD operation, pilot contamination, resource allocation and precoding and related tasks. Each of the above aspects is discussed below [6]:-

#### A. TDD Operation

In general, in Time Division Duplexing (TDD) systems uplink channel is used as an estimate of downlink channel. This is known as reciprocity. TDD is an alternative to CSI in time-varying channels [14]. The difference is in the transfer characteristics of the amplifiers and filters [6].

#### B. Pilot Contamination

When the TDD mode is employed then the resulting phenomenon is known as Pilot Contamination. As the channel coherence time is limited the pilot sequences are difficult to employ. To reduce it, non-orthogonal pilot sequences are employed which will affect the SI at the transmitter. To reduce the effects of pilot contamination channel estimation theory, precoding etc. are used.

#### C. Resource Allocation

The resources (antennas, users and power) that should be allocated to each user depend on the instantaneous CSI which may vary amongst users [6]. Generally, the total number of users are much higher than the number of transmit antennas; the system needs a resource allocation algorithm to select the set of users which best fits into the criterion. The resource allocation task is then to choose a set of users such as to satisfy the performance need.

#### D. Precoding and Related Techniques

Precoding technique is used for mitigating multiuser interference at the transmit side. Linear precoding techniques such as zero-forcing (ZF), minimum mean square error (MMSE) precoding are based on channel inversion operations and are attractive for their relative simplicity for MIMO systems with a small to moderate number of antennas [6].

## IV. RECEIVE PROCESSING

At receiver side, proper estimation and decoding is needed. In this section the receiver side processing in multiuser MIMO systems is discussed. Different algorithms are employed for the reception part.

#### A. Estimation and Detection

Estimation of parameters is essential task. The parameters such as gain, filter coefficients (receiver) and detection of transmitted symbol are needed to be determined. In standard MIMO systems algorithms such as linear MMSE and least-squares (LS) channel estimation are employed. These algorithms are cost ineffective. With the channel variations the output will also change, these are the drawbacks. The development of algorithms that overcome the above problems is need of future [6].

#### B. Iterative Detection and Decoding techniques

The Turbo principle of mitigation for several sources of disturbance is booming since last few years. With this, the iterative detection and decoding techniques are developed. Delays may get introduced and in future scope these delays may be eliminated.

## V. LIMITATIONS OF MASSIVE MIMO

#### A. Channel Reciprocity

If the propagation channel is affected by different materials with different magnetic properties then reciprocity is affected. The time-division duplexing operation relies on the propagation channel reciprocity. The hardware chains in the base station are not or may not be reciprocal between the uplink and downlink [1]. If the maximum phase difference between the hardware chains in case of uplink and downlink is less than  $60^\circ$ , then significant reduction in the gain can be observed. If the base station is properly calibrated then it is not necessary to calibrate the uplink and downlink chains, proper gain can be obtained. If the base station is not properly calibrated then effective techniques are needed to be used.

#### B. Pilot Contamination

As mentioned earlier, pilot contamination is an issue at transmit side processing. In every MIMO system a terminal is assigned with limited amount of orthogonal pilot sequence. The limit depends on the duration of the coherence interval divided by the channel delay spread [1]. In [1] the number of orthogonal pilot

sequence is limited to about 200 with coherence interval of 1 msec. If the pilots are reused from one cell to other then its effect can be seen as *Pilot Contamination*. The effect of pilot contamination is of less importance to classical MIMO but it is more for Massive MIMO. To deal with the pilot contamination, the following techniques can be employed: -

- Allocation of pilot waveforms can be optimized. The techniques needed for proper optimization is an ongoing research.
- Channel estimation algorithms or blind techniques may eliminate the negative impact of pilot contamination.

The precoding techniques at the transmit section can be used. Proper techniques are yet to be developed.

#### C. Effects due to channel

Massive MIMO systems are dependent on radio propagation environment. The channel conditions affect the throughput of Massive MIMO systems. To eliminate this problem, the channel behaviour is needed to be studied. Fading can also affect the output.

### VI. OPPORTUNITIES FOR RESEARCH

In this section the opportunities for the research in massive MIMO systems are discussed. The radical changes can be brought into the wave theory and propagation field through massive MIMO systems. It will introduce many problems which need research. The following areas are available: -

- Channel Properties: -  
When dealing with massive MIMO systems the properties related to the channel are needed to be considered. The analytical models can be designed to study about channel characteristics.
- Low cost hardware: -  
As in the massive MIMO systems a large number of RF chains, Analog-to-Digital (A/D) converters, Digital-to-Analog (D/A) converters etc. are needed, the economy study of the manufacturing unit should be done.
- Power consumption: -  
The power radiated should be controlled so that the efficiency of the system will

improve. The research can be done on techniques which can limit the power consumption.

- Deployment of new applications: -  
This includes the dedicated operation of an application. Dedicated applications can be designed which are specific to massive MIMO.
- Reduction in hardware imperfections: -  
The proposed MIMO system should be built with low cost components. The interference and accuracy can be controlled by controlling hardware factors. Smart systems can be developed which have the potential to overcome the problems.

Other opportunities are also available in which research can be done to improve the traditional MIMO systems.

### VII. CONCLUSIONS

In this paper, the massive MIMO systems are comprehensively described. The limitations and applications are also discussed. Different types of processing which is needed are also included. Energy and spectral efficiency play a very important role in these systems. Different algorithms which can improve the efficiency of such systems are the need of future. This technology has proven to be a goldmine for researchers. However to get benefited from the opportunities of MIMO, significant research is needed in hardware design, interference management and channel correlation. It will open many opportunities in the field of wireless communication and wave propagation.

### REFERENCES

- [1] E. G. Larsson, "Massive MIMO for Next Generation Wireless Systems," in *IEEE Communications Magazine*, 2014.
- [2] F. Rusek, "Opportunities and challenges with very large arrays," in *IEEE Signal Processing Magazine*, January 2013.
- [3] T. L. Narasimhan, "Large-Scale Multiuser SM-MIMO Versus Massive MIMO," Indian Institute of Science Bangalore, India.

- [4] H. Q. Ngo, "Energy and Spectral Efficiency of Very Large Multiuser MIMO Systems," in *IEEE Transactions On Communications*, VOL. 61, NO. 4, April 2013.
- [5] A. Ashikhmin, "An Overview of Massive MIMO: Benefits and Challenges," in *IEEE Journal Of Selected Topics In Signal Processing*, VOL. 8, NO. 5, October 2014.
- [6] R. C. d. Lamare, "Massive MIMO Systems: Signal Processing Challenges and Research Trends," in *arXiv:1310.7282 [cs.IT]*, October 2013.
- [7] T. L. Marzetta, "Special Issue on Massive MIMO," in *Journal of Communications and Networks, IEEE & Korea Information and Communications Society*, January 2014.
- [8] A. Farhang, "Massive MIMO and Waveform Design for 5th Generation Wireless Communication Systems," November 2014.
- [9] M. Wenk, "K-Best MIMO Detection VLSI Architectures Achieving up to 424 Mbps," Zurich, Switzerland.
- [10] F. Boccardi, "Five Disruptive Technology Directions for 5G," in *IEEE Communications Magazine*.
- [11] W. Liu, "Energy Efficiency Comparison of Massive MIMO and Small Cell Network," in *GlobalSIP 2014: Massive MIMO Communications*, 2014.
- [12] H. Wang, "Multimedia over Massive MIMO Wireless Systems," 2015.
- [13] Z. GAO, "MMWAVE Massive-MIMO-based Wireless Backhaul for the 5G Ultra-Dense Network," in *IEEE Wireless Communications*, October 2015.
- [14] A. A. T. L. M. S. V. J. Jose, "Pilot Contamination and Precoding in Multi-Cell TDD Systems," in *IEEE Transactions on Wireless Communications*, August 2011.