



EXPERIMENTAL INVESTIGATIONS ON THERMAL DIFFUSIVITY OF CO₂ SILICATE MOULDS

Dr.R. Venkat Reddy

Dept.of Mech.Engg., Anurag Group of Institutions, Hyderabad

ABSTRACT

The present study was carried out to determine the engineering properties of foundry sand to demonstrate the process parameters of CO₂-silicate moulds by using “Design of Experiments” in which all the variables will vary simultaneously. A temporary mould is prepared with the mixtures of sand, Sodium silicate to bind sand grains and some additives like bentonite and CO₂ gas were used to hydrolyze the mass of silicate sand. The process parameters considered are CO₂ gassing time, sand particle size, percentage of Sodium Silicate and time taken for heating process. The experimental investigations of thermal properties namely thermal diffusivity is studied to determine the effect of Sodium silicate, CO₂ gassing time. The adequacy of models is tested by the Analyses of Variance ANOVA which uses a computer program and accuracy by experimental data. Thus, the findings of this research suggest that the determination of individual, interactive and higher order effects of process parameters on the thermal properties of foundry sand are identified to a greater extent the rate of heat extraction from castings and also influences their quality of castings.

Key words: Moulds, Foundry sand, Sodium Silicate, CO₂ gas, Thermal Properties.

1.1 INTRODUCTION

In this process uses sand which has been mixed with Sodium silicate. CO₂ gas forms a weak acid to hydrolyze the Sodium Silicate and forms amorphous Silica to become a bond. This bonding action is from the Sodium Silicate itself. The use of CO₂ gives an almost instantaneous set. The mould is fully hardened before the

pattern is drawn from the mould sections. Sodium Silicate is a versatile and widely employed solution. Sodium Silicate is likewise a liquid glass for good reason. When the water is dissolved it evaporates away for developing Sodium Silicate moulds by using CO₂ at optimum gassing time [1]. The parameters are Sand particle size (number), Percentage of Sodium Silicate (%), CO₂ gassing time (seconds) and Time Taken for heating (minutes). The range of Sand particle size number was selected (1.18, 2, 2.36), Percentage of Sodium Silicate (2%, 4%, 6%), CO₂ Gassing time (20 – 60 seconds) and Time Taken for heating (10-60 minutes) was selected. Moulding materials are fire resistant granular materials with several types of organic binders and additives in a controlled ratio [2].

1.2 EXPERIMENTAL INVESTIGATIONS

Thermal properties determine to a large extent the rate of heat extraction, nucleation and growth within castings. Knowing thermal properties of the sand the desired directional solidification at different sections of the casting were created to improve its quality. Therefore, the following thermal properties of foundry sand will be studied. Thermal Diffusivity experiments were carried out at laboratory scale level to determine the basic mechanical properties of foundry sand. Sodium Silicate as a binder was used to prepare the moulds [3]. The Chemical reaction of Sodium Silicate with base sand is as follows [3],

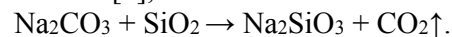

Thermal properties were determined by heating the moulds by electrical instrumentation. The transfer of heat through the mould was noticed by Thermocouples. The aforementioned thermal properties were calculated using

empirical formulas. The effect of Sodium Silicate, Grain size distribution, Number of ramming strokes and CO₂ gas passing time on heat transfer of the moulds was found. Materials and Testing of Moulding Sands that were used in this research are Foundry Sand, bentonite, Sodium Silicate gel and water obtained from the foundry laboratory. The equipment that was used in this research for finding mechanical properties is Universal Sand Strength Testing Machine and for finding thermal properties is Heating Testing Equipment.

Heating Coils is a special heating device that is shaped in a spiral design. The coil is typically made from a copper and heated through electrical current. When the coil is charged with electric power, it becomes red hot. This coil produces heat that is transferred into the surrounding area with a fan. A heating coil is also known as protectors.

A thermometer has two important elements, temperature sensors in which some physical change occurs with temperature and some means of converting this physical change into a numerical value. When the metal tip of the thermometer comes into contact with the material it is testing, it conducts heat energy to the mercury. The mercury turns into liquid and so it expands. It begins to rise up the tube where it stops is where we can take the temperature reading on the scale. Therefore, electrical instruments have a limited time response. Electrical Testing and Measurement devices can tell that a circuit or wire is energized as well as how much voltage or current an electrical circuit is carrying. By adjusting rheostat the voltage is set to be at 75V and current is set to be at 2A. Range of the instruments used: Rheostat (100W/5A), Voltmeter-75V/150V/230V (MI), Ammeter 5A/10A (MI).



Figure1 Electrical Measuring Instruments

In heat transfer analysis, thermal diffusivity is the thermal conductivity divided by density and specific heat capacity at constant pressure. It measures the ability of a material to conduct thermal energy relative to its ability to store thermal energy. It is usually denoted by α

$$\alpha = \frac{K}{\rho C_p} \text{ where}$$

K is thermal conductivity in W/mK

ρ is the density

C_p is the specific heat capacity in J/KgK

Thermal diffusivity is a material specific property for characterizing unsteady heat conduction. This value describes how quickly a material reacts to a change in temperature. Thermal diffusivity of a medium is the thermo physical property that determines the speed of heat propagation by conduction during changes of temperature with time. The higher the thermal

diffusivity, the faster the heat propagation. Thermal diffusivity is related to thermal conductivity, specific heat and density. According to the formulae, thermal diffusivity affects any conductive transient heat transfer process within the medium.

1.3 DESIGN FACTORIAL METHOD

Full factorial experiment is an experiment whose design consists of two or more factors, each with discrete possible values or “levels”, and whose experimental units take on all possible combinations of these levels across all such factors. A full factorial design may also be called a fully closed design. Such an experiment allows the investigator to study the effect of each factor on the response variable, as well as the effects of interactions between factors on the response variable. Further, a parameter need to be minimized with respect to a combination factors, whereas the one factor at a time procedure will not be considered. In this case 24

factorial design is used, four factors were studied designated A to D. The four factors selected were sand grain size, Sodium silicate percentage, Carbon dioxide gassing time and Time taken for heating process. Experimental work based on two levels and four factors has been carried out to establish the effect of factors considered on Sodium silicate moulds. ANOVA technique

determines the controlling factor which significantly affects the quality characteristics.

Factors: 4

Base Designs: 4, 6

Runs: 6

Replicates: 5

The corresponding Design Matrix Parameters are shown in the Table 1 as below.

Table 1: Design Matrix Parameters Considered In the Sand Systems

Run	Grain size (A)	Percentage of Sodium Silicate (B)	Carbon dioxide gassing time (C)	Time taken for heating (D)	Interactions					
					AB	AC	AD	BC	BD	CD
1	-1	-1	-1	-1	1	1	1	1	1	1
2	1	-1	-1	-1	-1	-1	-1	1	1	1
3	-1	1	-1	-1	-1	1	1	-1	-1	1
4	1	1	-1	-1	1	-1	-1	-1	-1	1
5	-1	-1	1	-1	1	-1	1	-1	1	-1
6	1	-1	1	-1	-1	1	-1	-1	1	-1

1.4 EXPERIMENTAL PROCEDURE FOR CO₂-SILICATE MOULDS

Selection of sand grain size by using Sieve Shaker, Firstly a certain amount of foundry sand (say 1000g) of unknown grain size is taken and the size of the sand particle is measured by using sieve shaker machine. Sieve shaker which consists of stack of sieves for the purpose of separating a soil or other granular material sample into its component particles by size [4]. The stack of sieves is composed of sieves of different sizes. The sample is placed into the top sieve of the stack, and as the sieve shaker agitates the sample, the individual components shift through each of the sieve in turn with each one retaining particles of a successively smaller size and finally grain size of particular sand is obtained by using following observations.

Sieving of sand is obtained grain size of particular sand of amount 30kg is sieved. Weighing of required amount of sands for preparing moulds, and of particular grain size is weighted of amount 1000 grams by using weigh

balance machine and 6% bentonite powder is mixed with this sand. Bentonite plays an important role in the preparation of moulds. Preparation of moulds by adding additives and binders, Take 1000g of sand, 6% of bentonite powder and mix it well in the container and pour 2% of Na₂ SiO₃ which appears as a Sodium gel plus 6% of water is added and stir it well until it becomes wet. Na₂ SiO₃ is used as a binder for preparing of moulds. The chemical reaction of Na₂ SiO₃ with base sand is as follows:

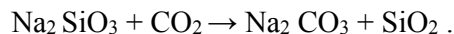

By using Silica gel the moulds becomes very hard. Certainly by varying Na₂ SiO₃ (8%) and mix it well with the sand mixture and the required process is taken place [5] is as shown in figure 2. Drying the moulds by passing CO₂ gas, after preparation of sand moulds CO₂ gas is allowed to pass through these moulds. By using the obtained 2% of Na₂ SiO₃ five sand moulds are prepared and CO₂ gas is allowed on every mould by varying CO₂ - gassing time (i.e 20, 30,40,50,60 sec). It is left over for 1 day so that

the sand moulds become very hard when compared previously is as shown in figure 3. Drilling Process is done after the moulds become hard; the centre of the mould is marked. Holes are drilled on two sides of the centre hole for the

purpose of placing thermometers. The procedure is to be done for 2% to 8% of Na_2SiO_3 by varying CO_2 gassing time (i.e. 20, 30, 40, 50, 60 sec) for every mould is as shown in figure 4.



Figure 2 Mould Cavity of Sheet Metal with CO_2 silicate moulds Figure 3 Passing of CO_2 gas Figure 4 CO_2 – Silicate Mould after drilling process.

Next process is heating the moulds which influence the properties of sand moulds. Heating of moulds will be taken place by using the Electrical Measuring Appliances such as Voltmeter, Ammeter, Rheostat, Heating Coils

and Thermometers. The heated moulds are heated and their temperatures are noted down which are used for calculation of Thermal Diffusivity. The experimental setup is shown below:

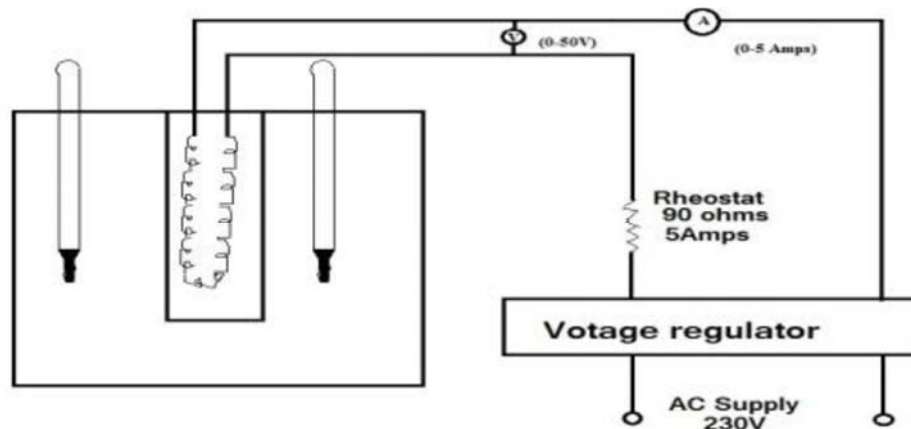

Figure 5 Schematic Diagrams for Experimental Measuring Instruments

Connections are to be made as per the circuit diagram. Heating coils is to be placed in middle of the hole which is on the mould and thermometers are to be placed on two sides of the holes. Initial readings of temperatures are noted. Then power is supplied and by varying Rheostat the Voltmeter is adjusted at 75V, ammeter is adjusted at 2A throughout the process. By this the moulds will be heated and for every ten

minutes the temperature readings is noted down. The process is taken place for 2% to 8% Na_2SiO_3 sand moulds and the required readings were noted. Then the thermal properties are calculated for every mould by using the formulae's.

1.5 RESULTS AND DISCUSSIONS

1.5.1 Effect on Thermal Properties of Varying Parameters

In the present work, an attempt has been made to study the effect of Sodium Silicate percentage, CO₂ gassing time, heating temperatures and Grain size of sand on the thermal properties. Experimental setup for CO₂ silicate moulding process is shown in figure 3.6. 1000g of sand was mixed with 6 weight percentage of bentonite and 4 weight percentage of tempering water added. Sodium silicate added at 2,4,6 weight percentages and the supply of CO₂ gassing times of 20 sec, 30 sec, 40 sec, 50 sec and 60 sec. The moulds are centrally drilled to accommodate the heating coil and two more blind holes are drilled to insert thermometers.

The setup is as shown in the figure 4 about 5mm thick layer of glass wool is surrounded to the specimen to minimize the heat loss. During experimentation, voltage and current are kept constant to supply same input for all specimens. The rising temperatures are measured at regular intervals of time. The results are tabulated as shown with table 2 to 3. Aforementioned thermal properties were calculated using empirical formulas by substituting their values. Results were ascertained and found thermal properties by means of graphical representation. The influence of variables considered in the work on the thermal properties will be critically discussed. Using ANOVA, the experimental values are checked for confirmation that is shown as below

TABLE 2 Design Parameters Obtained For Thermal Diffusivity

S.No	Grain Size A	% of Na ₂ SiO ₃ B	CO ₂ gassing time C	Time Taken D	Thermal Diffusivity α
1	1.18	2	20	10	277.533
2	2.36	2	20	10	116.180
3	1.18	6	20	10	178.139
4	2.36	6	20	10	185.887
5	1.18	2	60	10	163.201
6	2.36	2	60	10	104.073

TABLE 3 Estimated Effects and Coefficients

TERM CONSTANT	ESTIMATED EFFECT	CO-EFFICIENT	T- Value	P-Value
A	-80.29	-40.14	-11467.18	0.0
B	12.66	6.33	1807.46	0.0
C	20.45	10.22	2920.23	0.0
D	-94.22	-47.11	-13457.34	0.0
A×B	-0.64	-0.32	-91.29	0.0
A×C	-47.68	-23.84	-6809.20	0.0
A×D	11.01	5.51	1572.74	0.0
B×C	13.95	6.97	1991.74	0.0
B×D	4.00	2.00	571.05	0.0
C×D	60.17	30.08	8593.00	0.0
A×B×C	-47.63	-23.81	-6802.13	0.0
A×B×D	-19.58	-9.79	-2796.21	0.0
A×C×D	-33.18	-16.59	-4738.42	0.0
B×C×D	-9.55	-4.78	-1364.66	0.0

1.5.2 Main effect of thermal properties

A main effect situation is when there exists a consistent trend among the different values of a factor. A main effect is a plot of the means at each level of a factor. A main effect occurs when the mean response changes across the levels of a factor and also uses main effect plot to compare the relative strength of the effects across the factors. In this graph, when the line is horizontal (parallel to x-axis) then there is no main effect

and when the line is not horizontal then there is a main effect present.

In Main Effect Plot, Percentage of Sodium Silicate (B) and CO₂ gassing effect (C) have very small effect on Thermal Diffusivity. Other Parameters like Grain Size (A) and Time taken (D) for heating show a great influence on Thermal Diffusivity.

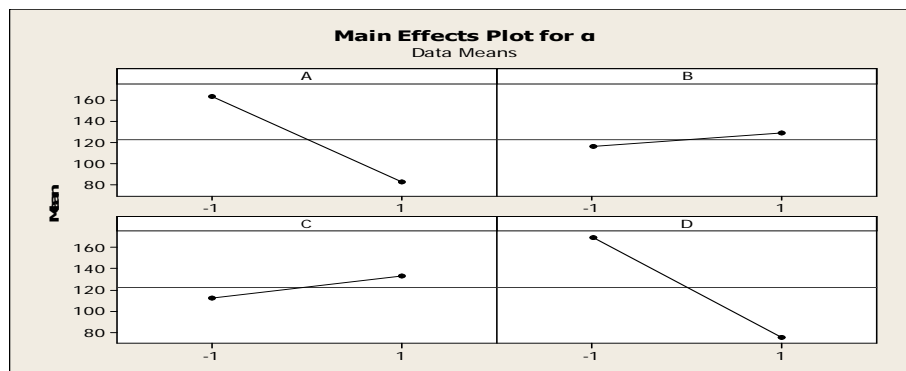

Figure 6 Main Effects for Thermal Diffusivity

CONCLUSIONS

Based on the Experimental study the following Conclusion is obtained.

1. Thermal diffusivity increases with increase in Sodium silicate percentage and decreases further increase in Sodium silicate.
2. Thermal diffusivity increase with increase in CO₂ gassing time and decreases further increase in CO₂ gassing time.

REFERENCES

- [1] Waisu Ajibola Ayoola, Samson Oluropo Adeosun, Olujide Samuel Sanni, Akinlabi oyetunji, "Effect of Casting mould on Mechanical properties of 6063 Aluminium Alloy", *Journal of Engineering Science and Technology*, 2012, Vol.7, No.1, 89-96.
- [2] Gaosheng Wei, Yusong Liu, Xiaoze Du, Xinxin Zhang, "Gaseous Conductivity Study on Silica Aerogel and its Composite Insulation Materials", *Journal of Heat Transfer*, 2012, Vol.134, pp.041301-5.
- [3] Wang Jina, Fan Zitian, Zan Xiaolei and Pan Di, "Properties of sodium Silicate bonded sand hardened by Microwave heating", *Research & Development*, 2009, Vol.6, No.3, pp.191-196.
- [4] Alain C.Pierre and Arnaud Rigacci, "SiO₂ Aerogels", *Advances in Sol-Gel Desired Materials and Technologies*, 2011, pp.21-45.
- [5] Wang Ji-na, Fan Zitian, Wang Hua-gang, Dong Xuan-pu, Huang Nai-yu, "An improved Sodium Silicate binder modified by ultra-fine powder materials", *Research & Development*, 2007, Vol.4, No.1, pp.26-30.