



FUZZY LOGIC BASED SENSORLESS STATOR FIELD ORIENTATION SPEED CONTROL OF SINGLE PHASE INDUCTION MOTOR

Sundaram A¹, Dr.G.P.Ramesh²

¹Research Scholar, Department of Electrical and Electronics Engineering,
St.Peter University.

²Department of Electronics and Communication Engineering,
St.Peter University,rameshgp@yahoo.com

Abstract

Single phase induction motors run at constant speed and hence finds its application not only in the industries but also in the traditional home appliances and low power rural equipments. The traditional method followed for speed measurement use sensors that are cost effective. A sensor less system is suggested where the speed is estimated instead of measured would considerably reduce the cost and complexity of the drive system. In the proposed system a sensor less indirect stator flux oriented control using fuzzy logic is implemented to control the single phase induction motor drive. Among various control methods the field oriented control (FOC) is widely used to obtain a high dynamic performance and provide a better solution to satisfy emerging industrial requirements. The main and auxiliary winding stator currents are measured and a reference q-axis current is generated through the control algorithm which is fed in the embedded system. The error of the measured q-axis current from its reference value feeds the integral controller. During recent years, many research laboratories have focused on variable-speed drives, especially for the SPIM, and major improvements have been achieved. The availability of low-cost static converters makes possible the economic use of energy and improvement of the quality of the electromagnetic torque in SPIM.

Keywords: Fuzzy logic, speed measurement, sensorless system, variable speed drives

1. INTRODUCTION

SPIMs operated from a fixed voltage source finds a limited application with sever constrains. In recent years the situation is changed where SPIMs are used under challenging environment, supplied by variable voltage and variable frequency inverters for the applications of variable speed air conditioners and refrigerators. The advantage of variable speed operations of SPIM finds a lot of opportunity to replace the three phase induction in various industrial applications at a low cost. In this paper the field orientation control of induction motor is employed to obtain high dynamic performance in the drive system. The main focus area is to improvement the motor control without a mechanical sensor. The single phase induction motor drive is controlled by indirect stator flux oriented control using fuzzy logic without sensors. The main and auxiliary winding stator currents are measured and that of a reference q-axis current is generated through the control algorithm which is fed in the embedded system. The system consists of following components single phase induction motor, Inverter unit and a microcontroller. Fig. 1 shows the block diagram of SPIM with controller unit.

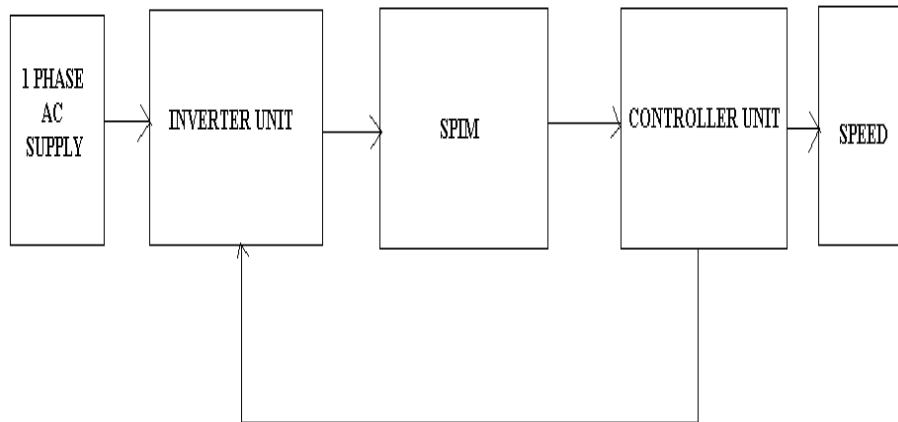

Fig.1 Block diagram of SPIM with controller unit

The rectifier is connected to a three phase supply and is connected with the DC link and inverter unit. The inverted current is given to the single phase induction motor then the current is sensed using a fuzzy controller. The feedback from the controller is given to the gating circuit of the inverter and the speed is sensed from the current

obtained. There are no sensors used so that the cost and complexity of the circuit is minimized.

2. SENSORLESS SPIM

Fig. 2 shows the block diagram of a sensor less SPIM. The rectifier converts the AC to DC. The DC link removes the ripples.

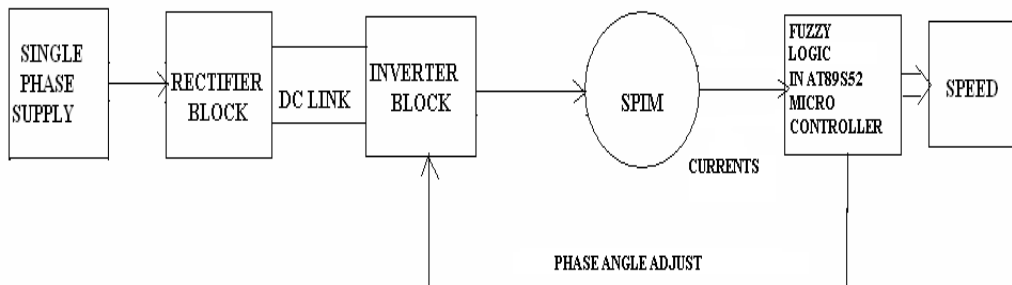

Fig. 2 Block diagram of sensor less SPIM

The inverter inverts the DC supply to AC and drives the single phase induction motor. The q axis and the d axis currents of the SPIM are obtained by the micro controller where the fuzzy logic is implemented. The fuzzy controller is used to calculate the speed by comparing the obtained current with the reference current. The SPIM model equations are more complex than that of the three-phase induction machines, because the main and auxiliary stator windings have different resistances and inductances. The use of field orientation control for an unbalanced single-phase machine requires special attention because the mathematical model for this type of machine is similar to that of an asymmetrical

two-phase machine. A particular converter topology and control are used to supply the SPIM based on three-leg to generate two-phase voltage source inverter in which sinusoidal pulse width modulation (PWM) is applied. The estimated speed is obtained only from the measurement of the main and auxiliary windings stator currents and that of a reference q-axis current are generated by the control algorithm. A speed estimation method is proposed to overcome the problems of system complexity and cost. Simulation and experimental results are presented to demonstrate the main characteristics of the proposed drive system.

The sensorless speed control algorithm is implemented at rated, low, and zero speed operation. The errors are calculated with the help of main winding current and auxiliary winding current which are taken as the q axis and d axis currents. The calculated error is processed and accordingly the phase angle of the inverter switch is adjusted. The evolution of the q-axis current error according to the slip angular frequency for a reference speed of 1500 r/min with nominal load torque is applied to the motor at steady state. It is observed that there is a linear relationship between q-axis current error and slip angular frequency for whole range of operation.

3. ANALYSIS OF SPIM

The single phase induction motor in stator frame is given by the following equations

$$V^{s_{sd}} = R_{sd} i^{s_{sd}} + d \phi^{s_{sd}} / dt \tag{1}$$

$$V^{s_{sq}} = R_{sq} i^{s_{sq}} + d \phi^{s_{sq}} / dt \tag{2}$$

$$0 = R_r i^{s_{rd}} + d \phi^{s_{rd}} / dt + \omega_r \phi^{s_{rq}} \tag{3}$$

$$0 = R_r i^{s_{rq}} + d \phi^{s_{rq}} / dt - \omega_r \phi^{s_{rd}} \tag{4}$$

$$\phi^{s_{sd}} = L_{sd} i^{s_{sd}} + M_{srd} i^{s_{rd}} \tag{5}$$

$$\phi^{s_{sq}} = L_{sq} i^{s_{sq}} + M_{srq} i^{s_{rq}} \tag{6}$$

$$\phi^{s_{rd}} = L_r i^{s_{rd}} + M_{srd} i^{s_{sd}} \tag{7}$$

$$\phi^{s_{rq}} = L_r i^{s_{rq}} + M_{srq} i^{s_{sq}} \tag{8}$$

$$T_e = n_p (M_{srq} i^{s_{sq}} i^{s_{rd}} - M_{srd} i^{s_{sd}} i^{s_{rq}}) \tag{9}$$

where $V^{s_{sd}}, V^{s_{sq}}, i^{s_{sd}}, i^{s_{sq}}, \phi^{s_{sd}}, \phi^{s_{sq}}, \phi^{s_{rd}}, \phi^{s_{rq}}$, are the main and auxiliary voltages, current and fluxes of stator and rotor in the stator reference frame: $L_{sd}, L_{sq}, L_r, M_{srq}, M_{srd}$ denote the stator and rotor self and mutual inductances. R_{sd}, R_{sq}, R_r denote stator and rotor resistance. ω_r, T_e, n_p are the rotor angular frequency, the electromagnetic torque and the pole pairs.

Equations (1) to (8) present the model of an asymmetrical two-phase machine. Due to the unequal resistances and inductances of the main and auxiliary windings, it causes an oscillating term in the electromagnetic torque.

4. ANALYSIS OF SPEED CONTROL ALGORITHM

The proposed method for speed estimation is based only on measurement of main and auxiliary winding stator currents generated by control algorithm. Keeping the main and auxiliary current as d axis and q axis current, the influence of slip angular frequency is studied over q axis current. We obtain the following reference current with stator flux reference and slip angular frequency as given below

$$s i^{sf_{sq1}} = - \frac{1}{\sigma_d \tau_r} i^{sf_{sq1}} + \frac{\phi_{s1} \omega_{sl}}{\sigma_d L_{sd}} - \omega_{sl} i^{sf_{sd1}} \tag{10}$$

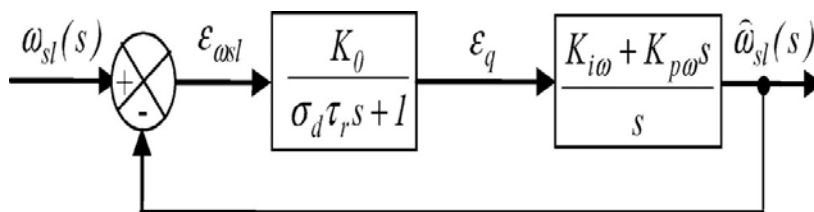

Fig. 3 Block diagram of slip angular frequency estimation

The slip angular frequency error is defined by

$$\xi_{\omega sl} = \omega_{sl} - \hat{\omega}_{sl} \tag{11}$$

where $\hat{\omega}_{sl}$ is the estimated slip angular frequency.

The error between measurement and reference q axis current is given by

$$\xi_q = i^{sf_{sq1}} - i^{sf_{sq1}} \tag{12}$$

Replacing these errors in the equation (10) we get

$$s \xi_q = - \frac{1}{\sigma_d \tau_r} \xi_q + \frac{\phi_{s1}}{\sigma_d L_{sd}} \xi_{\omega sl} - \xi_{\omega sl} i^{sf_{sd1}} \tag{13}$$

From the above equations the transfer function connecting the slip angular frequency error to the q axis current error is obtained.

$$\frac{\xi_q(s)}{\xi_{\omega sl}(s)} = \frac{K_0}{\sigma_d \tau_r s + 1} \tag{14}$$

where $K_0 = -\tau_r (\dot{\phi}_{s1} - \sigma_d L_{sd} i_{sd10})$
 with i_{sd10} is the steady state d axis current.

The closed loop transfer function can be represented by

$$\omega_{sl}(s) = \frac{\omega_0^2}{s^2 + 2s\zeta\omega_0 + \omega_0^2} k_{pw}/k_{iw} s+1 \quad (15)$$

In this paper, the parameters of PI controller are determined to obtain response without overshoot. The PI controller parameters are given by

$$k_{iw} = \frac{\sigma_d \tau_r (K_c / T_r)^2}{K_0} \quad (16)$$

$$k_{pw} = \frac{2\sigma_d \tau_r \zeta (K_c / T_r) - 1}{K_0} \quad (17)$$

where T_r is defined as the time required for the step response to rise from 5% of steady state value to 95% of steady state value. K_c is the constant obtained by $\omega_0 T_r = K_c$.

5. EXPERIMENTAL SETUP

To check the performance of the proposed method, a proto-type of the sensorless ISFOC of a SPIM drive is implemented. The experiment is

done using MATLAB-Simulink and micro controller board. The SPIM is fed by a three-leg voltage source inverter (VSI) using six MOSFETs. The other ends are tied together and connected to third half bridge. With this drive topology, control becomes more efficient but the control algorithm becomes more complex. The winding voltage is controlled to achieve the phase difference between effective voltages across the main and auxiliary winding in order to have a 90 degree phase shift to each other.

To reduce the ripple current of SPIM drive a suitable PWM for three leg two phase inverter is implemented. We propose sinusoidal PWM method instead of space vector pulse wide modulation. In three-leg inverter, two legs control the main and auxiliary winding of the SPIM voltages and the other leg controls the offset voltage. The PWM signals for three-leg two-phase inverter is realized in the following way.

- 1) PWM duty cycle is calculated according to v_{sdref} for leg 1.
- 2) PWM duty cycle is calculated according to v_{sqref} for leg 2.
- 3) Duty cycle is taken constant equal to 0.5 to provide a zero reference voltage for leg 3.

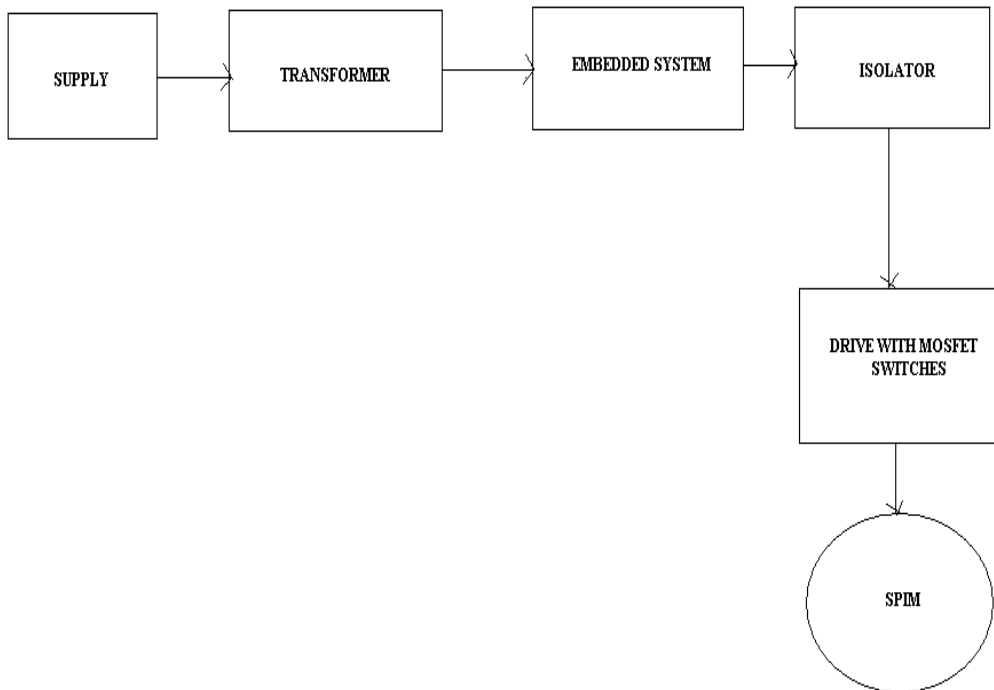

Fig. 4 Over view of experimental setup

Fig. 4 shows the over view of experimental setup. The supply is given to the transformer to transform the energy from the primary winding to the secondary winding through mutual induction. After transformation the energy is given to the embedded system where the current is controlled to the nearest value as possible to

the reference value. It is brought in to control by the fuzzy logic control algorithm. If the supply is above the reference value it will bring down the voltage to the nearest value of the reference voltage. If the supply is below the reference value it will bring up the voltage to the nearest value of the reference voltage.

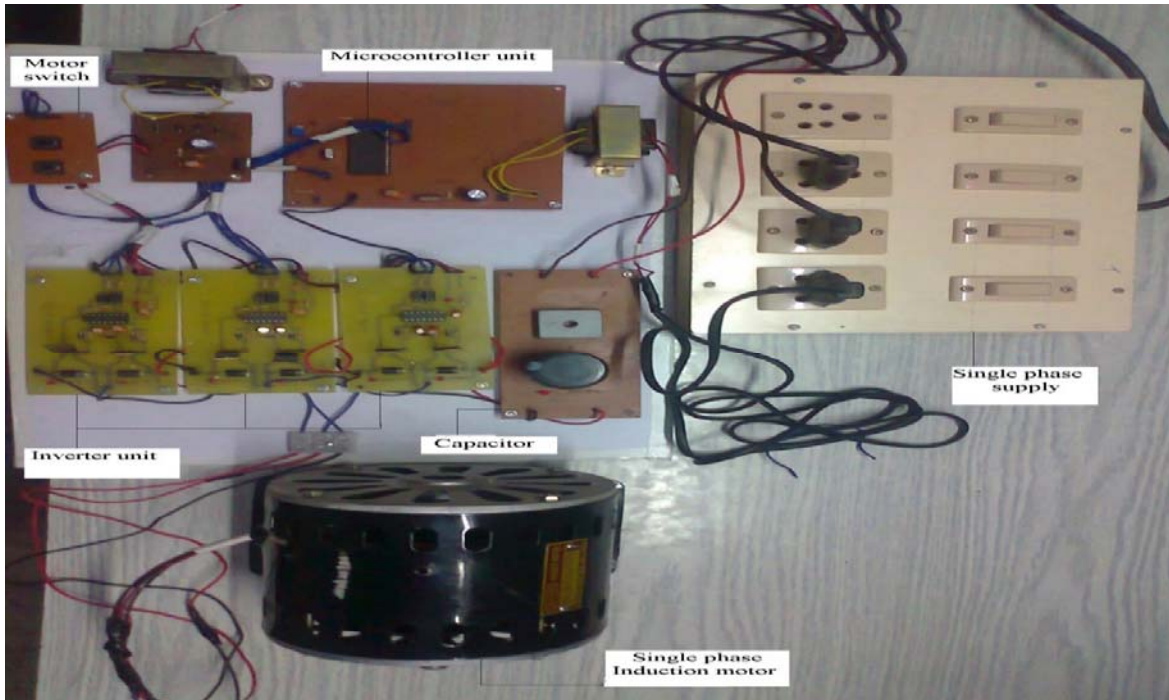

Fig. 5 Hardware overview

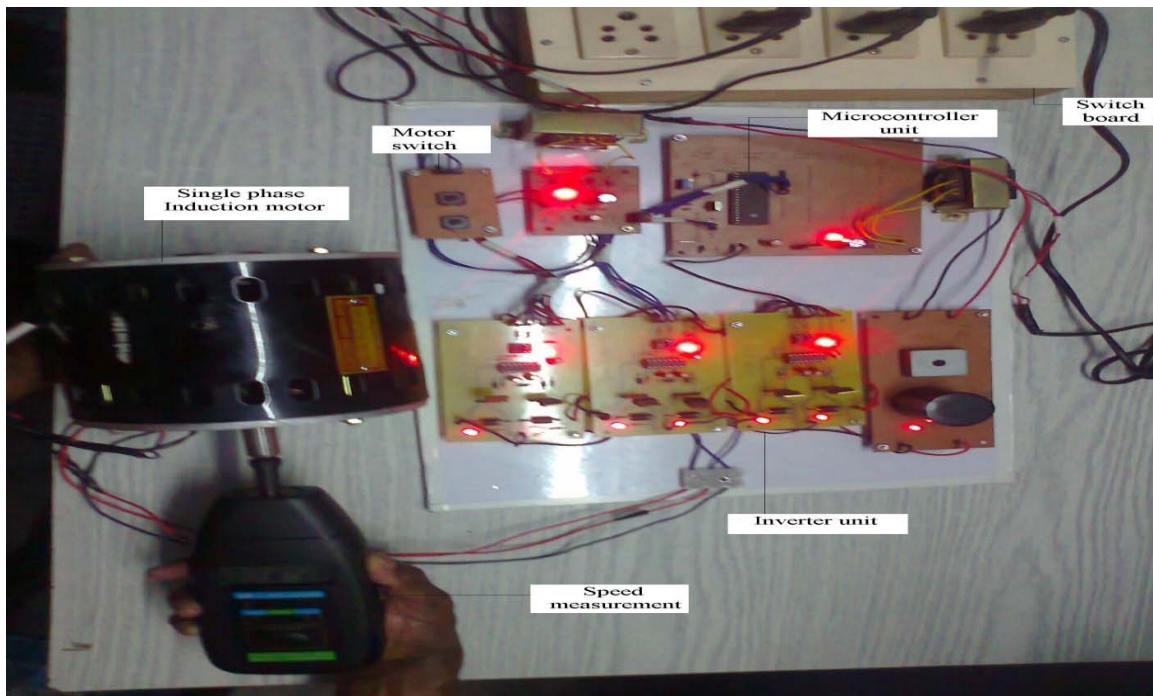

Fig. 6 Hardware with speed measurement

6. SIMULATION RESULTS

Simulation is done using matlab / simulink in three phases. In first phase of sensorless indirect stator field orientation control of SPIM is modeled. In the second phase the space vector modulation is modeled. In third phase the subsystems are modeled.

The pulse to the inverter switches are adjusted using fuzzy controller. The inversion operation is done according to the adjusted value then input given to the motor is in turn adjusted to achieve the reference value.

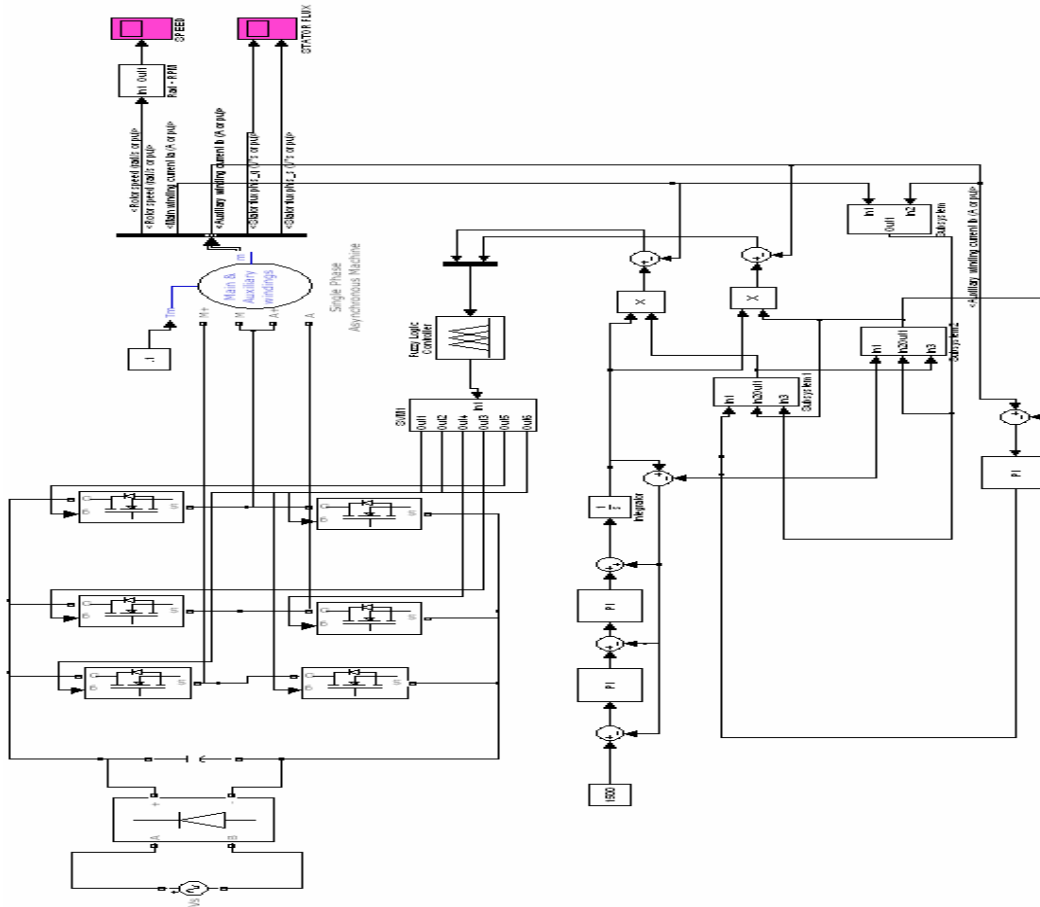

Fig. 7 Modeling of Sensor less ISFOC for SPIM

Fig. 7 shown the diagram of the full view of the sensorless indirect stator field oriented control for single phase induction motor. The speed is calculated without using sensors and is adjusted to the nearest value as possible to the reference value by observing the main winding current and auxiliary winding current. From the fuzzy logic controller the subsystem for space vector modulation is raised. The output of the sub

system is connected to the six terminals of the pulse generator MOSFET switches located in the inverter unit. The output of the fuzzy logic is connected to the voltage controlled oscillator. The stator fluxes are calculated and graphed for the main winding current and the auxiliary winding is shown in Fig. 8. The calculated speed is shown in Fig. 9.

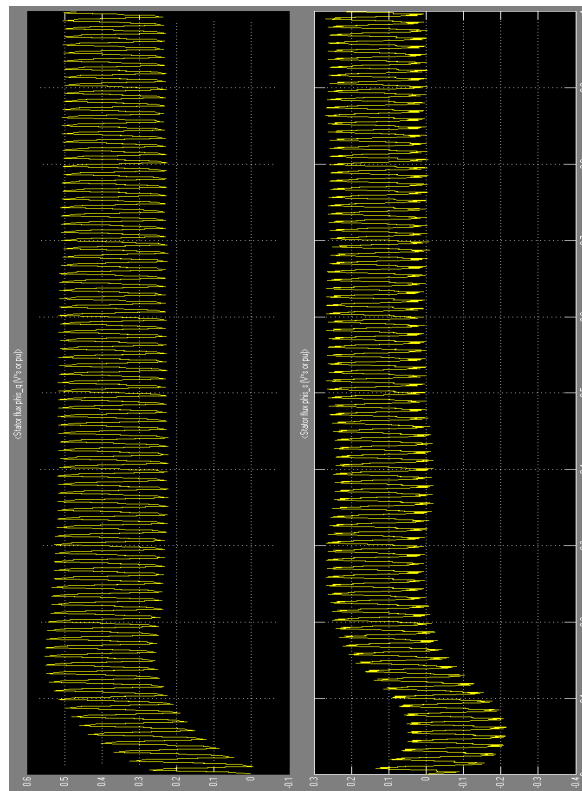

Fig. 8 Stator fluxes

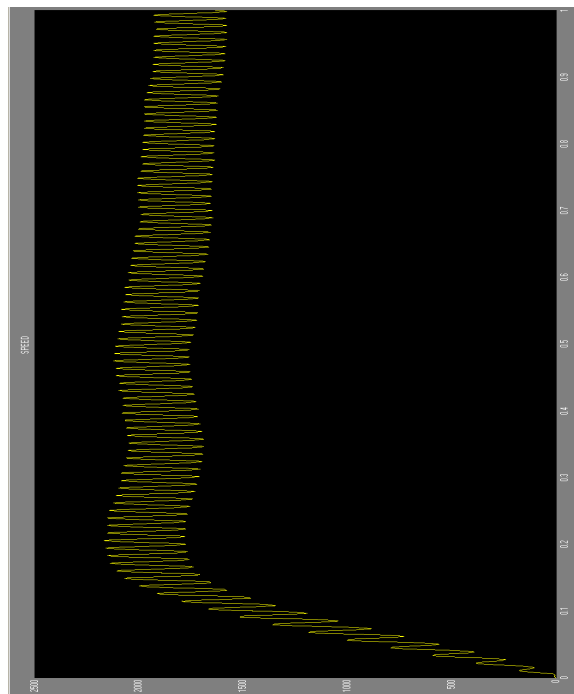

Fig. 9 output speed

7. CONCLUSION

In this paper a new approach have been proposed for sensorless indirect stator field orientation control for single phase induction motor fed by PWM inverter and verified by experiments. The sensors are removed and the speed is calculated,

controlled and adjusted by microcontroller using fuzzy logic. The speed is calculated by the system and compared with the reference value to estimate the limited value to adjust he phase angle of the inverter switch. At very low and zero speed sensorless speed ISFOC of SPIM drive is very

sensitive. The fuzzy logic used here has the advantages like wider range of current limits and faster transaction. The use of DSP processor increases the cost of the system. To overcome that the microcontroller to control the algorithm is used here. The simulation has been done using MATLAB/SIMULINK software and the wave forms were obtained through it. In future it is possible to adapt some high performance control strategies for a single phase motor drive system.

REFERENCES

- [1] M.R. Correa, C.B.Jacobina, A.M.N.Lima, and E.R.C.da silva, "Rotor-flux-oriented control of a single phase induction motor drive" IEEE Trans. Ind. Electron., vol. 47, no.4, pp. 832-841, Aug.2000.
- [2] M.Chomat and T.A.Lipo, "Adjustable-speed single phase IM drive with reduced number of switches", IEEE Trans. Ind. Appl.,vol. 39, no.3, 819-825, May/Jun.2003.
- [3] D.H.Jang and D.Y.Yoon, "Space vector PWM techniquefor two phase inverter fed two phase induction motor", IEEE Trans. Ind., Appl.,vol. 39, no.2, pp. 542-549, Mar/Apr.2003.
- [4] M.R. Correa, C.B.Jacobina, A.M.N.Lima, and E.R.C.da silva, "Vector control strategies for single phase induction motor drive system" IEEE Trans. Ind. Electron., vol. 51, no.5, pp. 1073-1080 Oct.2004.
- [5] M.A.Jabbar, A.M. Khambadkone, and Z.Yanfeng, "Space vector modulation in a two phase induction motor drive for constant power operation", IEEE Trans. Ind. Electron., vol. 51, no.5, pp. 1081-1088 Oct.2004.
- [6] S.Reicy and S.Vaez-zadeh, "Vector control of single phase induction machine with maximum torque operation", in Proc. ISIE, 2005, vol.3, pp. 923-928.
- [7] R.Cardenas, R.Pena, J.Clare, G.Asher, and J.Proboste, "MARS observers for sensorless control of doubly fed induction generators", IEEE Trans. Power Electron., vol. 23, no.3, pp. 1075-1084 May.2008.
- [8] M.Boussak and K.Jarray, "A high performance sensorless indirect stator flux oriented control of induction motor drive", IEEE Trans. Ind. Electron., vol. 53, no.1, pp. 41-49, Feb. 2006.
- [9] S.Vaez-zadeh and A.Payman, "Design and application of speed estimation for single phase induction motors", in Proc.EPE, Toulouse, France, pp.1-10, 2003.
- [10] A.sundaram and Dr.G.P.Ramesh, "A Low Cost Bldc Motor Drive With Sensor Less Speed Estimation And Minimum Torque Ripple Powered From Photo-Voltaic Source Fed SI-Qzs Inverter", Vol. 8, No. 3, pp.248-254, July-September 20, Journal of Engineering and Applied Sciences 12 (11): 2845-2854, 2017.