



# VEHICLE TRACKING SYSTEM USING GPS AND AURDUINO CONTROLLER

Himabindu<sup>1</sup>, Vanusha<sup>2</sup>, M.Swathi<sup>3</sup>, R.Arabhi<sup>4</sup>, D.Narendhar Singh<sup>5</sup>

<sup>1,2,3,4</sup> Anurag Group of Institutions, Hyderabad.

<sup>5</sup>Asso.Prof, Anurag Group of Institutions, Hyderabad

## Abstract

Initially the GPS continuously takes input data from satellite and stores the latitude and longitude values in AT89S52 microcontroller's buffer. To track the vehicle, we send a message to GSM device, by which it gets activated. It parallelly deactivates the GPS with the help of relay. Once GSM gets activated it takes the last received latitude and longitude position values from the buffer and sends the message to a particular number or laptop which is predefined in the program. Once messages has been sent to the predefined device the GSM gets deactivated and GPS activated. This project presents an automotive localization system using GPS and GSM-SMS services. The system permits localization of the automobile and transmitting the position of the owner on his mobile phone as a short message (SMS) at his request.

## 1. INTRODUCTION

Vehicle tracking system's main aim is to give security to all vehicles. This is improved security system for vehicles. The latest like GPS are highly useful now a days, this system enables the owner to observe and track his vehicle and find out vehicle movement and past activities of vehicle. This new technology, popularity called vehicle tracking Systems which created many wonders in the security of the vehicle. This hardware is fitted onto the vehicle in such a manner that is not visible to anyone who is inside or outside of the vehicle. Thus it is used as a covert unit which continuously or by any interrupt to the system, sends the location data to a monitoring unit. When a request by user is sent to the number at the modem, the system automatically sends a return reply to that

particular mobile indicating the position of the vehicle in terms of latitude and longitude. A Program has been developed which is used to locate the exact position of the vehicle on a short message.

The proposed system is used for positioning and navigating the vehicle with an accuracy of 10 m. The Exact location is indicated in the form of latitude and longitude .The system tracks the location of particular vehicle and sends to users mobile in form of data and also to microcontroller. The arrived data, in the form of latitude and longitude is used to locate the Vehicle and also we can see the output on the LCD.

It is mainly a benefit for the companies which are based on transport system. Since it can show the position of all vehicles in real time, so that they can create the expected data accordingly.

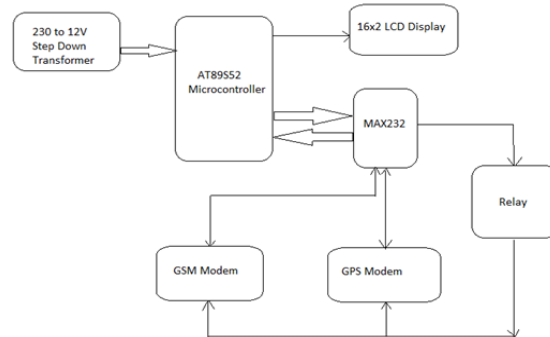

Fig.1 Block diagram

## 2. LITERATURE SURVEY

Vehicle Tracking System proposal allows the organizations to track real-time information about their proposed vehicle during travel. The system contains single android mobile that is equipped with GPS and GSM modems along

with processor that is installed in the vehicle. During vehicle motion its location update can be continuously reported to a server using GPRS service [1].

Vehicle Tracking Device(VTD) is a tracking device Focusing on vehicles that use Short Message Service(SMS). VTD will give information of location coordinates to mobile phone whenever there is a request for it through the SMS. The integrated Global Positioning System and Global System for Mobile Communication(GPS-GSM) is used to track vehicle using application such as Waze or Google maps.VTD is an integration of both hardware and software. The hardware components include a microcontroller, Arduino Uno board, sim-card slot, voice-alarm module, signal antenna, battery and mobile phone as well as a program controller interface. The prototype of VTD has been successfully developed to track vehicle using GPS via SMS [2].

An efficient vehicle tracking system is implemented For monitoring the movement of any equipped vehicle from any location at any Time. With the help of Global Positioning System(GPS), Global System for Mobile Communication(GSM) modem and microcontroller are embedded with an aim of enabling users to locate their vehicles with ease and in a convenient manner. This System provides the facility to the user to track their vehicle remotely through the Mobile network. This paper presents the development of vehicle tracking systems hardware prototype and GUI application for displaying the actual position of the vehicle [3].

Passive systems were developed to support navigation and tracking for location based applications. But now Automatic Vehicle Location (AVL) systems are developed and deployed in numerous environments. These systems are capable of transmitting vehicle's location information in real time. In these systems,the device installed in the vehicle can transmit location information in real time to a remote data Centre, instead of storing into local storage, using some radio network [4].

In our work, the vehicle tracking system comprises of key components such as the Global Positioning System(GPS), Global System for

Mobile Communication(GSM) and At89s52 microcontroller. The device is fitted into the vehicle in such a way that it can neither be seen to anyone inside or outside the vehicle. When a request is sent by the user to the GSM module then the system sends a quick reply to that particular mobile indicating the position of the vehicle in terms of latitude and longitude.

### 3.HARDWARE AND SOFTWARE REQUIREMENTS

#### 3.1 Hardware components:

##### 3.1.1 GSM

The GSM system was designed as a second generation cellular phone technology. One of the basic aims was to provide a system that would enable greater capacity to be achieved than the previous first generation analogue systems. By adopting this technique more users could be accommodated within the available bandwidth.



Fig: 1 GSM Module

This modem works with a set of AT commands. Then AT, UART are basically fed through UART protocols which are also known as serial data. This AT command is fed through DB9 female connector which follows RS232 standard where the controller is 5V TTL levels. It consist of pins mainly GND,Tx,Rx ,Vin where Rx is connected to Tx of controller pin and Tx is connected to Rx of controller pin and a common GND is given.Vin is given to supply voltage and adapter is connected to the DC socket of 12V with minimum 2A of current rating.This modem consist of 3 indicators LED's namely status,power,networkLED. GSM pins TX and RX are connected to microcontroller serial ports. A fully functional SIM card is placed on the SIM card slot provided on bottom of the board, which is used for sending and receiving SMS messages.

In our work, we used GSM modem with SIM 900A which works on frequencies 900/1800 MHZ. This modem has RS232 interface,which

allows us to connect pc as well as microcontroller with RS232 chip(MAX232). Using this we will receive exact location of the vehicle via SMS to a registered mobile number.

### 3.1.2 GPS (GLOBAL POSITIONING SYSTEM)

AGPS navigation device is a device that accurately calculates geographical location by receiving information from GPS satellites. The Global Positioning System (GPS) is a satellite-based navigation system made up of a network of a minimum of 24, but currently 30, satellites placed into orbit by the U.S. Department of Defense.

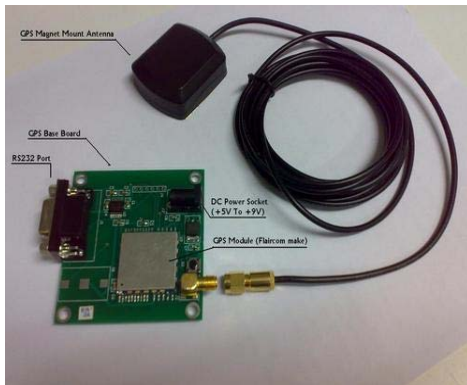

Fig.:2 GPS Module

GPS satellite transmits band signals that are modulated by several courses. The GPS segment consists of 24 satellites in medium of earth orbit at nominal attitude of 70,000200km. The position of GPS is found by trilateration which is the process of determining absolute or relative locations of points by measurement of distances

### 3.1.3 MICROCONTROLLER

A microcontroller is a computer on a chip. It is an integrated chip that is usually a part of an embedded system. It is a microprocessor that is meant to be more self-contained, independent and yet function as a tiny, dedicated computer. It lays emphasis on high integration, low power consumption, self-sufficiency and cost effectiveness.

It is typically designed using the CMOS (complementary metal oxide semiconductor) technology and has the following features:

- CPU
- Discrete input and output pins
- Serial input/output ports(UARTs)
- Peripherals such as timers, counters

- RAM, ROM, EPROM, Flash Memory(EEPROM)
- Clock generator
- May include analog to digital converters

In-circuit programming and debugging support  
Microcontroller communicates with the help of serial communication. First data is taken from the GPS receiver and then sends the information to the owner in the form of SMS with help of GSM modem.

The code is written in the internal memory of Microcontroller i.e. ROM. With help of instruction set it processes the instructions and it acts as interface between GSM and GPS with help of serial communication. In our project we used **ATMEL 89S52** microcontroller.

### ATMEL 89S52

ATMEL 89s52 is a low power, high performance CMOS 8 bit microcomputer with 4K bytes of flash programmable and erasable read only memory (PEROM).The device is manufactured using Atmel's high density, nonvolatile memory technology and is compatible with industry standard MCS-51 instruction set. It provides highly flexible and cost effective solution to many embedded control applications.

#### Port 0 (PIN 32-39)

Port 0 is an 8-bit open drain bidirectional I/O port. As an output port, each pin can sink eight TTL inputs. When 1s are written to port 0 pins, the pins can be used as high-impedance inputs. Port 0 can also be configured to be the multiplexed low-order address/data bus during accesses to external program and data memory. In this mode, P0 has internal pull-ups. Port 0 also receives the code bytes during Flash programming and outputs the code bytes during program verification. External pull-ups are required during program verification.

#### Port 1 (PIN 1-8)

Port 1 is an 8-bit bidirectional I/O port with internal pull-ups. The Port 1 output buffers can sink/source four TTL inputs. When 1s are written to Port 1 pins, they are pulled high by the internal pull-ups and can be used as inputs. As inputs, Port 1 pins that are externally being pulled low will source current (IIL) because of the internal pull-ups. In addition, P1.0 and P1.1 can be configured to be the timer/counter 2 external count input (P1.0/T2) and the timer/counter 2 trigger input (P1.1/T2EX), respectively, as

shown in the following table. Port 1 also receives the low-order address bytes during Flash programming and verification.

#### **Port 2 (PIN 21-28)**

Port 2 is an 8-bit bidirectional I/O port with internal pull-ups. The Port 2 output buffers can sink/source four TTL inputs. When 1s are written to Port 2 pins, they are pulled high by the internal pull-ups and can be used as inputs. As inputs, Port 2 pins that are externally being pulled low will source current (IIL) because of the internal pull-ups.

#### **Port 3 (PIN 10-17)**

Port 3 is an 8-bit bidirectional I/O port with internal pull-ups. The Port 3 output buffers can sink/source four TTL inputs. When 1s are written to Port 3 pins, they are pulled high by the internal pull-ups and can be used as inputs. As inputs, Port 3 pins that are externally being pulled low will source current (IIL) because of the pull-ups. Port 3 receives some control signals for Flash programming and verification.

#### **RST (PIN 9)**

Reset input. A high on this pin for two machine cycles while the oscillator is running resets the device. This pin drives high for 98 oscillator periods after the Watchdog times out. The DISRTO bit in SFR AUXR (address 8EH) can be used to disable this feature. In the default state of bit DISRTO, the RESET HIGH out feature is enabled.

#### **ALE/PROG (PIN 30)**

Address Latch Enable (ALE) is an output pulse for latching the low byte of the address during accesses to external memory. This pin is also the program pulse input (PROG) during Flash programming.

normal operation, ALE is emitted at a constant rate of 1/6 the oscillator frequency and may be used for external timing or clocking purposes. If desired, ALE operation can be disabled by setting bit 0 of SFR location 8EH. With the bit set, ALE is active only during a MOVX or MOVC instruction.

#### **PSEN (PIN 29)**

Program Store Enable (PSEN) is the read strobe to external program memory. When the AT89S52 is executing code from external program memory, PSEN is activated twice each machine cycle, except that two PSEN activations are skipped during each access to external data memory.

#### **EA/VPP (PIN 31)**

External Access Enable. EA must be strapped to GND in order to enable the device to fetch code from external program memory locations starting at 0000H up to FFFFH. Note, however, that if lock bit 1 is programmed, EA will be internally latched on reset. EA should be strapped to VCC for internal program executions. This pin also receives the 12-volt programming enable voltage (VPP) during Flash programming.

#### **XTAL1 (PIN 19)**

Input to the inverting oscillator amplifier and input to the internal clock operating circuit.

In our project AT89s52 microcontroller is used for interfacing to various hardware peripherals. Which is continuously monitor a moving Vehicle and report the status of the Vehicle. For doing so an AT89S52 microcontroller is interfaced serially to a GSM Modem and GPS Receiver. A GSM modem is used to send the position (Latitude and Longitude) of the vehicle from a remote place. The GPS modem will continuously give the data i.e. the latitude and longitude indicating the position of the vehicle. The GPS modem gives many parameters as the output, but only the NMEA data coming out is read and displayed on to the LCD. The same data is sent to the mobile at the other end from where the position of the vehicle.

#### **3.1.4 LCD(liquid crystal display)**

##### **(i) Introduction**

A liquid crystal display (LCD) is a thin, flat display device made up of any number of color or monochrome pixels arrayed in front of a light source or reflector. Each pixel consists of a column of liquid crystal molecules suspended between two transparent electrodes, and two polarizing filters, the axes of polarity of which are perpendicular to each other.

##### **(ii) Features**

- (1) Interface with either 4-bit or 8-bit microprocessor.
- (2) Display data RAM.
- (3) 80x8 bits (80 characters).
- (4) Character generator ROM.
- (5) 160 different 5 X7 dot-matrix character patterns.
- (6) Character generator RAM.
- (7) 8 different user programmed 5 X7 dot-matrix patterns.

- (8) Display data character generator RAM may be accessed by the microprocessor.
  - (9) Numerous instructions.
  - (10) Clear Display, Cursor Home, and Display ON/OFF, Cursor ON /OFF.
- Data can be placed at any location on the LCD.

**(iii) PIN DESCRIPTION**

Most LCDs with 1 controller has 14 Pins and LCDs with 2 controller has 16 Pins (two pins are extra in both for back-light LED connections)

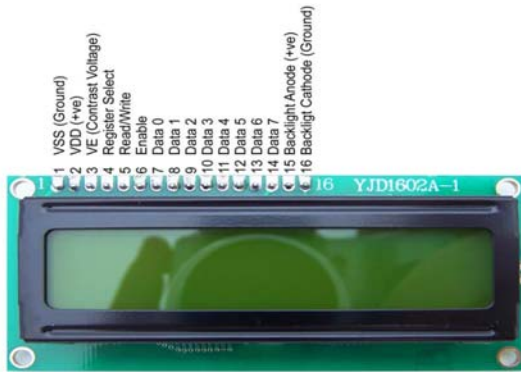

**Fig:3 LCD**

PIN	SYMBOL	FUNCTION
1	Vss	Power Supply(GND)
2	Vdd	Power Supply(+5V)
3	Vo	Contrast Adjust
4	RS	Instruction/Data Register Select
5	R/W	Data Bus Line
6	E	Enable Signal
7-14	DB0-DB7	Data Bus Line
15	A	Power Supply for LED B/L(+)
16	K	Power Supply for LED B/L(-)

**CONTROL LINES**

**EN**

Line is called "Enable." This control line is used to tell the LCD that you are sending it data. To send data to the LCD, your program should make sure this line is low (0) and then set the other two control lines and/or put data on the data bus. When the other lines are completely ready, bring EN high (1) and wait for the minimum amount of time required by the LCD datasheet (this varies from LCD to LCD), and end by bringing it low (0) again.

**RS**

Line is the "Register Select" line. When RS is low (0), the data is to be treated as a command or special instruction (such as clear screen, position cursor, etc.). When RS is high (1), the data being sent is text data which should be displayed on the

screen. For example, to display the letter "T" on the screen you would set RS high.

**RW**

Line is the "Read/Write" control line. When RW is low (0), the information on the data bus is being written to the LCD. When RW is high (1), the program is effectively querying (or reading) the LCD. Only one instruction ("Get LCD status") is a read command. All others are write commands, so RW will almost always be low.

In our project we used 16x2 LCD to display latitudes and longitude co-ordinates from the satellites about the location of the vehicle .the output is displayed by using two control pins of LCD i.e. pin5(R/W) and pin6 (E) This refers to the controller chip which receives the data from an external source and communicates directly with LCD and displays the latitude and longitudes position/Coordinates on LCD.

**3.1.7 RELAY**

A relay is an electrically operated switch. Relays are used where it is necessary to control a circuit by a separate low-power signal, or where several circuits must be controlled by one signal. The relay used for this project is 12V C/O relay.

**(i)C/O RELAY OPERATION**

A Relay is simply a device which makes its contacts change when the current flowing through its coil exceeds pick up value. A Relay may have NO and NC contact which can be used as per convenience.

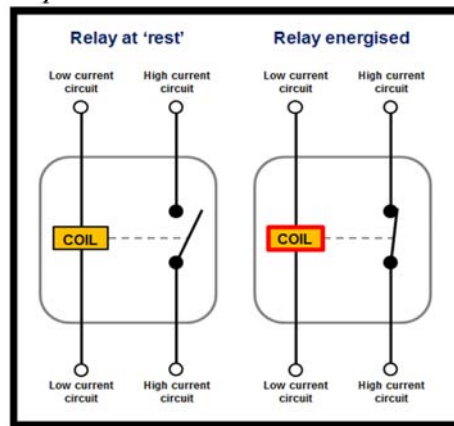

**Fig: 4 Relay internal connections**

Vehicle tracking relies both on the Global Positioning satellites (GPS) and a cellular system. A tracking module in the vehicle continuously picks up the GPS coordinates that indicate the real-time location of the vehicle.

In our project,we used relay to activate the GSM modem and simultaneously deactivate GPS when a message is sent.

**4. PROPOSED METHOD**

**4.1 CONNECTIONS**

- a. The LCD is connected to 6<sup>th</sup>, 7<sup>th</sup>, 8<sup>th</sup> pins of first port and 22, 23, 24,25,26,27 pins of third port of Microcontroller.
- b. The 9<sup>th</sup>, 10<sup>th</sup> and 12<sup>th</sup> pins of RS232 is connected to 5<sup>th</sup>, 10<sup>th</sup> and 11<sup>th</sup> pin of Microcontroller.
- c. The 13<sup>th</sup> and 14<sup>th</sup> pin of RS232 is connected to GPS module.
- d. The 7<sup>th</sup> and 8<sup>th</sup> pin of RS232 is connected to GSM modem.
- e. Remaining pins of RS232 are connected to resistors and relay.
- f. The power supply is connected to 40<sup>th</sup> and 31<sup>st</sup> pin of Microcontroller.

**4.2 CIRCUIT DIAGRAM**

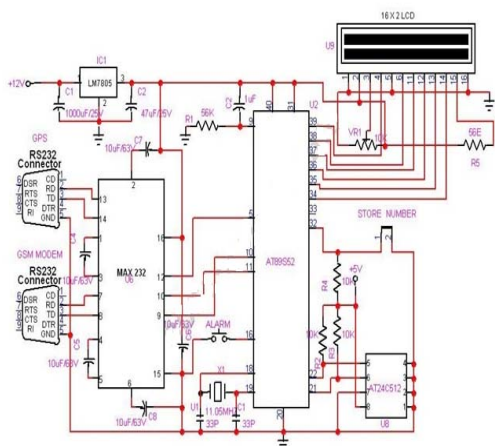

**Fig 5 circuit diagram**

**4.3 WORKING**

This project mainly works on GPS and GSM systems. Vehicle is traced by using information from satellite systems and sends to GSM systems. Vehicle and users are connected initially by using GSM network. Users will send message to moving vehicle for connectivity, hardware mounted on vehicle reacts to message and send conformation message to user and them if the message is valid one then GPS modem is initialized and requested for location. The latitude and longitude values are compared with the values stored in the memory and corresponding location name is given to the controller which in turn uses GSM/GPRS to send the location name by means of short message service back to user.

**4.4 ALGORITHM**

- Step1:** start
- Step2:** Initialize the GPS and GSM
- Step3:** Message TRACK is sent to GSM
- Step4:** GSM gets activated.
- Step5:** If yes, microcontroller processes and activates GPS, else return to step2
- Step6:** GPS gets activated.
- Step7:** If yes, get coordinates from the satellite, else return to step2
- Step8:** Microcontroller process the information
- Step9:** Send latitude, longitude and alert via SMS
- Step10:** If yes send the SMS ,else return to step9

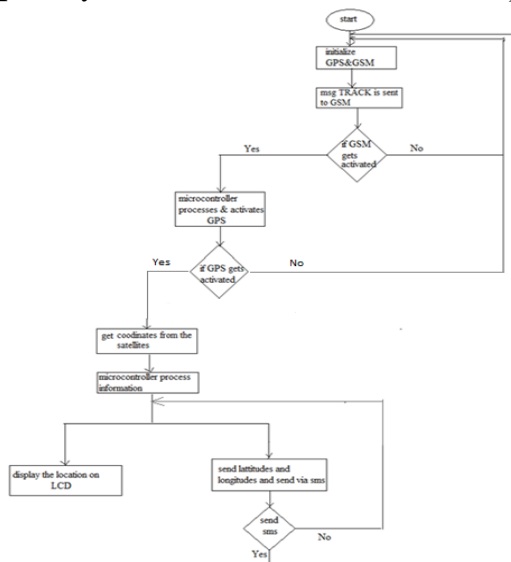

**Fig 7 Flowchart**

**4.5 RESULT**

This system helps send the location of the vehicle to the mobile whenever an sms “TRACK” is sent from mobile to the system. the system sends in the form of latitudes and longitudes, which helps in better scheduling and route planning in short time.



## **5. CONCLUSION AND FUTURE SCOPE**

Vehicle tracking systems becoming increasingly important in large cities and it is more secured than other systems. This technology helps to advance the system of transportation and can be used in many organizations for security purpose and tracking purpose. With GPS tracking systems popping up in cell phones, watches, and shoes, there's no doubt that GPS tracking devices are making their way into all walks of daily life.

### **References:**

- [1] Kamble, S., Godbole, C., Gaikwad, R., Yadav, A.P., Kamble, S., Godbole, C., Gaikwad, R. and Yadav, A.P., 2016. Vehicle Tracking System. *International Journal*, 2, pp.415-419.
- [2] Lee, S., Tewolde, G. and Kwon, J., 2014, March. Design and implementation of vehicle tracking system using GPS/GSM/GPRS technology and smartphone application. In *Internet of Things (WF-IoT), 2014 IEEE World Forum on* (pp. 353-358). IEEE.
- [3] Pham, H.D., Driberg, M. and Nguyen, C.C., 2013, December. Development of vehicle tracking system using GPS and GSM modem. In *Open Systems (ICOS), 2013 IEEE Conference on* (pp. 89-94). IEEE.
- [4] Rohitaksha, K., Madhu, C.G., Nalini, B.G. and Nirupama, C.V., 2014. Android Application for Vehicle Theft Prevention and Tracking System. *International Journal of Computer Science and Information Technologies*, 5(3), pp.3754-3758.
- Qayyum, E., Mohsin, Z. and Malik, J., 2013. *Real-Time Vehicle Tracking System Using GPS & GSM*. Lap Lambert Academic Publishing.