



## **GSM BASED SMART ENERGY METER TO IMPLEMENT BILLING SYSTEM AND TO CONTROL ELECTRICITY THEFT**

Vidyashree M S

Assistant Professor, GSSSIETW, Mysuru, Karnataka

Email:vidyashreems6592@gmail.com

### **Abstract**

**Automatic meter reading (AMR) system give the information of meter reading, power cut, total load used, power disconnect and tempering on request or regularly in particular interval through SMS. This is aim to measure and monitor the electricity consumed by consumers in a locality and transmitting the consumed power to the station as well as issuing the bill of consumed power automatically and online payment is also possible. It is also aims to find the malpractices in the meter. Provider Company with the help of Global system for mobile communication (GSM) network access prepaid energy metering system to control electricity theft. Server station is also served by a GSM module for transmission and reception of data as energy auditing. Constraints are accurate metering, energy theft and implementation of proper tariff as well as billing system. This can be achieved by using Smart Meters. This paper makes the consumer an active part of Energy Management.**

**Key words: SMS; intelligent power automatic meter reading (AMR);GSM networks; prepaid online electricity bill; electricity theft control; tariff; Energy Conservation**

### **INTRODUCTION**

An energy meter is a device which is used to measures the consumption of energy of any residence or other industrial establishment. In Conventional metering system to measure electricity consumption the energy provider company hire persons who visit each house and record the meter reading manually. These meter

readings are used for electricity bill calculation and this bill sent to consumer house by post. In Conventionally metering system people try to manipulate meter reading by adopting various corrupt practices such as current reversal or CT reverse tampers, partial earth fault condition, bypass meter, magnetic interference etc . There is a stark amount of revenue loss being incurred by our country. This metering system becomes very difficult especially in rainy season. If any consumer did not pay the bill, the electricity worker needs to go to their houses to disconnect the power supply. It is in efficient way for measuring power consumption. Power line communication and Zigbee technology also use for meter reading.

The stability and reliability of meter reading data are low of power line communication because the carrier wave signal (power/telephone line) is very easily disturbed by noise. ZigBee devices are extremely limited in resources including processing, memory, and power, short operating range .GSM based automatic meter reading system is a succor. AMR eliminates any possibility of electricity theft.

GSM is a digital mobile telephony system that digitizes and compresses data before sending it. The main advantage of the GSM is its widespread use throughout the world and the use of subscriber identity module (SIM) cards to send short message service (SMS) messages.

Automatic meter reading (AMR) system is an effective way of data collection, that allow substantial saving through the reduction of meter read, greater accuracy, allow frequent reading, improved billing, reduced tempering. It provides better customer services, by sending alert of power cuts and consummation updates.

AMR is an effective mean of data collection that allow substantial saving through the reduction of meter re-read, good data accuracy, allow frequent reading, improved billing and customer service, more timely energy profiles and usage trends updates, and better deployment of human resource. AMR system is very useful for remote area or small villages which are not connected by any means of transport such as an island or remote precinct.

GSM based data collection system can be very swift, accurate and efficient. Prepaid energy meters based on GSM network has been proposed. These meters incorporate the facility of prepaid metering system and remote load control. Also, can be further matured to address the problem of electricity theft. Electricity theft has emerged as a serious problem in power sectors especially

in the developing countries. A huge amount of revenue is lost due to electricity theft. Electricity theft includes tampering meters to show a low meter reading, stealing electricity bypassing a meter, billing irregularities and unpaid bills. Billing irregularities comprise inaccurate meter reading taken by bribed service man and intentional fixing of the bill by office staffs in exchange of illicit payments from the consumer. Different nontechnical and technical methods were proposed in the past to detect electricity pilfering. Nontechnical methods may include inspection of the customers with suspicious load profile. Although periodic inspection can substantially reduce theft, such measure requires large man power and huge labor. Such effort also fails in most cases due to the dishonesty of the staffs.

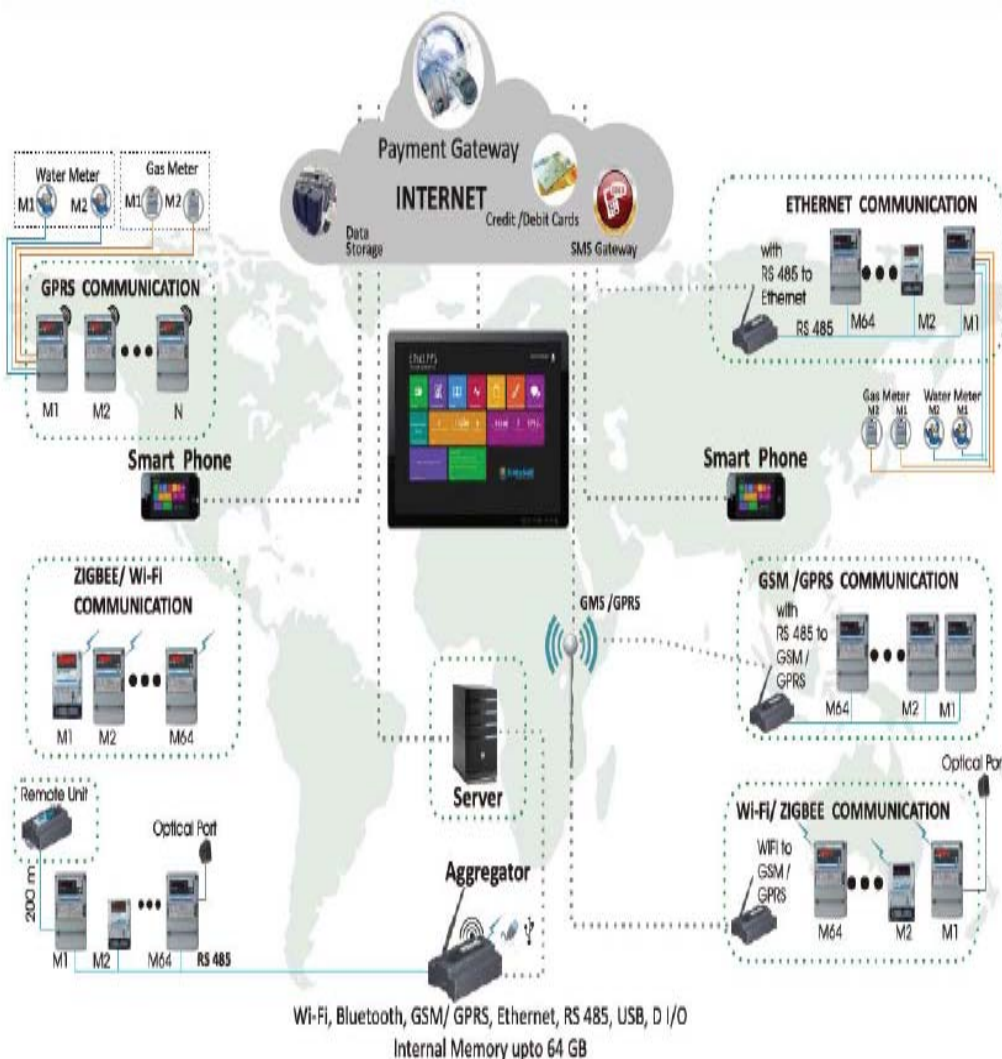

In this paper, it has been proposed a GSM based Automatic meter reading and prepaid energy metering system which deals with different aspects of electricity theft. The proposed system prevents irregularities of billing, reluctance of consumers to pay bills in time, meter tampering and bypassing

### EXISTING SYSTEMS

In the existing system, electricity meter reading for electricity usage and billing is done by human workers from home to home and building to buildings. This requires huge number of workers and long working time to achieve complete area data collection and billing. Human workers billing are prone to reading error as sometime the houses electric meter is placed where it isn't easily accessible. Labor billing job is sometime also restricted and slowed down by bad environmental condition. Paper billing has the tendency of losing in the post box. The increased development of residential housing and industrial buildings in the developing country such as for example, India require more human workers and longer working hours to complete the usage reading task. These increases the energy provider operation costs for meter reading.

### TECHNOLOGY UTILISED (GSM)

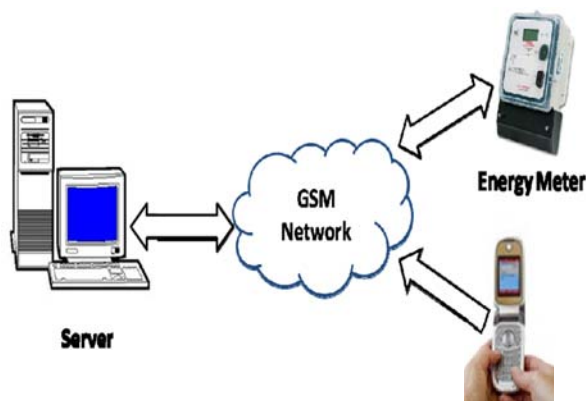

**Fig : 2 : Overview of the proposed GSM based AMR and prepaid metering system**

### GSM modem

Quad-band intelligent GSM/GPRS modem suitable for long duration data transmission. To implement AMR system a GSM modem is connected to a microcontroller which would transmits data from a meter to cell phone and also receive command from cell phone to energy

meter. The modem will send unit or pulses (power consumption) on a regular interval or on a request. AT commands set which stands for attention terminal are used by energy meter to communicate with the GSM Modem

The communication between the server, mobile application and the energy meter is done through the GSM module by Short Message Service (SMS). If the command for reading current consumption arrived at the GSM module, the current value of the unit is send to a fixed mobile number which will be registered with the meter. It can also cut the power supply by sending SMS to the GSM module connected with the energy meter from the same registered number. After receiving the message for disconnect the power, reconnecting also done with the help of the same module. This circuit also provides alerts about over usage, energy theft. Over usage is calculated by comparing the usage in a fixed time period and theft detection is done by monitoring the usage after the Theft check button is pressed.

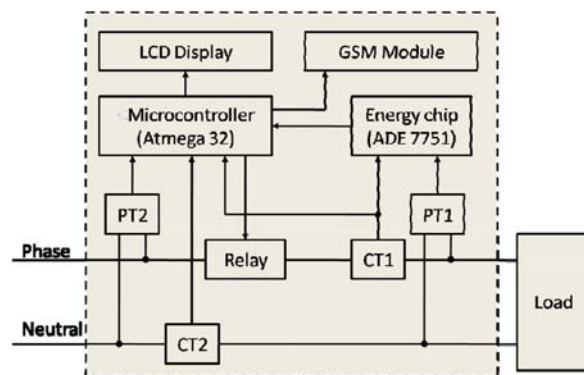

**Fig : 3 : Block diagram of the GSM based smart meter.**

Here an android application is developed for consumers, so that they can login to it using a consumer id and password provided by the administrator. The Consumer can request the meter readings by simply pressing a button in the android application. The bill amount to be paid for power consumption is automatically generated in the App. The consumer is provided with the facility to remote disconnect and reconnect to mains. Another feature is that; the consumer can make the online payment of electricity bill through the App. With the help of a GSM module, notifications about over usage at peak time and detection of any malpractices are also provided in the android App. The consumer

can register complaints and can also cut the power supply for unwanted time. The users get warnings or notifications to the consumer about consumption, payment date etc.

Energy provider side is a web portal where the administrator can add users, update cost per unit, filter unpaid users, cut the power supply. The administrator assigns a user id and password for the user for accessing the mobile application. The readings from the energy meter will be updated in the energy provider server with the help of GSM module. After generating bills, the admin can see the users with payment status. If they are not paid, then the administrator can disconnect the power supply to the corresponding user by sending Messages to the energy meter.

### PROPOSED SYSTEM (AMR)

Smart Meters are an electronic measurement devices used by utilities to communicate information for billing customers and operating their electric systems. The combination of an electronic meter with two-way communications technology for information, monitor, and control is commonly referred to as Advanced Metering infrastructure (AMI). Previous systems, which utilized one-way communications to collect meter data were referred to as AMR (Automated Meter Reading) Systems. AMI has developed over time, from its roots as a metering reading substitute (AMR) to today's two-way communication and data system. The evolution from AMR to AMI is shown in Table:1 with lists of stakeholders and benefactors for each step in Smart Meter evolution. An Automatic Meter Reading (AMR) system equipped with advanced features like two-way communication, Time-Of-Day (TOD) tariff, etc. will address the problems of manual collection of meter data, energy deficit during peak hours and opens a channel for the consumers to participate in energy conservation. With development in technologies in the fields of communication and information technology, a wide variety of AMR and smart meters has been developed. A smart meter is an AMR with two-way communication infrastructure. Smart meters has been designed for various features like remote monitoring of energy consumptions, remote turn ON/OFF power supply, remote detection of energy theft, with time varying

pricing system, remote fault detection, capable of monitoring power quality etc. Developments in information management and remote monitoring technology can play a vital role in energy management. Smart meter reading cooperate both utilities and consumers in power management, giving them detailed information about power consumption. This article proposes the advance features & application method of a smart metering system compared over traditional Energy meters which can address issues in the power distribution. This paper also makes the consumer an active part of Energy Management duly monitoring the various parameters like voltage, current, power factor etc., directly in the Smart meter, (or) in the PC through RS 485 and necessary precautionary measures can be taken to improve power factor, and to minimize energy loss.

### DESIGN OF AMR

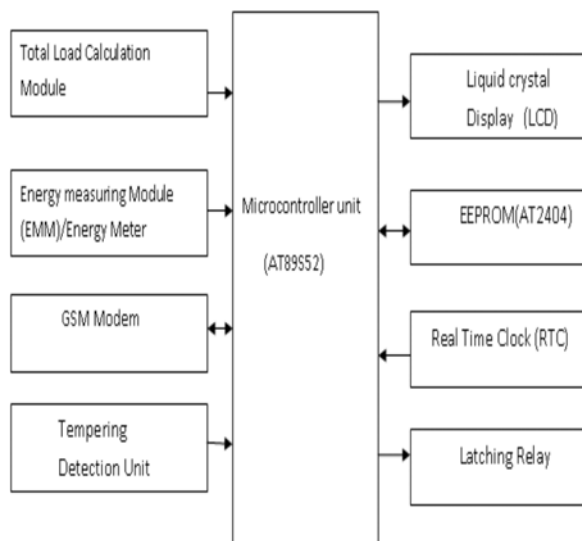

**Fig : 4 : Block diagram of GSM based AMR**

Figure 4. shows a block diagram of AMR. AMR continuously monitor and record the energy meter. This can be achieved by using microcontroller unit and is interface with energy meter and LCD. Microcontroller unit continuously monitor the energy meter and pulses display on LCD. That gives the information of power consumption in a house. For the information of power cut microcontroller unit

is interface with RTC clock and relay. For communication purpose microcontroller unit is also interfaced with GSM modem.

**MEASURES FOR CONTROLLING ELECTRICITY THEFT**

***I. Protection against Shorting the Phase Line and Disconnecting the Neutral Line***

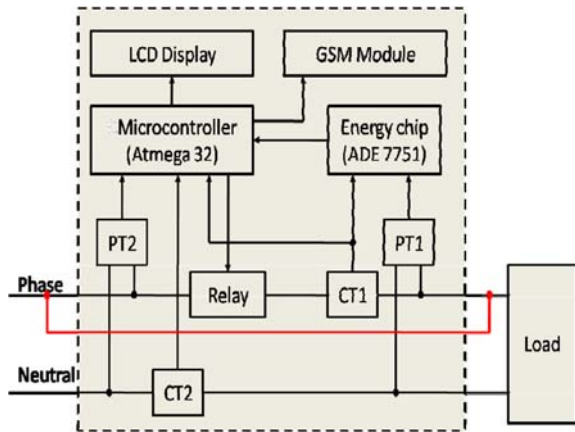

**Fig : 5 : To bypass conventional meter is shorting the phase line**

If only one current transformer is used and connected in the phase line, then the energy measured by the meter will be zero. Another method of bypassing is to disconnect the neutral line as depicted in Fig.6

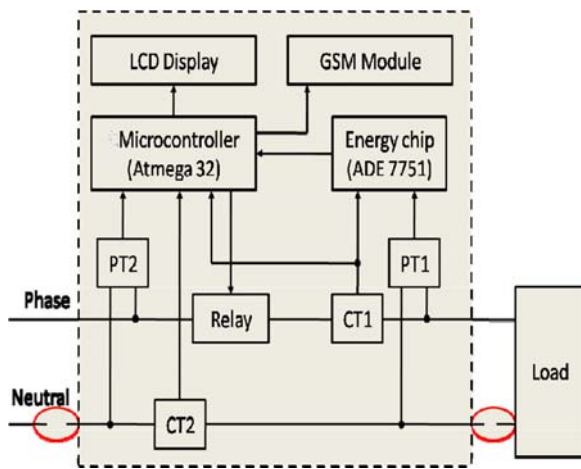

**Fig: 6 :Bypassing- to disconnect the neutral line**

In this case the potential measured by the potential transformer will be zero and no energy consumptions will be registered by the meter. To prevent these bypassing, two current transformers are used separately in the phase and neutral line in our proposed system. The output

voltages of CT1 and CT2 are provided to the ADC inputs of the microcontroller. If the phase line is shorted or the neutral line is disconnected then there will be difference between the output voltages of CT1 and CT2. The microcontroller compares the voltages of CT1 and CT2 and if any significant difference is found, it disconnects the load immediately using the relay. In such events the energy meter warns the server of the corresponding bypassing through SMS. Upon receiving SMS, the server blocks the energy meter and informs the authority. The authority can take legal action against the consumer.

***II. Protection against Whole Meter Bypassing***

In extreme cases the whole meter can be bypassed as shown in Fig.7 As a result the meter will detect no energy consumption. To prevent this kind of theft, our proposed energy meter takes several steps. The output of PT2 is converted to 5V dc and is given to the interrupt pin of the microcontroller. When the whole meter is bypassed PT2 detects no voltage and an interrupt is sent to the microcontroller. The energy meter then requests the power status of the area, where the meter is located, to the server. If the server confirms that the power supply is available in that area, then the meter immediately disconnects the load and informs the server of the electricity theft. During the whole operation backup from a rechargeable battery is available.

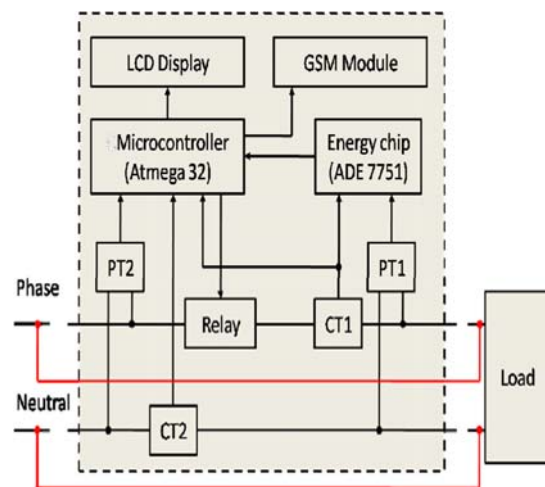

**Fig : 7 : Bypassing of whole meter**

***III. Control of Electricity Theft using Observer Meter***

Electricity pilfering may occur in the form of unregistered load as shown in Fig. 8

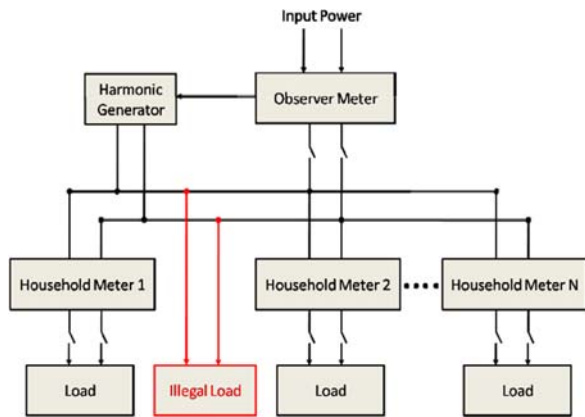

**Fig: 8 : Unregistered load or Illegal load**

Also radio frequency devices may be used to influence the accuracy of the device. There also exists many named and unnamed engineered ways for electricity theft. These types of theft cannot be detected and controlled using single household meter. To detect such unaccounted theft, an observer meter is used in the proposed system. The observer meter shown in Fig. measures the total energy consumption of several households at specified time intervals. This type of meter can be installed for example outside an apartment building. In that case, this will measure the energy consumed by all the flats in that apartment building. The household meters inform the observer meter of their corresponding measured units through SMS. If the two values differ by a considerable amount, the central meter detects electricity theft. Since, individual meter readings are available to the central meter, it can find out the possible households where theft has occurred on the basis of zero or low energy consumption. The central meter reports the possible locations of theft to the server using SMS. The authority can send technical staffs to check the reported households and can detect the particular dishonest consumer.

#### ADVANTAGES AND FUTURE SCOPE

The system designed reduces the efforts of manual data collection of energy meter. Also, data which is received at service provider side is easy to manipulate for bill generation and other such tasks. With this system we can collect the reading as well as control the supply to the user. With addition of software at service provider side, the customer can be informed of current meter reading, bill for current cycle, status of the line and other parameters to the customer with message. The technology used in energy meter is expanding to the power distribution

transformers. So that it can cut the power supply from anywhere in case of any emergency or maintenance, find areas with power distribution failure.

Smart metering system is useful to both utility Provider and consumers. An intelligent circuit which detects theft and generate a switching pulse on detection of theft can be designed and integrated with the system. An apt tariff system and theft detection circuitry can be integrated with the proposed smart meter design. This smart energy meter system takes the advantage of existing GSM network that have full coverage of all housing and industrial area all over the country which lead to low implementation cost, and it is simple to install. The provides reliable, effective and efficient automatic meter reading, online billing, and notification through the use of GSM network and android application, thus reduce human effort in meter reading and this method is very economical and time saving.

#### CONCLUSION

In this paper, it has been proposed a smart meter which takes advantage of the GSM network that has virtually access to every household and area across different countries. GSM based energy meter is easy to installation and beneficial for both energy provider and consumer. AMR not only solve the problem of manual meter reading but also provide additional feature such as power disconnect due to outstanding dues, power reconnect after pay dues, power cut alert, tempering alert. AMR also gives the information of total load used in a house on request at any time. It sends a SMS alert to energy provider company whether a person using more than specify limit of load. The statistical load used and profile can help customer manage their energy consumption. GSM communication not only implements the idea of prepaid consumption of electricity but also facilitates the utilities to control energy theft using our smart energy meter. In this system, the information of electricity theft is directly reported to the central authority. Therefore, utilities can take immediate legal action against the accused consumer and hence control electricity theft to a great extent. The proposed meter is thus highly useful for power utilities for reducing electricity pilfering and ensuring revenue collection. This makes the consumer an active part of Energy Management

## REFERENCES

- [1] Abhinandan Jain, Dilip Kumar, Jyoti Kedia “**Design and Development of GSM based Energy Meter**”, *International Journal of Computer Applications (0975 – 888) Volume 47– No.12, June 2012*
- [2] Nabil Mohammad\*, Anomadarshi Barua and Muhammad Abdullah Arafat “**A Smart Prepaid Energy Metering System to Control Electricity Theft**”, *2013 International Conference on Power, Energy and Control (ICPEC) 978-1-4673-6030-2/13/\$31.00 ©2013 IEEE*
- [3] G.Vani, V.Usha Reddy “**Application of Smart Energy Meter in Indian Energy Context**” *IOSR Journal of Electrical and Electronics Engineering (IOSR-JEEE) e-ISSN: 2278-1676,p-ISSN: 2320-3331, Volume 10, Issue 3 Ver. III (May – Jun. 2015), PP 07-13*
- [4] Diya Elizabeth Paul , Prof . Alpha Vijayan “**Smart Energy Meter Using Android Application And Gsm Network**” *International Journal Of Engineering And Computer Science ISSN:2319-7242 Volume – 5 Issue -03 March, 2016 Page No. 16058-16063*