



A REVIEW STUDY - SMART GRID INTEGRATION OF RENEWABLE SOURCES USING EZ AND Z SOURCE INVERTERS

Arathi Premnath¹, Aiswarya raj², Dr. V. Shijoh³, Dr. Jarin T⁴

¹UG student, Department of Electrical and Electronics Engineering

Jyothi Engineering College, Thrissur, Kerala, India

²PG student, Department of Power Electronics

Jyothi Engineering College, Thrissur, Kerala, India

³Assistant Professor, Department of EEE

Jyothi Engineering College, Thrissur, Kerala, India

⁴Associate Professor, Department of EEE

Jyothi Engineering College, Thrissur, Kerala, India

Abstract

Smart grid uses digital technology to increase reliability, security and efficiency of the electrical systems.. The use of renewable energy is the most important factor in development of smart grid. The voltage source inverter (VSI) and current source inverter (CSI) are used for interfacing renewable sources to grid. The contents of total harmonic distortion (THD) of VSI and CSI inverter is high, hence it requires filter circuits for mitigation. Z-source inverter (ZSI) overcomes the above mentioned limitations of inverters and it delivers a power conversion theory. Total harmonic distortion created by EZ source inverter is less as compared to Z-Source inverter. The EZ-source inverters are the modest alternatives that can be used for cases where better quality of power is required.

This paper reviews the use of Z- source inverter and EZ source inverter in the integration of renewable energy source in the smart grid.

Keywords: Smart Grid, VSI, CSI, ZSI, EZSI

I. INTRODUCTION

The thought of smart grid lies in the integration of information and communication technologies into the existing power system infrastructure to get maximum benefit to the end-user. The objective of implementing smartness in the grid

is to increase the reliability, efficiency, customer satisfaction and power quality of the vast electrical distribution network. In India the development of smart grid network is necessary to overcome the current power crises. To attain energy security and address environmental concerns, India is emphasizing on harnessing renewable energy resources. Presently installed generation capacity in the country is about 305GW (Jul'16) which constitute capacity from conventional sources viz. coal (186.2GW), Gas (24.5 GW), Nuclear (5.78GW), and Large Hydro (42.85GW). Balance 44.23GW (14.5%) contribution is from renewable generation capacity which has 26.87GW (62.7%) contribution from wind alone. Government of India is having ambitious plan to achieve 175 GW of renewable generation capacity by 2022 which include 100 GW from Solar, 60 GW from wind and balance from small hydro, Biomass etc. To meet growing demand and to reduce supply demand gap, there is a need of large capacity addition through conventional as well as from renewable energy sources. However, to achieve sustainable growth, energy security is of paramount importance. As the Government of India is having an ambitious plan to achieve 1, 00,000MW Solar and 60,000 MW Wind generations in next five years the importance of smart grid integration of renewable resources is also on the rise. Wind and solar energy offer environmental benefits, low operating costs, and

reduced dependence on imported fuel thus ensuring energy sustainability. However, wind and solar generation vary with wind speed, direction of wind and atmospheric temperature and solar insolation. This changeability affects how power systems with high penetrations of renewable energy sources operate. Researchers across the globe are identifying these effects and finding solutions to address them to enable its grid integration.

II. LITERATURE SURVEY

Integration of renewable energy is not possible without the use of power converters especially in solar and fuel cell based generation. The integration is possible using different methods. The Z-source inverter can be used successfully in integration of renewable sources in smart grid[2]. Anjali R. Pawar, & Sanjay A. Deokar has explained the use of EZ source inverter in smart grid in [1]. By the use of EZ source inverter the control of renewable energy source can be made much more easier [3]. A modified version of solar power generation with low total harmonic distortion is also possible using the EZ source inverter [5]. In [6] Ashok Kumar Jhala & Rajeev Gupta R explains design specifications and more application of the Z source inverters.

There are two categories of traditional inverters such as voltage source or current source inverter (VSI/CSI). It consists of DC voltage or current source, three phase inverter bridge. The DC voltage source can be a capacitor, diode rectifier and battery. The DC current source can be a large dc inductor fed by the battery, fuel cell or thyristor converter.

A. VOLTAGE SOURCE INVERTER

A dc voltage source supported by a relatively large capacitor feeds the main converter circuit, a three-phase bridge. The dc voltage source can be a battery, fuel-cell stack, diode rectifier, and/or capacitor. Six switches are used in the main circuit; each is traditionally composed of a power transistor and an antiparallel (or freewheeling) diode to provide bidirectional current flow and unidirectional voltage blocking capability. The V-source converter is widely used, as shown in fig 1 [2].

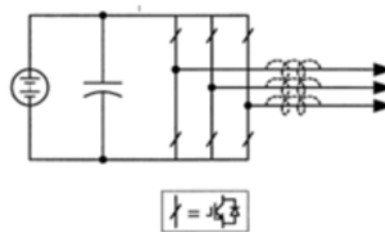

Fig 1 Voltage Source Inverter

ADVANTAGES

- Output Voltage waveform is independent of load.
- The inverter configuration is Compact.
- No need of Diodes

DISADVANTAGES

- The ac output voltage is limited below and cannot exceed the dc-rail voltage or the
- Dc-rail voltage has to be greater than the ac input voltage. Therefore, the V-source
- inverter is a buck (step-down) inverter for dc-to-ac power conversion and the V-source
- Converter is a boost (step-up) rectifier (or boost converter) for ac-to-dc power conversion.
- For applications where over drive is desirable and the available dc voltage is limited, an
- Additional dc-dc boost converter is needed to obtain a desired ac output. The additional
- Power converter stage increases system cost and lowers efficiency.
- The upper and lower devices of each phase leg cannot be gated on simultaneously either by purpose or by EMI noise.

B. CURRENT SOURCE INVERTER

Main converter circuit, three-phase Bridge are fed by the dc current source. The dc current source can be a relatively large dc inductor fed by a voltage source. Six switches are used in the main circuit, each is traditionally composed of a semiconductor switching device with reverse block capability such as a gate-turn-off thyristor (GTO) and SCR or a power transistor with a series diode to provide unidirectional current flow and bidirectional voltage blocking as shown in fig 2 [2].

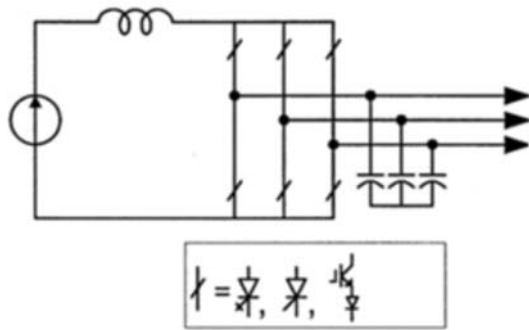

Fig 2 Current Source Inverter

ADVANTAGES

- Instantaneous conduction in an inverter arm is controlled by the 'controlled current source' used here, that is a current limited voltage source in series with a large value inductance.
- The converter-inverter of combined configuration has inherent four-quadrant operation capability without any extra power component

DISADVANTAGES

- At least one of the upper devices and lower devices have to be gated on and maintained on at any time. Or else, an open circuit of the dc inductor would occur and destroy the devices.
- The main switches of the I-source converter have to block reverse voltage that requires a series diode to be used in arrangement with high-speed and high-performance transistors such as insulated gate bipolar transistors (IGBTs). This prevents the direct use of low-cost and high-performance IGBT.
- A minimum load at the output is required, and the commutation capability is dependent upon load current. This limits the operating frequency, and also puts a limitation on its use for UPS systems.
- These inverters have sluggish performance and stability problems at light loads, and high frequency

III. SMART GRID

Smart grid is defined as the electricity network that intelligently integrates generators and consumers to efficiently deliver electricity which is sufficient capacity and coverage area accessible, safe, economic, reliable, efficient, and sustainable. The growing installations of renewable energy resources require a coordinated effort from the planning stage all the

way down to the electronic devices used for power generation, distribution, storage and consumption. The electricity grid to accommodate higher percentage of renewable energy would need large quantities of conventional back up power and huge energy storage. These would be necessary to compensate for natural variations in the amount of power generated depending on the time of day, season and other factors such as the amount of sunlight or wind at any given time. Since today's electricity grid cannot handle this variability, the cost of adopting the renewable energy sources is much more expensive than it should be.

A. NEED FOR SMART GRIDS IN INDIA

According to the Ministry of Power, India's transmission and distribution losses are amongst the highest in the world, averaging 26 per cent of total electricity production, and as high as 62 per cent in some states. These losses do not include non-technical losses like theft etc.; if such losses are included, the average losses are as high as 50 per cent. India has least electric grids in the world. A poorly planned distribution network, there is overloading of the system components, there is low metering efficiency and bill collection, there is lack of reactive power support and regulation services etc are the technical flaws in the Indian power grid. India is venturing very fast into renewable energy (RE) resources like wind and solar. Solar has a great potential in our country, India with its average of 300 solar days per year. The government is also providing incentives for solar power generation in the form of subsidies for various solar applications; and has set a goal that solar should contribute 7 per cent of India's total power production by 2022. With such high targets, solar is going to play a key role in shaping the future of India's power sector. A lacuna of renewable resources is that their supply can be intermittent i.e. the supply can only be harnessed during a particular part of the day, like day time for solar energy and windy conditions for harnessing wind energy, also these conditions cannot be controlled. Therefore the opportunities for building smart grids in India are immense, as a good electric supply is one of the key infrastructure requirements to support overall development.

IV Z SOURCE INVERTER

It employs a unique impedance network to couple with the converter main circuit to the dc power source as shown in Fig 3. Inductors L1 and L2 and capacitors C1 and C2 connected in X shape to provide an impedance source coupled to the dc source [1]. The dc source can be either voltage or current source. When the two inductors (L1 and L2) are reduced to be zero, then the Z-source network consists of two capacitors (C1 and C2) are in parallel and it becomes (represents) traditional voltage source. When the two capacitors (C1 and C2) are reduced to be zero, then the Z-source network presents the two inductors (L1 and L2) are in series and it becomes (represents) the traditional current source. Therefore the inductor and capacitor requirements should be smaller than the traditional inverters.

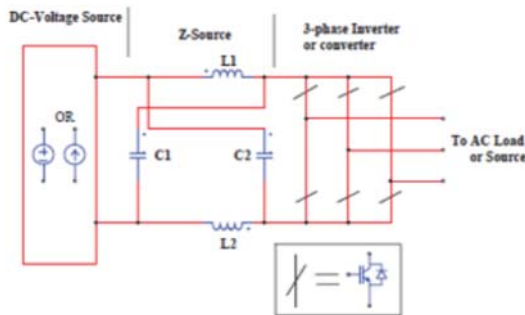

Fig 3 Z Source Inverter

Also Z-source inverter is also called as a buck-boost inverter. The Z source concept can be applied to all types of power conversions like dc-to-ac, ac-to-dc, ac-to-ac, and dc-to-dc. A boost dc-dc converter is needed for distributed power generation, because the V source inverter cannot produce an ac voltage that is greater than the dc voltage. Z-source inverter for such applications, which can directly produce an ac voltage greater and less than the input voltage. The diode in series is usually needed for preventing reverse current flow. The Z-source inverter is a buck-boost inverter that has a wide range of obtainable voltage.

V EMBEDDED Z SOURCE INVERTER [EZSI]

The modified Z Source Inverter is known as Embedded Z Source Inverter [EZSI] as shown in fig 4. EZ-source inverter means embedding the dc input sources within the LC impedance system. Its inductive element is used for current filtering in voltage type of E Z source inverter

and its capacitive element is used for voltage filtering in current type of E Z source inverter [1].

It needed two DC sources of $V_{dc}/2$, instead of the single DC source shown in Figure.

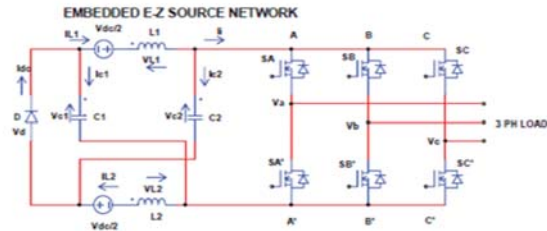

Fig 4 EZSI

Although this requirement can have the higher cost, but it is not a major problem for PV or fuel cell application. Therefore it is not viewed as a series limitation and can be overcome by the advantages shown by the EZ-source inverter including its inherent filtering ability. These advantages are demonstrated by investigating the inverter principle, which involves shoot-through and nonshoot-through states. Switches from the same phase leg can be switched on simultaneously. Here diode is used for providing bidirectional current flow and unidirectional voltage blocking capability

A. SHOOT THROUGH STATE

In the shoot through state of EZ-source inverter, two switches from the same leg is turned on, and this type of operation is not possible in the conventional inverter, therefore switch S is turned on. The three-phase EZ-source inverter bridge has 9 permissible switching states (vectors) unlike the traditional three-phase V-source inverter that has eight. The traditional three-phase V-source inverter has 6 active vectors.

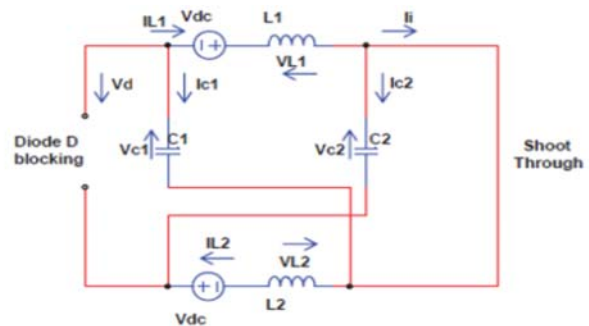

Fig 5 Shoot through state

The three-phase Z-source inverter bridge has 1 extra zero state (or vector) when the load terminals are shorted through the upper and

lower devices of any one phase leg (both devices are gated on), any two phase legs, or all three phase legs. This shoot-through zero state (or vector) is forbidden in the traditional V-source inverter, because it would cause a shoot-through. We label this third zero state (vector) the shoot-through zero state (or vector), which can be generated by seven different ways: shoot-through via any one phase leg, combinations of two phase legs, or all three phase legs. The shoot-through zero state possible by Z-source network. This shoot-through zero state provides the unique buck-boost feature to the inverter. The circuit for this mode of operation is shown in fig 5. When the inverter bridge is in shoot-through state, the diode D is reverse biased with its blocking voltage state and the shoot-through state equations is derived as follows[4].

B. NON SHOOT THROUGH STATE

In non-shoot through state the switch S is open in this state, and the input diode is forward biased, allowing active or null states of the EZSI. Also, in this state the external power source charges the z-source capacitors, though the inductors. Thus in non-shoot through mode it conducts in any one of the six active states. Note that the inverter bridge can be also represented by a current source with zero value (i.e., an open circuit) when it is in one of the two traditional zero states. The figure 6 shows an equivalent circuit of the E Z-source inverter which is viewed from the dc link when the inverter bridge is in one of the eight non shoot-through switching states[4].

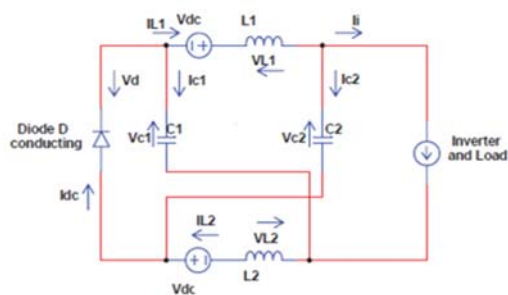

Fig 6 Non Shoot Through State

VI CONCLUSION AND FUTURE SCOPE

The embedded EZ-source inverters have the advantages of drawing a smoother current from the dc input sources without using external second-order filters, and a lower required capacitive voltage as comparing with the Z-

source inverters,. These advantages can be attained with no degradation in gain, diode blocking voltage and other characteristic properties of the X-shaped impedance network for the same specified shoot-through duration. Problems like integration of renewable energy in smart grid can be solved using EZ-source inverter. In this strategy issues related to power quality can be handled effectively. During the analysis and simulation, it is observed that the total harmonic distortion is reduced to 2.65, which is within the IEEE limit. Moreover confirms that the THD of E Z-source inverter system is very less than its counterpart and it is very much promising power conversion concept for photo voltaic system in order to increase the overall system efficiency, thereby reducing system complexity and cost.

REFERENCES

- [1] Anjali R. Pawar, & Sanjay A. Deokar, "Design of Embedded EZ-Source Inverter for the Integration of renewable Energy Sources in Smart grid," International Conference on Industrial Instrumentation and Control (ICIC), College of Engineering Pune, India., pp 49-54, May 2015
- [2] Fang Zheng Peng Tan, "Z-Source Inverter" IEEE Transactions on Industry Applications, pp.504-510 Vol. 39, no. 2, March/April 2003.
- [3] S.Kamalakkannan, & S.Deva Gowda, "Digital Simulation Of Renewable Energy Source Controlled EZ-Source Inverter System," International Conference on Computing, Electronics and Electrical Technologies [ICCEET], pp. 424-428, Vol. 2, Issue 4, June-July 2012.
- [4] Poh Chiang Loh, Feng Gao, & Frede Blaabjerg "Embedded EZ-Source Inverters" IEEE Transactions on Industry Applications, pp. 256-267, Vol 46, Jan/Feb 2010.
- [5] Selva santhosh Kumar, & Priyaa Dharshini R S "Modified Solar Power Generation Using Impedance Source Inverter" IEEE International Conference on Advanced Communication Control and Computing Technologies (ICACCCT), pp. 185-191, 2014.
- [6] Ashok Kumar Jhala & Rajeev Gupta R S "Z-Source Inverters: Design and Applications" International Journal of Electronics and Communication Engineering & Technology (IJECET), pp. 17-24, vol 6, Dec 2015