



SIMULATION OF 36 PULSE 3 PHASE AC TO DC CONVERTERS

A.Srikanth¹, T. V. Sai Kalyani², S Trilochana³, Dr. M. Surya Kalavathi⁴

^{1,2,3}Asst.Professor, EEE Dept, St.Martin's Engineering College

⁴Professor, EEE Dept, JNTUH, Kukatpally, Telangana

Abstract

This paper presents simulation of 36 PULSE 3 PHASE AC TO DC CONVERTERS. The three-phase 36 pulse AC to DC conversion system employs a phase-shifting transformer and a three-phase. Every such converter provides 6-pulse AC to DC conversion, so in order to produce more sets of 6-pulse systems, a uniform phase-shift is required and hence with proper phase-shifting angle, 12, 18, 24, 30, and higher pulse systems have been produced. The main focus of this study is to simulate 36 pulse AC-DC conversions. The performance improvement of multi-pulse converter is achieved for total harmonics distortion (THD) in supply current, DC voltage ripples and form factor. The 36 pulse AC-DC converters configurations using MATLAB/SIMULINK. Index Terms: 6-pulse, 12-pulse, 18-pulse, 36-pulse AC-DC, Power Quality.

I. INTRODUCTION

The three-phase 36 pulse AC to DC conversion system employs a phase-shifting transformer and a three-phase converter between the supply and load side of the system. Every such converter provides 6-pulse AC to DC conversion, so in order to produce more sets of 6-pulse systems, a uniform phase-shift is required and hence with proper phase-shifting angle, 12, 18, 24, 30, and higher pulse systems can be produced. Different rectifiers are used for conversion of AC supply into DC supply. For uncontrolled conversion, diodes have been preferred, while for the controlled conversion, thyristors have been implemented. In this paper the simulations done

for 6-pulse, 12-pulse, 24-pulse and 36-pulse. All the simulations have been done for similar ratings of R Load, for all converters configurations, so as to represent a fair comparison among controlled and uncontrolled continuations of multi-pulse converters. In this paper the simulation was done for 6-pulse, 12-pulse, 24-pulse and 36-pulse AC to DC converter.

II. SIMULATION FOR 6-PULSE CONVERTER

The simulation of six-pulse converter is shown in Fig.1, where A, B and C are the phase voltages of the 3 phase supply. For medium-voltage applications, each diode in the rectifier may be replaced by two or more diodes in series. To simplify the analysis, all the diodes are assumed to be ideal (no power losses or on-state voltage drop). The simulation results are shown in Fig.1.a. simulation results for 6-pulse converter input 3phase voltage and output voltage and Fig.1.b. simulation results for 6-pulse converter input current and output current. The input current was disturbing when converting 6-pulse AC to DC.

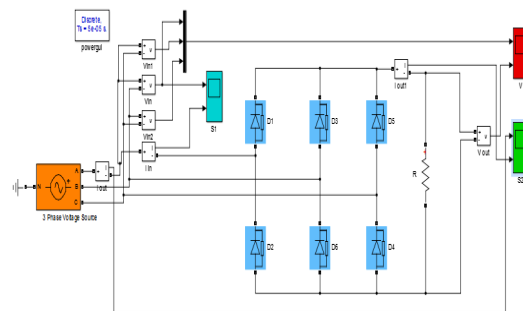

Fig.1. simulation of 6-pulse converter

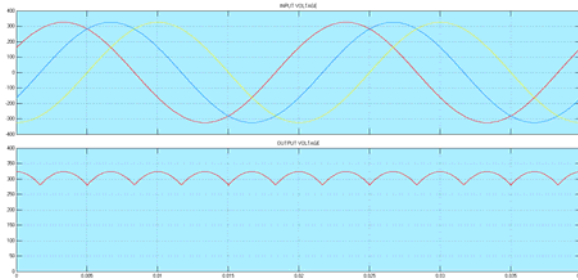

Fig.1.a. simulation results for 6-pulse converter input 3phase voltage and output voltage

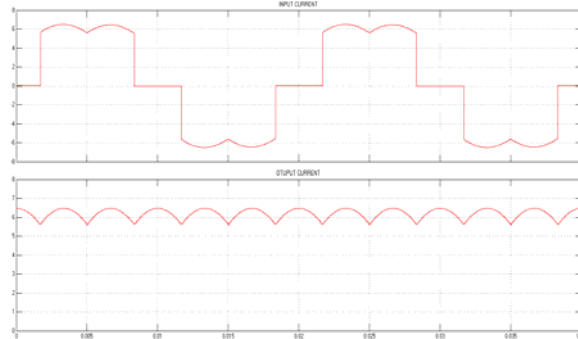

Fig.1.b. simulation results for 6-pulse converter input current and output current

III. SIMULATION FOR 12-PULSE CONVERTER

The simulation of 12-pulse converter is shown in Fig.2, where A, B and C are the phase voltages of the 3 phase supply. Two Zigzag Phase-Shifting Transformer block implements a three-phase transformer with a primary winding connected in a zigzag configuration and a configurable secondary winding.

The model uses three single-phase, three-winding transformers. The primary winding connects the windings 1 and 2 of the single-phase transformers in a zigzag configuration. Two Universal Bridge block implements a universal three-phase power converter that consists of up to six power switches connected in a bridge configuration.

The type of power switch and converter configuration are selectable from the dialog box. The Universal Bridge block allows simulation of converters using both naturally commutated (or line-commutated) power electronic devices (diodes or thyristors) and forced-commutated devices (GTO, IGBT, MOSFET). The Universal Bridge block is the basic block for building two-level voltage-sourced converters (VSC).

The simulation results are shown in Fig.2.a. simulation results for 12-pulse converter input 3phase voltage and output voltage and Fig.2.b. simulation results for 12-pulse converter input

current and output current. The input current was some changes when converting 12-pulse AC to DC. Comparing to 6-pulse converter 12-pulse was better.

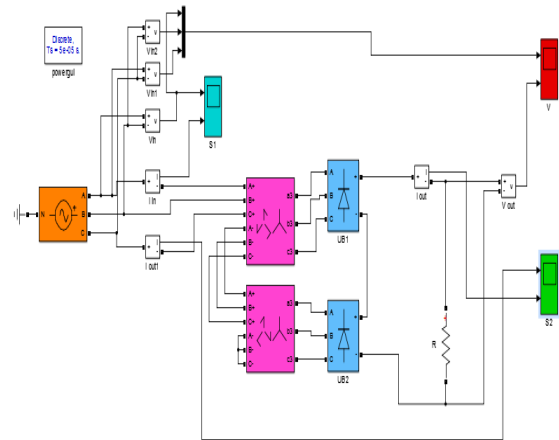

Fig.2. simulation of 12-pulse converter

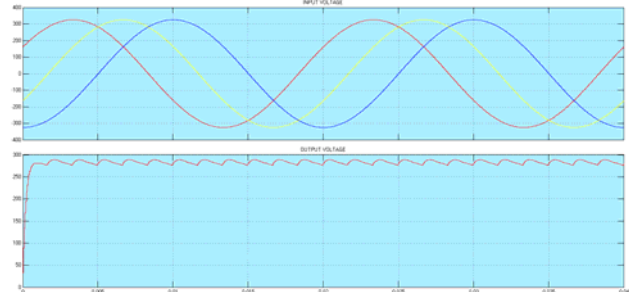

Fig.2.a. simulation results for 12-pulse converter input 3phase voltage and output voltage

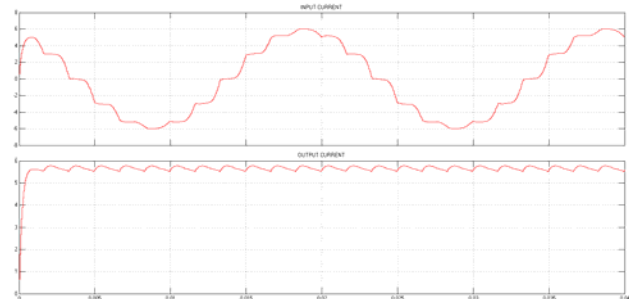

Fig.2.b. simulation results for 12-pulse converter input current and output current

IV. SIMULATION FOR 24-PULSE CONVERTER

The simulation of 24-pulse converter is shown in Fig.3, where A, B and C are the phase voltages of the 3 phase supply. Four Zigzag Phase-Shifting Transformer block implements a three-phase transformer with a primary winding connected in a zigzag configuration and a configurable secondary winding.

The model uses three single-phase, three-winding transformers. The primary winding

connects the windings 1 and 2 of the single-phase transformers in a zigzag configuration. Four Universal Bridge block implements a universal three-phase power converter that consists of up to six power switches connected in a bridge configuration. The type of power switch and converter configuration are selectable from the dialog box. The Universal Bridge block allows simulation of converters using both naturally commutated (or line-commutated) power electronic devices (diodes or thyristors) and forced-commutated devices (GTO, IGBT, MOSFET). The Universal Bridge block is the basic block for building two-level voltage-sourced converters (VSC).

The simulation results are shown in Fig.3.a. simulation results for 24-pulse converter input 3phase voltage and output voltage and Fig.3.b. simulation results for 24-pulse converter input current and output current. The input current was small changes when converting 24-pulse AC to DC. Comparing to 6-pulse and 12-pulse converter 24-pulse converter was better.

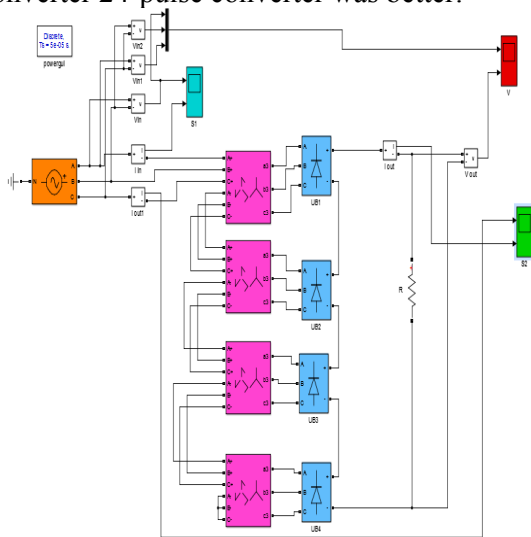

Fig.3. simulation of 24-pulse converter

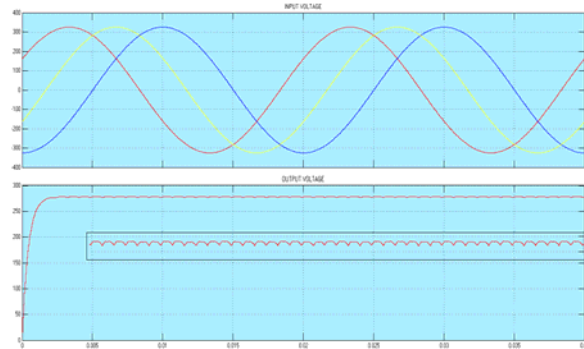

Fig.3.a. simulation results for 24-pulse converter input 3phase voltage and output voltage

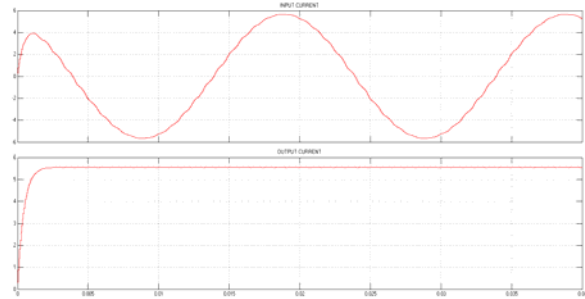

Fig.3.b. simulation results for 24-pulse converter input current and output current.

V. SIMULATION FOR 36-PULSE CONVERTER

The simulation of 36-pulse converter is shown in Fig.4, where A, B and C are the phase voltages of the 3 phase supply. Six Zigzag Phase-Shifting Transformer block implements a three-phase transformer with a primary winding connected in a zigzag configuration and a configurable secondary winding.

The model uses three single-phase, three-winding transformers. The primary winding connects the windings 1 and 2 of the single-phase transformers in a zigzag configuration. Six Universal Bridge block implements a universal three-phase power converter that consists of up to six power switches connected in a bridge configuration.

The type of power switch and converter configuration are selectable from the dialog box. The Universal Bridge block allows simulation of converters using both naturally commutated (or line-commutated) power electronic devices (diodes or thyristors) and forced-commutated devices (GTO, IGBT, MOSFET). The Universal Bridge block is the basic block for building two-level voltage-sourced converters (VSC).

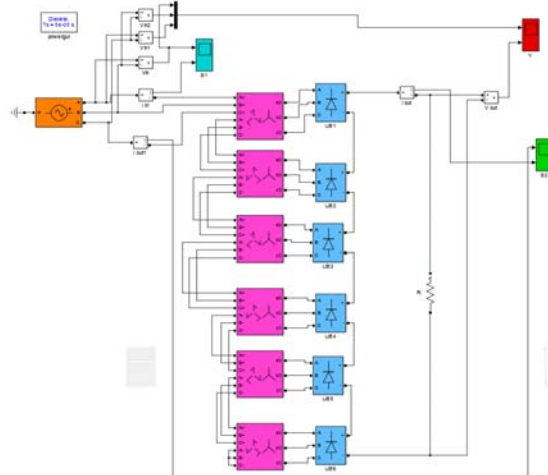

Fig.4. simulation of 36-pulse converter

A. Simulation analysis for 36-pulse AC-DC Converter

3-phase programmable voltage source
Amplitude=230 Vrms Ph-Ph
Phase=0deg.
Frequency=50Hz
Universal bridge arms=3

Zigzag phase shifting transformer

This block implements a three-phase phase-shifting transformer by using three single-phase three-winding transformers. Primary consists of windings 1 and 2 connected in zig-zag. All primary terminals are accessible. Secondary (winding 3) can be connected in wye or delta.

Nominal power=10e3vA

Frequency=50Hz

Primary (zig-zag) nominal voltage=230 Vrms Ph-Ph

Secondary nominal voltage=230 Vrms Ph-Ph

Zigzag phase shifting transformer1 phase shift=-5

Zigzag phase shifting transformer2 phase shift=+5

Zigzag phase shifting transformer3 phase shift=-15

Zigzag phase shifting transformer4 phase shift=+15

Zigzag phase shifting transformer5 phase shift=-25

Zigzag phase shifting transformer6 phase shift=+25

B. Simulation results for 36-pulse AC-DC Converter

The simulation results are shown in Fig.4.a. simulation results for 36-pulse converter input voltage and INPUT CURRENT, Fig.4.B. simulation results for 36-pulse converter input 3phase voltage and output voltage and Fig.4.C. simulation results for 36-pulse converter input current and output current. Fig.4.d. simulation results for 36-pulse converter output voltage and output CURRENT

The input current was less changes when converting 36-pulse AC to DC comparing to other converters.

VI. CONCLUSION

The simulations done for 6-pulse, 12-pulse, 24-pulse and 36 -pulse 3 Phase AC to DC

converter. All the simulations have been done for similar ratings of R Load, for all converters configurations, so as to represent a fair comparison among controlled and uncontrolled continuations of multi-pulse converters. The comparison of input current and output voltage was done for all converters.

REFERENCES

- [1] Singh B., Gairola S., Singh B.N. et al., Multipulse AC-DC converters for improving power quality: a review. IEEE Trans. on Power Electronics 23(1): 260-281(2008).
- [2] Institute of Electrical and Electronic Engineers (IEEE), IEEE Standard 519-1992, IEEE Guide for Harmonic Control and Reactive Compensation of Static Power Converters. IEEE Inc. (1992).
- [3] B.Singh, S.Gairola, B.N.Singh, A.Chandra, and K.A.Haddad, —Multi-pulse AC-DC Converter for Improving Power Quality: A Review| IEEE Transactions, On Power Delivery, Vol.23 No.1 January 2008.
- [4] IEC Standard 61000-3-2:2004, Limits for Harmonic Current Emissions, Int. Electromechanical Commission, Geneva, 2004.
- [5] D.A. Paice, Power Electronic Converter Harmonics: Multi-pulse Methods for Clean Power, IEEE Press, New York, 1996.
- [6] L.J. Johnson and R.E. Hammond, “Main and auxiliary transformer rectifier system for minimizing line harmonics”, U.S. Patent 5 063 487, Nov. 1991.
- [7] V. Nedic and T. A. Lipo, “Low-cost current-fed PMSM drive system with sinusoidal input currents,” IEEE Trans. Ind. Appl., vol. 42, no. 3, pp. 753– 762, May/Jun. 2006.
- [8] W. Farrer, “Significant source harmonic reduction achieved using direct parallel connection of two 6-pulse converters,” Proc. Inst. Electr. Eng.—Electr. Power Appl., vol. 153, no. 2, pp. 167–176, Mar. 2006.
- [9] K. Mukherjee, S. SenGupta, T. K. Bhattacharya, A. K. Chattopadhyay, and S. N. Bhadra, “Simplified analytical averaged model of a thyristorized commutatorless series motor,” IEEE Trans. Ind. Appl., vol. 42, no. 6, pp. 1508–1515, Nov./Dec. 2006.
- [10] Data From MATLAB.