



HEAT PUMP BASED ENERGY EFFICIENT HEATING AND COOLING SOLUTIONS FOR AUTOMOTIVE INDUSTRY

K. Ravi Kumar¹, D S Kumar², G Pramod Kumar³

^{1,2,3}MVGR College of Engineering (A), Vizianagaram, Andhrapradesh, India

ABSTRACT

In many automotive industries for various washing machines, temperature of water used to clean the parts is a very important requirement. The method to heat the water for this washing process was previously accomplished by using various water heating methods such as by Electrical Resistance Heating method, HSD/LPG Fired Boiler, NG Fired Boiler. This method can now be replaced by an Energy Efficient Heating technique using Heat Pump. Heat Pump is one such device which gives an output three times than that of the input energy. An outlet water temperature of about 65°C can be obtained from this method. Now this technique can be used to heat the water required for the washing process by inculcating a few modifications in the system. The modifications include replacing the present water heating system by Heat Pump water heating system. This can be achieved by proper base lining and detailed analysis of the present system.

In the present work the electrical resistance water heating technique is being replaced by a heat pump system, which is done by gathering the electrical consumption data of the electric heaters. This electric consumption plays a vital role in sizing the heat pump. Once the heat pump sizing is completed this can be further used to obtain the size of hot water circulation pump by taking a fixed temperature difference into consideration. Few modifications has to be done in the tank containing hot water i.e. a helical coil heat exchanger will be designed based on the running load of the tank. Before designing the helical coil the various losses in

the tank has to be found and based on this load heat exchanger designing process will begin. In this system the Heat Pump will be used to heat the water in two tanks but the design of the Heat Exchanger has been done only for one tank. Based on the various losses from the tank the total running load required to maintain the water temperature of the machine1&2 at 65°C was 30kW. Heat Exchanger design was modeled by considering the previous result of the running load of the hot water storage tank.

1. LITERATURE REVIEW

S.N.Nalawade, G.B.Jadhav and N.N.Shinde[1], Analyzed that Heat pump application delivers an efficient way to replace the electrical energy for heating application in an industry, specifically for large-scale installations. They found that this technology is very cost effective, Eco friendly source for water heating application which significantly reduces the use of electrical energy consumption. An analysis of heat pump system for water heating application at the process industry established a new option for water heater. This paper presents key issues that will define how well, and to what extent, this technology will fit into process industry. The paper also shows the results of a life-cycle cost analysis of heat pump water heating system. The commercial analysis was carried out for 7500 liter hot water per day. The results show that system COP can reach up to 3.12A extremely substantial factor of cost saving is about 66.67 % with heat pump system. Electricity consumption of 480 units as per day is saved by using heat pump water heating system. Ioan Sarbu, Calin Sebarchievici [2].General review of ground-source heat pump systems for heating and

cooling of buildings” this paper explains that A large number of ground-source heat pumps (GSHP) systems have been used in residential and commercial buildings throughout the world due to the attractive advantages of high energy and environmental performances. The GSHPs are proven renewable energy technology for space heating and cooling. This paper provides a detailed literature review of the GSHP systems, and their recent advances. The operation principle and energy efficiency of a heat pump are defined first. Then, a general introduction on the GSHPs and its development, and a detailed description of the surface water (SWHP), ground-water (GWHP), and ground-couplet (GCHP) heat pumps are performed. The most typical simulation and ground thermal response test models for the vertical ground heat exchangers currently available are summarized including the heat transfer processes outside and inside the boreholes. Also, some information about a new GWHP using a heat exchanger with special construction, and the possibility to obtain the better energy efficiency with combined heating and cooling by GCHP are presented. The various hybrid GCHP systems for cooling or heating-dominated buildings are well described. Finally, the energy, economic and environmental performance of a closed-loop GCHP system is also briefly reviewed. It is found that the GSHP technology can be used both in cold and hot weather areas and the energy saving potential is significant. Arif Hepbasli, Mr. Yildiz Kalinci [3]A review of heat pump water heating systems” this paper shows that A heat pump water heater (HPWH) operates on an electrically driven vapor-compression cycle and pumps energy from the air in its surroundings to water in a storage tank, thus raising the temperature of the water. HPWHs are a promising technology in both residential and commercial applications due to both improved efficiency and air conditioning benefits. Residential HPWH units have been available for more than 20 years, but have experienced limited success in the marketplace. Commercial-scale HPWHs are also a very promising technology, while their present market share is extremely low. This study dealt with reviewing HPWH systems in terms of energetic and exergetic aspects. In this context, HPWH technology along with its historical development was briefly given first. Next, a comprehensive review of studies conducted on them were classified and presented in tables.

HPWHs were then modeled for performance evaluation purposes by using energy and exergy analysis methods. Finally, the results obtained were discussed. It is expected that this comprehensive review will be very beneficial to everyone involved or interested in the energetic and exergetic design, simulation, analysis, performance assessment and applications of various types of HPWH systems. Guozhong Zheng et.al [4] Thermodynamics Performance Study on Air Source Heat Pump in Variant Operating Condition” A certain product of the air source heat pump is selected as the study object in the paper. By variant condition operating performance of such air source heat pump in variant condition of the air source heat pump offered by manufacturer, the thermodynamics analyses are made based on the first law of thermodynamics and exergy analyze theory. Coefficient of Performance (COP) and exergy efficiency in variant operating condition are calculated, and then the curves for the relationship of COP and exergy efficiency with the outlet temperature of the chilling water/heating water and the Environment temperature are plotted. The COP functions concerning with the outlet temperature of the chilling water/ heating water and the environment temperature are fitted. Conclusions on variant condition and operation of the air source heat pump are drawn by comparing these two theories. Finally, it indicates that the best operating condition should be set considering COP, exergy analysis and practical requirement for cold and thermal.

Rajnikant S. Jadhao, tejay V. Lanjewar [5] AN INDUSTRIAL HEAT PUMP FOR STEAM AND FUEL SAVINGS” Currently many consumers in the India are facing with increasing shortages of electricity and petroleum gas. Prices have yet to stabilize and continue to increase as the shortages continue. What can then consumers do when facing with high heating bills and the need to stay warm and comfortable? The answer to this may come from alternate heating systems. One such alternative to current heating systems is called a heat pump. A heat pump is defined as an electrically driven device used to transfer heat energy from one location to another. A heat pump can be used as a heating unit, an air-conditioning unit or a water heater. Industrial heat pumps are a class of active heat-recovery equipment that allows the temperature of a

waste-heat stream to be increased to a higher, more useful temperature. Consequently, heat pumps can facilitate energy savings, when conventional passive-heat recovery is not possible. The focus is on the most common applications, with guidelines for initial identification and evaluation of the opportunities being provided. Heat pump is a device that can increase the temperature of a waste-heat source to a temperature, where the waste heat becomes useful. The waste heat can then replace purchased energy and reduce energy costs. However, the increase in temperature is not achieved without cost. A heat pump requires an external mechanical- or thermal energy source. The goal is to design a system in which the benefits of using the heat-pumped waste heat exceed the cost of driving the heat pump. Heat can be extracted from various sources such as cooling tower water or various heating sources. B.J. Huang, C.P. Lee [6] Long-term performance of solar-assisted heat pump water heater” A long-term reliability test of an integral-type solar-assisted heat pump water heater (ISAHP) was carried out. The prototype has been running continuously for more than 13,000 h with total running time >20,000 h during the past 5 yr. The measured energy consumption is 0.019 kWh/l of hot water at 57°C that is much less than the backup electric energy consumption of the conventional solar water heater.

2. METHODOLOGY

A heat pump is a device that is able to transfer heat from one fluid at a lower temperature to another at a higher temperature for process

heating. Heat pumps work on vapor compression system with the refrigerant R134a. The shell and tube type cooled heat exchanger is used as a condenser. The heat rejected by the condenser into the water in present in the condenser is consisting of heat absorbed by the evaporator side from atmospheric air and heat added during compression.

Generally washing machines contains electrical heaters which are used to heat up the solution present in the tank. This hot solution is used to wash the components for various requirements. For example 30kW rated electrical heater producing 30kWe thermal energy like that for same 30kWe thermal energy requirements we can suggest the heat pump which consumes the less input electrical energy and its depends on the cop of the heat pump so that we can save the energy.

Proper installation and maintenance of heat pump water heating system can optimize its energy efficiency. First of all visit the site and find out the machines which consumes more input energy

And then collect the data from machine i.e. number of tanks, each tank capacity, number of electrical heaters connected to machines, each electrical heater load, operating hours, operating days, energy cost, operating temperature. According to data estimate energy consumes for each year and designs the heat pump and calculate the estimated energy savings. Calculate the estimated payback period of heat pump. Design the circulation pump and heating coil without changing its operating temperature of the machine.

2.1 Heat Pump energy efficiency process:

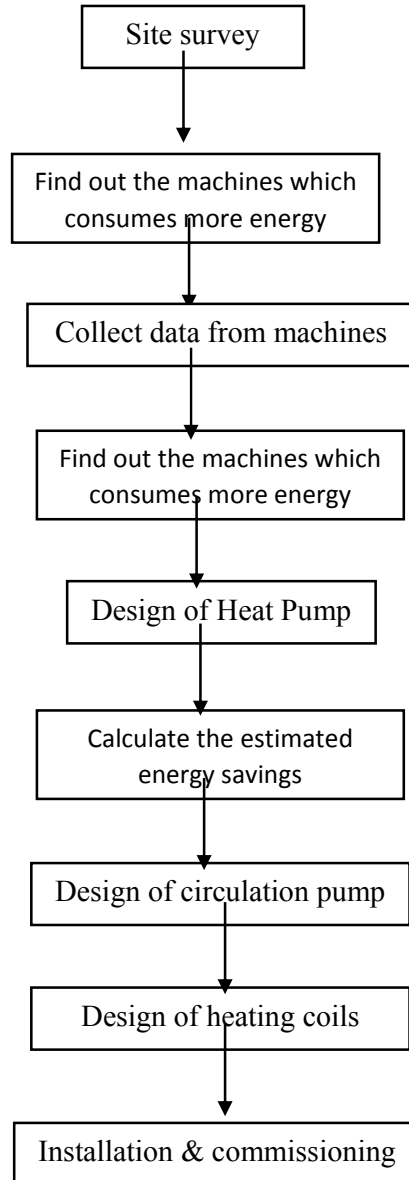

3.2 Data collected from the site:

Table 3.1 Machine1&2 details

Parameters	Units	Machine-1	Machine-2
Flood tank capacity	ltrs	600	600
No.of heaters	-	6	9
Each heater reading	kW	3	3
Total rated capacity	kW	18	27

Power consumption of heaters	kW	15.5	23.2
Operating hours	hrs	16	16
Energy consumption/day	kWH	248	371
Diversity factor	%	55	55
Energy consumption /day with diversity factor	kWH	136	204
Average heating requirements in the tanks	kW	8.53	12.75
Annual operating days	Days	300	300
Annual energy consumption	kWH	40920	61248
Energy cost	Rs/kWH	8.93	8.93
Annual energy cost	Millions	0.37	0.55
Total energy cost	Millions	0.91	

3.3 Sizing of Heat Pump:

Table 3.2 design of heat pump and energy savings

Parameters	Units	Machine-1	Machine-2
COP	-	2.5	2.5
Heat Pump capacity	kW	30	
Heat Pump energy consumption	kW	3.4	5.12
Annual Heat Pump energy consumption	kWH	40867	

Annual Heat Pump energy cost	Millions	0.365
Annual energy savings	%	54.7
Annual energy savings with 90% diversity factor	%	49.3

As per the calculations estimated energy savings is 49.3% and connected Heat pump capacity is 30kW to maintain the same operating temperature for machine1 &2. Total energy cost for existing system is 0.91 million/annum by proposing the 30kW Heat pump connection to the existing system (electrical based heating) is decreasing up to 0.365 million/annum.

3.4 Objective of the proposed solution:

- By the observation of machines, initially machine contains electrical heaters for

3.5 PROPOSED SOLUTION SCHEMATIC:

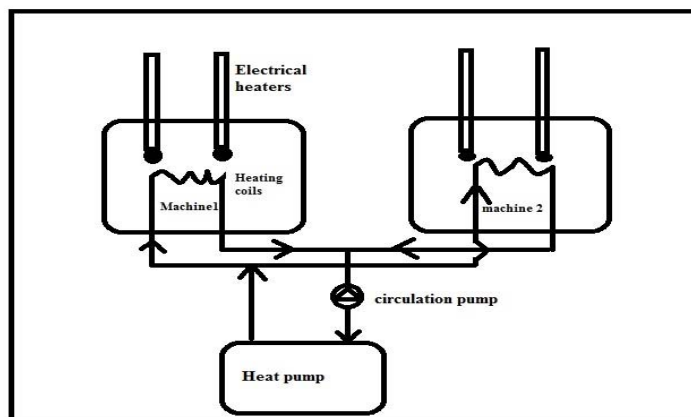

Fig 3.1 shows that Heat pump connected to the machines

3.6 Proposed system description:

- For electrical heaters more energy consumption since coefficient of performance is 1.This means every kWh electricity supplied to the electrical heater 1kWh of useful heat is transferred.
- For Heat Pump less energy consumption since overall coefficient of performance is 2.5.This means every kWh electricity supplied to the Heat Pump 2.5kWh of useful heat is transferred.

heating the solution in the chemical bath for washing the components.

- The main objective of the energy efficiency solution is to eliminate the electrical resistance based heating.
- The recommended solution is to install the heat pump to the chemical bath tanks and maintain the same operating temperature

3.7 Accessories required for proposed system:

- 30kW air source Heat Pump
- Hot water circulation pump
- Heating coils
- Piping & isolated valves
- Electrical panel

Analysis of heat pump system for water heating application for washing application is based on the theoretical and practical basis; here Savings in money related with annual electricity reductions are good and beneficial. Below table

shows the total Economic analysis of heat pump. The 30 kW electric heater run for the water consumption of 2000 liters per day and the electricity consumption is 102168 kWhr/year. Using heat pump in process line gives maximum output i.e. 30 kW with taken of 1/2.5 electrical input as compared to that of electrical heaters. For heat pump, energy consumption is 40867 kWhr/year which gives saving around 61301

kWhr/year. Considering the economic annual life cycle costs of heat pump were Rs. 3.65 Lakh/annum & electric heater is around Rs. 9.1 Lakh/annum.so here saving of around Rs.5.45 Lakh/annum is achieved. An additional annual cost by considering maintenance of heat pump. The majority of savings in money as well as energy is associated with the electricity consumption.

3.7 Estimated payback period calculations:

Table 3.3 Estimated payback period details

DETAILS	VALUE
30 kW Heat Pump cost	12 lacs
Installation cost for 1 Heat Pump	1lac
Total cost	13 lacs
1 st year depreciation	2.4
2 nd year depreciation	0.48
3 rd year depreciation	0.096
Energy cost savings (1 st year)	0.49
Energy cost savings (5% YOY increase)	0.52
Energy cost savings (5% YOY increase)	0.54
Net inflow (depreciation + energy cost savings)	4.526
Simple payback without depreciation	2.37yrs
Simple payback without depreciation	2.11yrs

The flow through a curved pipe has been attracting much attention because heating coiled

pipes are widely used in practice as heat exchangers and chemical reactors. The fluid

flowing through curved tubes induces secondary flow in the tubes. This secondary flow in the tube has significant ability to enhance the heat transfer due to mixing of fluid. The intensity of secondary flow developed in the tube is the function of tube diameter (d) and coil diameter (D). Due to enhanced heat transfer in heating coiled configuration the study of flow and heat transfer characteristics in the curved tube is of prime important.

In most Industries, the designing and thermal evaluation of heat exchangers is generally carried out in order to reduce cost, material and energy and to obtain maximum heat transfer. The main challenge in heat exchanger design is to make it compact and to get maximum heat transfer in minimum space. The passive enhancement technique using coiled tube has significant ability in enhancing heat transfer by developing secondary flow in the coil. Due to enhanced heat transfer the study of flow and heat transfer in helical coil tube is of vital importance. A first approximation of the steady motion of incompressible fluid flowing through a coiled pipe with a circular cross-section is considered in his analysis.

3.8 Design of heating coils:

Data collected from the site survey
 Operating temperature of the tank = 65°C or 338.15K
 Fluid inlet temperature in heating coil= 75°C or 348.15K
 Fluid outlet temperature in heating coil= 70°C or 343.15K
 Length of the tank = 1.5m
 Width of the tank = 0.7m
 Depth of the tank = 0.6m
 Designed pump flow rate = 5m³/hr
 Designed pump flow rate in each tank = 1.25m³/hr
 Number of electrical heating coils for tank = 6
 Total heating coil capacity of tank = 30kW
 LMTD = ((75-65)-(70-65))/ln ((75-65)/ (70-65)) =7.2134K

Forced convection:

Heating coil average temperature = 73°C
 Water flow rate per heating coil= 2.2×10⁻⁵ m³/hr
 Area of tube = $\pi/4 \times (0.0127^2)$
 = 0.00013m²
 Velocity of water in tube = 0.171 m/s
 Reynolds number (Re) = $\rho v d / \mu$
 = (980×0.171×0.0107) / (0.00043)

= 4906.55 (Re>2300)
 Nusselt number (Nu) = 0.023×Re^{0.8} ×Pr^{0.3}
 = 28.48
 Nusselt number = hd/k
 Heat transfer coefficient (h) = (Nu×k) / d
 = 1756.71 W/m²K

Natural convection:

Kinematic viscosity (ν) = μ/ρ
 = 4.3163×10⁻⁴ m²/s
 Volume expansion coefficient (β)
 = 1/ (348.15+338.15) /2
 =2.914×10⁻³
 Raleigh number (Ra) = ($\Delta T \times g \times \beta \times \text{depth}^3$) / ν^2
 =331439.5
 Nusselt number (Nu)
 = 0.6+ { $\frac{0.387 \times Ra^{0.167}}{1 + ((\frac{0.559}{Pr})^{0.5625})^{0.2962}}$ }²
 = 12.2867
 Heat transfer coefficient (h) = (Nu×k) / d
 = 633.672

Friction Factor= $\frac{1}{(1.58 \times \ln Re - 3.28) - 2}$
 = 0.009716
 Overall heat transfer coefficient (U)
 = $[\frac{1}{h_o} + \frac{t}{k} + \frac{1}{h}] + 2 \times (\text{fouling factor})$
 = 418.33 w/m²k
 Heating load = 30kW
 Area of heating coils = $\frac{Q}{U \times (LMTD)}$
 = (30×10³) / (418.33×7.2134)
 = 9.9415 m²
 Surface area of heating coil = $\pi \times D \times L$
 Length of the coil = 263.84 mm

Friction head loss (hf) = $\frac{f \nu^2}{2gd}$
 = $\frac{(0.009716 \times 263.84 \times 0.171 \times 0.171)}{2 \times 9.81 \times 12.7 \times 10^{-3}}$
 =0.301m
 Pressure drop = $\rho \times g \times hf$
 = (1000×9.81×0.301)
 =2952.81pa

Total length of heating coil is 263.84m and manufacturing of the Heating coils done by as per tank dimensions and openings of tank. If the tank dimensions and openings of tank are less then no of heat exchangers coil are increases as well as tank dimensions and openings of tank are high, then no of heat exchangers coils are decreases.

Totally 4 numbers of tanks are available for Machine 1&2 and each tank dimensions is 1.5×0.7×0.6m so as per tank dimensions 4

number of heat exchanger coils are required i.e. 1 heat exchanger coil required for 1 tank and number of passes for each heating coil is 96.

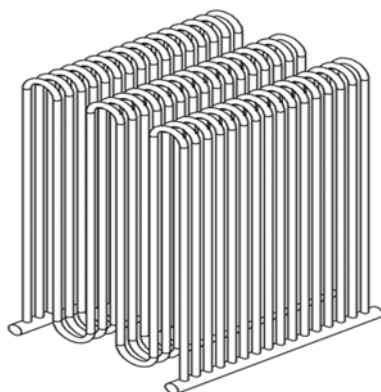

Fig 3.2 shows that Isometric view of Heating coils

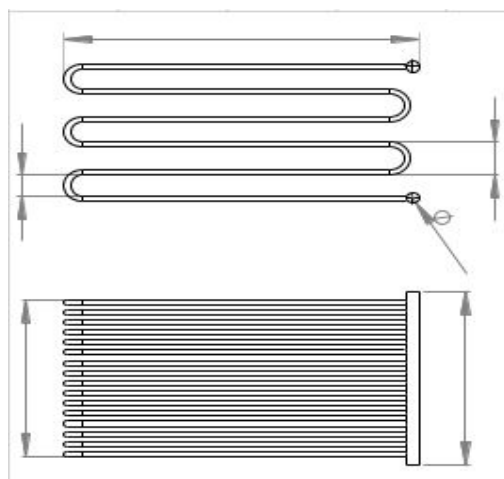

Fig 3.3 shows that Front view of heating coils

Material of Heat exchanger coil is SS316. It is the standard molybdenum-bearing grade, second in importance to 304 amongst the austenitic stainless steels. The molybdenum gives 316 better overall corrosion resistant properties, particularly higher resistance to pitting and crevice corrosion in chloride environments. Excellent in a range of atmospheric environments and many corrosive media. Subject to pitting and crevice corrosion in warm chloride environments, and to stress corrosion cracking above about 60°C. Considered resistant to potable water with up to about 1000mg/L chlorides at ambient temperatures, reducing to about 500mg/L at 60°C.

316 is usually regarded as the standard “marine grade stainless steel”, but it is not resistant to warm sea water. In many marine environments 316 does exhibit surface corrosion, usually visible as brown staining. This is particularly associated with crevices and rough surface finish.

3.9 Circulation pump design:

Heat pump capacity= 30kW
 Set point temperature difference= 5°C
 Mass flow rate of water= $\frac{Q}{C \times \Delta T}$
 = $\frac{30}{4.2 \times 5}$
 = 1.42 m³/s
 Flow rate (Q) = 5m³/hr

3.10 Specification of 30kW Air source Heat Pump:

Table 3.4 30kW Heat Pump specifications

Description	units	Specifications
Heating capacity	kW	30 @ 30 ⁰ c ambient temperature
Rated compressor power input	kW	10.2* @ 60 ⁰ c and 30 ⁰ c ambient temperature
Power supply	V/P/Hz	380/3/50
Compressor quantity	No's	2
Compressor type	-	Scroll
Fan quantity	Nos	2
Fan type	-	Axial
Fan direction	-	Vertical
Heat exchanger	-	Finned tube & shell and tube
Refrigerant	-	H417A
Water temperature limit	⁰ c	75
Ambient temperature limit	⁰ c	-10 to 43
Noise level	dBA	<60
Unit size	mm	1500×750×1390
Unit weight	Kg	272

3.11 Circulation Pump specifications:

Table 3.5 Circulation pump specification

Description	Heat Pump circulation pump
Pump speed	2900rpm
Actual circulated flow	5m ³ /hr
Resulting head of pump	12 meters
Rated power	0.46kW

Pump efficiency	>47%
Pressure rating	10bar
Temperature rating	Up to 90 ⁰ c
Pump efficiency rating	EFF-1

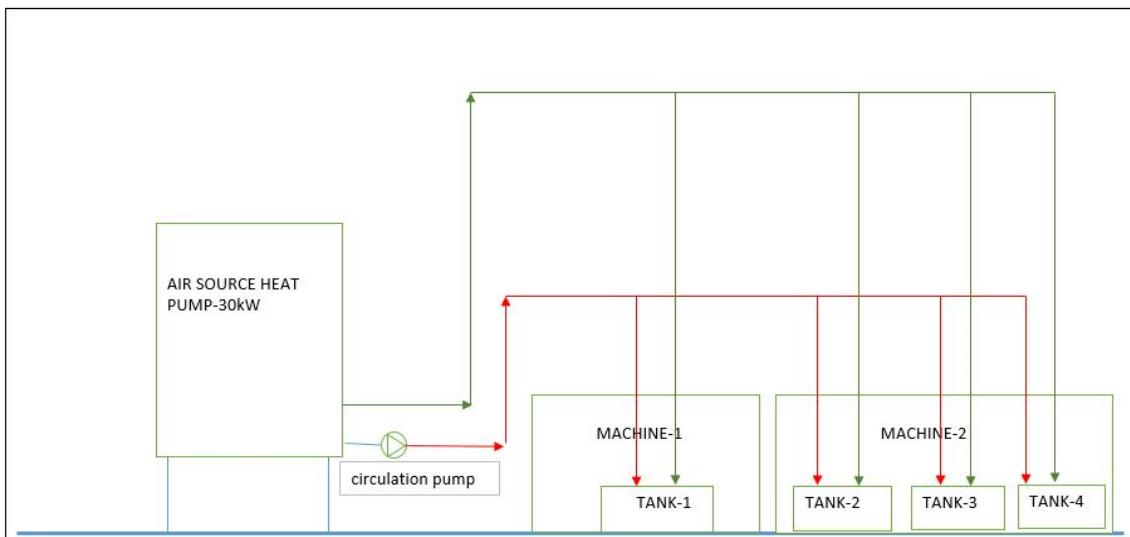

Fig 3.4 shows the piping connection of 30kW Heat Pump to Machine 1&2

4. RESULTS AND DISCUSSIONS

Energy assessment and energy conservation by application of heat pump shows that the operating cost increases with temperature

differences. Cost saving with heat pump technology as compared to electric heater is reported as 49.33%.

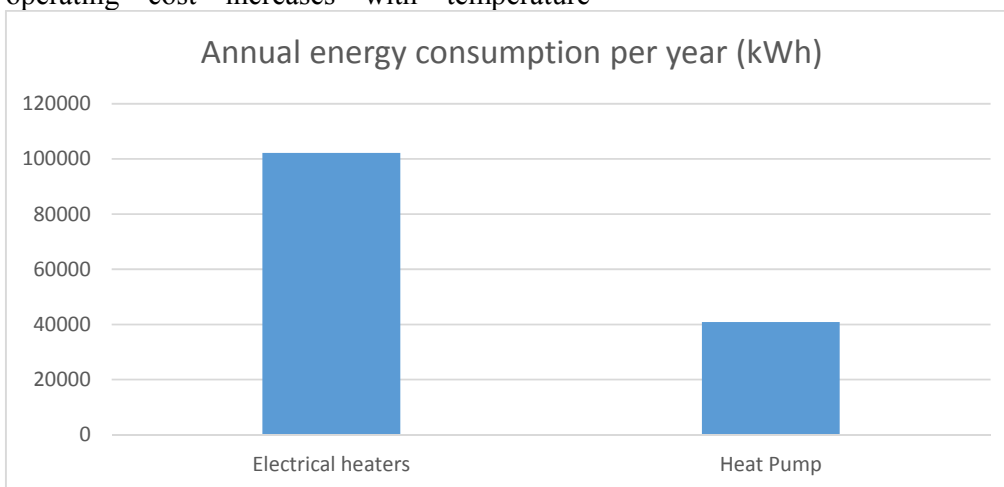

Fig 4.1 Electricity consumption for the heat pump system is almost 1/2.5 as that of compared with electric heater for the same capacity output of heat.

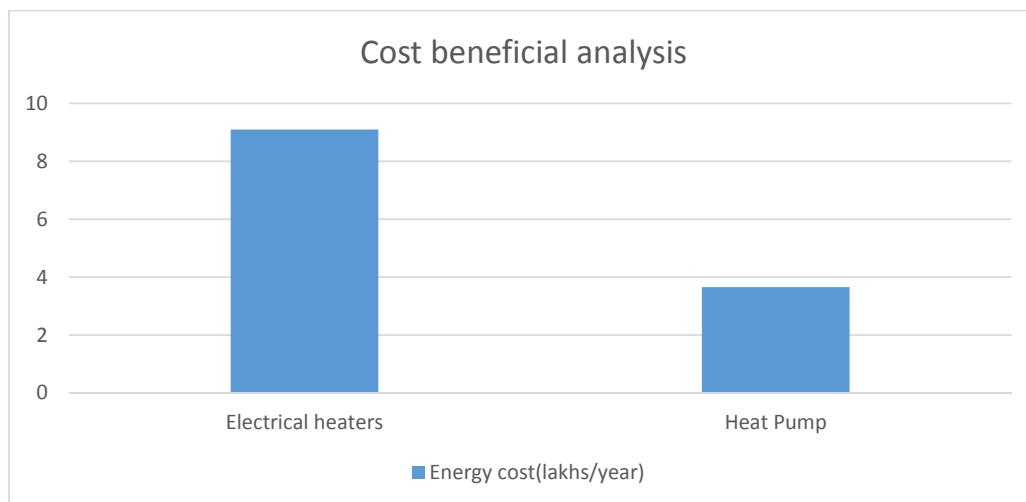

Fig 4.2 The cost of the 30kW Heat Pump is 12 lacks and installation cost 1 lac so that total project cost is around 13 lacks

5. CONCLUSION

The analysis of installed heat pump to meet the demand of supplying hot water to the component washing machine in a process industry having capacity of 2000 lit/day is carried out. The results shows that saving electrical energy units of the order of 102168 kWh/year, which tends to annual saving of an electrical energy to about 49.33%. This also gives an advantage of reduction in CO₂ emissions to the atmosphere.

References

[1] S.N.Nalawade, G.B.Jadhav, N.N.Shinde (2015) "Energy Conservation Analysis by Application of Heat Pump System- A Case Study" International Journal Of Engineering Sciences & Research Technology, Vol 4 Issue 6, pp.951-956.

[2] I. Sarbu, C. Sebarchievici, "General review of ground-source heat pump systems for heating and cooling of buildings", *Energy and Buildings*

(2013), <http://dx.doi.org/10.1016/j.enbuild.2013.11.068>

[3] Hepbasli, A., Kalinci, Y., "A review of heat pump water heating systems". *Journal of Renew Sustain Energy Rev* (2008), doi:10.1016/j.rser.2008.08.002

[4] Turkan Ucok Erkek, Ozay Akdemir, Ali Gungor (2014) "Thermodynamic Performance Study on Water Source Heat Pump in Different Operating Conditions" 7th International Ege Energy Symposium & Exhibition, June 18-20 Usak, Turkey.

[5] Rajnikant S. Jadhao and Tejay V. Lanjewar (2014) "A Review An Industrial Heat Pump For Steam And Fuel Savings" *Sci. Revs. Chem. Commun.:* 4(2), 2014, 46-54 ISSN 2277-2669

[6] B.J. Huang and C.P. Lee(2003) "Long-term performance of solar-assisted heat pump water heater" *Renewable Energy* 29 (2003) 633-639.