



## VOTING SYSTEM USING DIGITIZED PERSONAL TAG

C. Sivamani<sup>1</sup>, E.S. Akshayaa<sup>2</sup>, R. Muthusamy<sup>3</sup>, C. Soundariya<sup>4</sup>

<sup>1</sup>Assistant Professor, <sup>2,3,4</sup>UG Scholar

Department of ECE, Angel College of Engineering & Technology Tirupur

### Abstract

**The smart card based Electronic voting system is introduced to avoid abuse in voting procedure. E-Voting is done using face detection and recognition system as an authentication technique in online voting. As e-voting through online is not possible for illiterate people, this project set up a smart card with Radio Frequency Identification (RFID). The RFID tag contains Name, Date of birth, Address, Gender, Photo, PAN card number, driving license number, Aadhar card number, Voter ID number and Passport Number. The card is read using RFID reader where camera opens and captures the image of the person. The image is checked out with the database provided in RFID Tag. If the sensed image coincides with the image in the database, then the person is authorized to cast the vote. If it flops, the user cannot forecast their vote. A person after enrolling vote and tries to vote once again is block out when the camera captures image.**

**Keywords- Raspberry Pi, Smart card, RFID, RF Tag, Weber's Law**

### [1] INTRODUCTION

In United States of America, the citizens are provided with Green Card. They can use the green card right from purchasing sim card to property. Similarly, in Arab countries, Labour cards are issued for social security of the immigrants. The project stockpiles the database from the citizens of India and put in a single card naming SMART CARD with a Radio Frequency Identification (RFID). The RFID Tag contains information about Name, Date of birth, Address, Gender, Photo, PAN card number, Driving license number, Aadhar card number, Voter ID

number and Passport number. The above mentioned data are store up in Raspberry Pi which acts as a small computer. The RFID Tag is generated with the help of Python language using stockpiled data. The RFID Tag is read out using RFID reader where camera opens and captures the image of the person. The image is checked out with the database provided in RFID Tag. If the captured image coincides with the image in the database, then the person is authorized to cast the vote. If it flops, the user cannot forecast their vote. A person after enrolling vote and tries to vote once again is block out when the camera captures image.

### [2] RELATED WORK

In [1] a novel algorithm based on Non-Negative Matrix Factorization (NMF) was proposed in order to extract precise and meaningful user temporal profiles from log of smart card in a transportation system. The proposed NMF based algorithm allowed natural and informative clustering of the profiles which lead to semantic information on the mobility of the users. The approach was compared with 4 others algorithm and on human scale focused indeed, individual profiles differ quite substantially from group profiles. Experiments were conducted on a 3 months' dataset supplied by the STIF, the Parisian public transport authority and the result was worst due to more number of parameters. A system was oriented by authors in [2] to generate a deformation and transformation of human faces between two images by applying Active Shape models (ASM). Visual studio was developed and open CV libraries were used based on Yao Wei's algorithm ASM model was created with the IMM face database, build the model by applying an algorithm based on image pyramidal

techniques. With the ASM, algorithm was created both images to deform and transform one face into another. The deformation was performed by using Delaunay triangulation in the first frame of one image, and in a continuous 20 steps, by doing weighted sum, the first face is deformed and averaged with the second face which took longer time. The author [3] describes an entirely automated approach for the recognition of the face of a people starting from her/his images. The approach used a computational attention module automatically the most relevant facial features that used the Focus of Attention (FOAs). Those features were used to build the model of a face during the learning phase and for recognition during the testing phase. The landmarking of the features was performed by applying the active contour model (ACM) technique, where the ASM was more flexible of selected facial features. The author [4] describes a depth based face recognition algorithm specially adapted to high range resolution data acquired by the new Microsoft Kinect 2 sensor. A novel descriptor had been designed to make use of the extended range resolution of the new sensor. The introduction of a quantification step, its capacity to increased distinguish different depth patterns. The proposed descriptor had been used to train and test a Support Vector Machine classifier, which had proven to be able to accurately recognize different people faces from a wide range of poses. A new depth-based created and made public to evaluate the proposed face recognition system.

The author [5] described an efficient approach for face recognition as a two-step process: 1) segmenting the face region from an image by using an appearance based model 2) using Eigen faces for person identification for segmented face region. The result was an algorithm that as robust against facial expressions variances. Moreover, it reduced the amount of texture up to 12% of the image texture instead of considering whole face image. The author in [6] aimed to prove how depth maps, can improve face recognition with benchmark algorithm based on the Eigen face. The algorithms were created to recognize faces using normal images that could be as effective if not more effective with depth map images was experimented the Open CV Eigen face algorithm implementation was used for the purpose of training and testing both normal and depth-map images. Results of the

experiments were presented to prove the ability of the tested algorithm to function with depth maps. The author [7] sets of antecedents constructs drawn from both TAM and the Perceived Characteristics of Innovating (PCI) inventory were tested and subsequently compared with one another. The comparison was done in the context of a large-scale market trial of smart card- based electronic payment system being evaluated by a group of retailers and merchants. The PCI set of antecedents explained substantially, also provided the managers with more detailed information regarding the antecedents driving technology innovation adoption. The author [8] surveyed issues relating to usability of electronic voting systems and reported on a series of studies, including one with 415 voters using new systems their analysis showed that systems work well, but have several problems, and a significant minority of voters have concerns about them. The author [9] described the design and implementation through information-flow security analysis. Experimental results gave a quantitative evaluation of the trade-offs between time, cost and security.

### [3] PROPOSED METHOD

The flowchart for carrying out the voting system using digitized personal tag is shown in Figure 1.

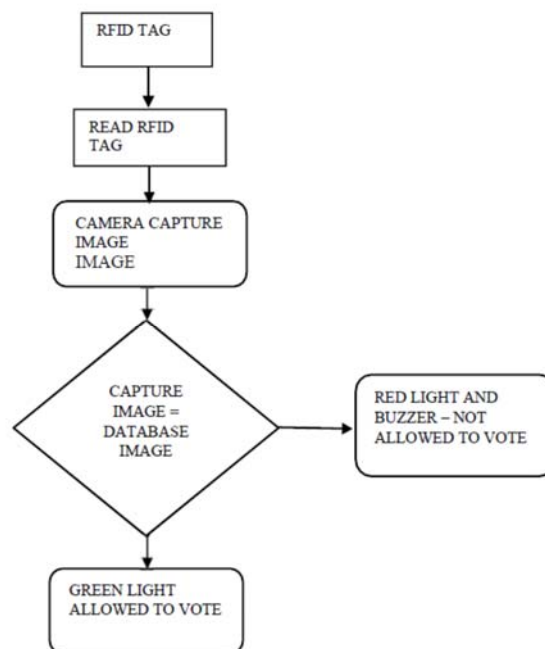

Figure 1

The RFID card is read using the RFID Reader. Once the tag is read, the camera opens and captures the image of the tag user. The image sensed by the camera is compared with the image in the card database. If the image coincides the user is authorized to cast vote else eliminated to cast their vote.

3.1 Block Diagram

The Raspberry Pi contains 40 general purpose input output pins. The micro SD slot, USB port, Camera port, display port are utilized. The RFID reader is connected to USB port via USB to serial port converter. The camera to camera port and display to display port as shown in Figure 2.

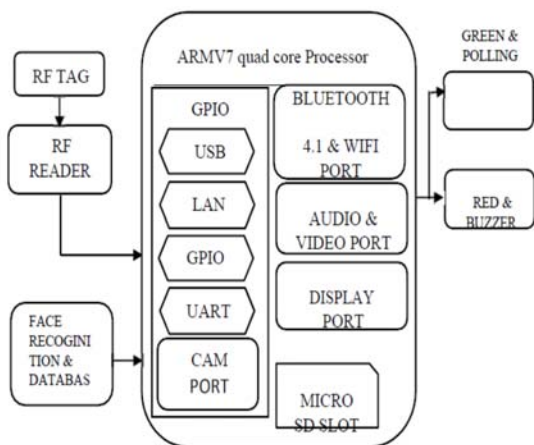

Figure 2

3.2 Interfacing Raspberry Pi with Database

Raspberry Pi shown in Figure 3 is a small credit card sized computer that can perform the functions of CPU. The 3rd version of Raspberry Pi contains 1.2GHZ, 64-bit quad-core ARMv8 processor.

802.11 wireless LAN, Bluetooth 4.1, 4 USB ports, 40 GPIO pins, Camera Interface port, Micro SD card slot, DSI Display port and a video core.



Figure 3

A keyboard and display can be connected and used as a mini computer. The operating system is stored in micro SD card. The details of person such as Name, Date of birth, Address, Gender, Photo, PAN card number, driving license number, Aadhar card number and Passport number are collected and stored in a database.

RFID Tag shown in Figure 4 is a small radio frequency identification device. It is used for identification purpose. There are two types of RFID Tag. They are Active tag and Passive tag. A Passive type of RFID Tag is used in this project.



Figure 4

Python is a general purpose programming language. This language is user friendly, ease of understanding and its flexibility make it easy to work. It has a design philosophy that emphasizes code readability. So python programming is used to interface RFID with Raspberry Pi. RFID uses electromagnetic fields to read, monitor and transfer data from tags to Raspberry Pi. EM-18 RFID Module shown in Figure 5 is used to read the RFID Tag. The RFID Tag is generated with the help of Python language using stockpiled data in Raspberry Pi.



Figure 5

The details of a citizen of India such as Name, Date of birth, Address, Gender, Photo, PAN card number, driving license number, Aadhar card number and Passport number are stored in RFID Tag named SAMART CARD.

Camera Interface for Face Recognition

The camera module is available in Raspberry Pi. It can be interfaced with the help of python code. Once the smart card is read using the EM-18 reader module, the camera opens and captures the image of the person. The Weber's law is applied. The law states that the change in a stimulus that will be just noticeable is a constant ratio of the original stimulus. The ratio of the increment threshold to the background intensity is a constant as shown in Figure 6. The thresholds increase in proportion to the background. When the thresholds on various intensity background is incremented.

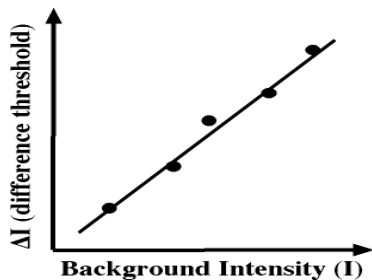

Figure 6

$$\frac{\Delta I}{I} = k \quad \rightarrow 1$$

The 1st equation is the Weber's Equation. Where  $\Delta I$  – is the difference in intensity,  $I$  - is the intensity,  $K$  – is the Weber's constant.

Weber's Law is good to compare performance and as a Rule of thumb as shown in 2nd equation.

$$\frac{\Delta I}{I+a} = k \quad \rightarrow 2$$

Where  $\Delta I$  – is the difference in intensity,  $I$  - is the intensity,  $K$  – is the Weber's constant,  $a$  – is a constant.

By this law, the captured image is verified with the image in the smart card.

Polling Section Interface

When the image sensed by camera and the image in the database coincides, a green light will glow and the user is authorized to cast their vote. If it flops, the user cannot forecast their vote. A person after enrolling vote and tries to vote once again is block out when the camera captures image.

[4] RESULT

The result of this project is shown in Figure 7

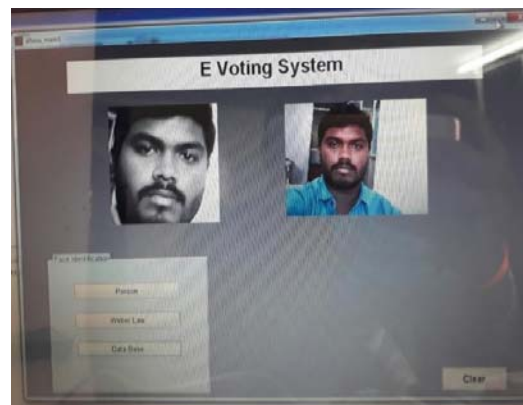

Figure 7

When the camera captures image the output will display as shown in Figure 7

When the image coincides with the image in the database then the output will appear as shown in Figure 8

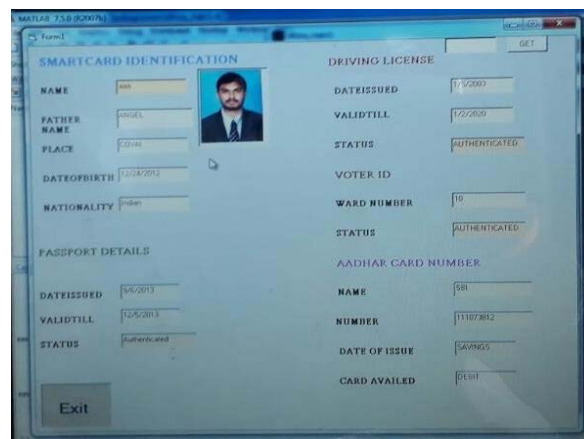

Figure 8

[5] CONCLUSION AND FUTURE WORK

The world is becoming digitized now. As a stepping stone we have created a digitized method for voting system which avoids malpractices. A smart card that contains the Name, Date of birth, Address, Gender, Photo, PAN card number, driving license number,

Aadhar card number, Voter ID number and Passport number with a RFID Tag was created. The RFID Tag was read using the RFID reader where camera opens and captures the image of the person. The image was compared with the database provided in RFID Tag. When the sensed image coincides with the image in the database, then the person was authorized to cast the vote. If it flops, the user was not allowed to forecast their vote. A person after enrolling vote and tries to vote once again was blocked out when the camera captures image.

In future the same card adding up a microprocessor on board so that data will be highly secure in offline processing that contain the details about the account number, card number etc., and used for banking purpose.

## **[6] REFERENCES**

- [1] Emeric Tonnelier, Nicolas Baskiotis, Vincent Guigue and Patrick Gallinari," Smart Card in Public Transportation: Designing an Analysis at the Human Scale", 2016 IEEE International Conference on ITCS.
- [2] Carlos H. Esparza F., Juan P. Tinoco S., Carlos A. Pabon R.," Face Deformation System Based on Active Shape Models", 2016 IEEE International Conference.
- [3] A. Faro, D. Giordano, C. Spampinato," An Automated Tool for Face Recognition using Visual Attention and Active Shape Models Analysis", 28th IEEE International Conference.
- [4] Tomas Mantecon, Carlos R. del-Blanco, Fernando Jaureguizar, Narciso Garcia." Depth Based Face Recognition Using Local Quantized Patterns Adapted for Range Data", 2014 IEEE International Conference.
- [5] Zahid Riaz, Michael Beetz, Bernd Radig," Shape Invariant Recognition of Segmented Human Face Images using Eigenvalues", 2008 IEEE International Conference.
- [6] Yaser Saleh, Eran Edirisinghe," Novel Approach to Enhance Face Recognition Using Depth Maps", 2016 23rd IEEE International Conference.
- [7] Christopher R. Plouffe, John S.Hulland, Mark Vandenbosch," Richness Versus Parsimony in Modelling Technology Adoption Decisions-Understanding Merchant Adoption of a Smart Caerd Payment system", June 2001 INFORMS Vol.12,No.2, pp. 208-222.

[8] Benjamin B. Bederson, Paul S. Herrnson, Richard G. Niemi," Electronic Voting System Usability Issues.

[9] Michael R. Clarkson, Stephen Chong, Andrew C. Myers," Civitas: Toward a Secure Voting System".s