



CUCKOO SEARCH ALGORITHM BASED CURRENT CONTROL TECHNIQUE FOR HARMONIC REDUCTION IN NON-LINEAR LOADS

Dr. T. Parithimarkalaigan¹, Dr. R. Reka², Dr. N. Dhasarathan³

¹Principal, Annai Mathammal Sheela Engineering College, Namakkal, Tamil Nadu, India.

²Professor & Head, Department of Computer Science & Engineering, Annai Mathammal Sheela Engineering College, Namakkal, Tamil Nadu, India.

³Associate Professor, Department of Electronics & Communication Engineering, P.R. Engineering College, Thanjavur, Tamil Nadu, India.

Abstract

This paper deals with a Cuckoo Search Algorithm based current control technique for the power quality enhancement. The shunt hybrid filter has its establishment on harmonic reduction and can be used for nonlinear loads. The reference current extraction is by means of stationary “abc” reference frame and then transformed to orthogonal “dq” transformation. A proportional-integral control system is derived through linearization of nonlinear shunt active filter system model, so that the task of current control dynamics and DC capacitor voltage dynamics become dissociated. The Proportional Integral controllers are used to control the DC bus link voltage and to control the shunt hybrid filter input currents. The currents track closely their references so that the shunt hybrid filter behaves as a quasi-ideal current source connected in parallel with the load. It compensates the reactive power and harmonic currents required by the non linear load, thereby achieving sinusoidal supply currents in phase with supply voltage both dynamic and steady-state conditions. The shunt hybrid filter is implemented with three phase current controlled Voltage Source Inverter for compensating the current harmonics by injecting equal but opposite filter currents. The soft computing algorithms have proved their superiority in giving better results by improving the THD minimization and other performance indices. The proposed

filter maintains the THD threshold as recommended by IEEE-519 standards. This proposed technique is implemented in MATLAB simulink software.

Keywords: Harmonic compensation, Shunt hybrid filter, dissociated current control, Cuckoo Search Algorithm (CSA)

NOMENCLATURE

V1, V2, V3 – Source voltages
Ls – Source Inductance of the Shunt Hybrid filter
LP, RP, CP - Inductance, Resistance & Capacitance of Passive filter
ZP- Impedance of Passive filter
VAN- Voltage of Shunt Active filter
Cdc –DC capacitor current
id – active current of Active filter
iq –reactive current of Active filter
Sc1, Sc2 –apparent power of shunt active filter
SL1, SL2 – apparent power of load
Kp, Ki –Control parameters of Proportional Integral controller
RL-CL- Voltage source type of non linear load
RL-IL - Current source type of non linear load
qnd - reactive component of direct axes
qnq- reactive component of quadrature axes
UAq- Active filter voltage

I. Introduction

The past few years had seen the handling of power electronic devices for non linear loads resulting in harmonics and power quality disturbances in the utility systems. The harmonics distort the supply voltage at the

customer side. Usually passive filters have been used to eliminate the line current harmonics and to improve the load power factor. Though in practical applications these traditional filters give disadvantages such as aging and tuning problems, series and parallel resonance and the requirement to implement one filter per harmonics that needs to be eliminated. In order to avoid these difficulties, different kinds of active power filters based on force commutated devices have been researched and developed. Particularly shunt active filters with various control techniques have been widely investigated [1]-[3]. The shunt active filter needs high DC link voltage in order to effectively compensate the higher order harmonics. On the other hand, a series active filter requires a transformer that is capable to withstand full load current in order to balance for voltage distortion [4]. One more resolution for the harmonic problem is to utilize a hybrid filter and it successfully alleviate the problems of a passive filters and active filters and provide profitable in harmonic compensation particularly for high power nonlinear loads. A hybrid power filter system consists of a lower rating active filter in series with a passive filter. The active filter act as a harmonic compensator for the load by confining all the harmonic currents into the passive filter thereby reducing the resonance problems [5], [6]. CSA based dissociated current control technique is proposed to enhance the dynamic performance of a shunt hybrid power filter which is modeled in synchronous orthogonal “dq” frame. The feedback linearization theory is applied in the design of the controller. This control strategy allows the decoupling of the currents and enhances their tracking behavior and improves dc regulation.

II. Proposed Control strategies

The 3 phase hybrid filter connected in between the source and the nonlinear load which is three phase diode bridge rectifier. The hybrid filter act as a controlled current source connected in parallel with nonlinear load shown in Figure. 1. It consists of a full bridge voltage source pulse width modulated inverter, high frequency inductors and DC side capacitors that are required to shape the compensator currents. The Shunt active power filter is represented as A.

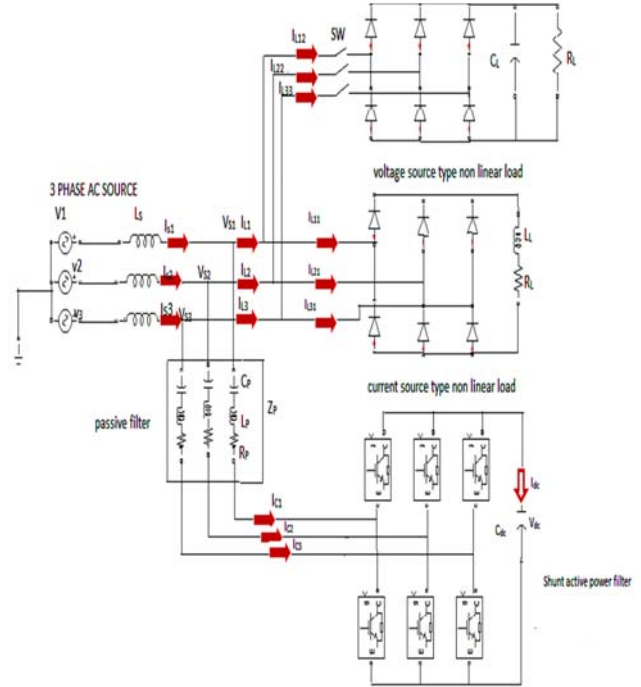

Fig.1. Basic circuit of Shunt Hybrid Power filter

II.1. Extraction of reference current

By adopting KVL and KCL to this system, the three differential equations in the stationary reference frame (for k=1, 2, 3) are as follows.

$$V_{sk} = L_p \frac{di_{ck}}{dt} + R_p i_{ck} + \frac{1}{C_p} \int i_{ck} dt + v_{kA} + v_{AN} \quad (1)$$

By differentiating the equation (1) we get

$$\frac{dv_{sk}}{dt} = L_p \frac{d^2 i_{ck}}{dt^2} + R_p \frac{di_{ck}}{dt} + \frac{1}{C_p} i_{ck} + \frac{dv_{kA}}{dt} + \frac{dv_{AN}}{dt} \quad (2)$$

By calculating the sum of the three equations included in (2), and considering the absence of the zero sequence current into a three-wire system, and with the assumption that the source voltages are balanced, the following relation is obtained:

$$v_{AN} = -\frac{1}{3} \sum_{k=1}^3 v_{kA} \quad (3)$$

The switching function c_k (for k= 1, 2, 3) is defined as

$$c_k = \begin{cases} 1, & \text{if } s_k \text{ is on and } s_k^1 \text{ is off} \\ 0, & \text{if } s_k \text{ is off and } s_k^1 \text{ is on} \end{cases} \quad (4)$$

Finally the “abc” reference frame is obtained and it is given in (5)

$$L_P \frac{d^2 i_{c1}}{dt^2} = -R_P \frac{di_{c1}}{dt} + \frac{1}{C_P} i_{c1} - q_{n1} \frac{dv_{dc}}{dt} + \frac{dv_{s1}}{dt}$$

$$L_P \frac{d^2 i_{c2}}{dt^2} = -R_P \frac{di_{c2}}{dt} + \frac{1}{C_P} i_{c2} - q_{n2} \frac{dv_{dc}}{dt} + \frac{dv_{s2}}{dt}$$

$$C_{dc} \frac{dv_{dc}}{dt} = (2q_{n1} + q_{n2})i_{c1} + (q_{n1} + 2q_{n2})i_{c2} \quad (5)$$

The dynamic model in the dq frame is as follows

$$L_P \frac{d^2 i_d}{dt^2} = -R_P \frac{di_d}{dt} + 2\omega L_P \frac{di_q}{dt} - X i_d + \omega R_P i_q - Y + \frac{dv_d}{dt} - \omega v_q$$

$$L_P \frac{d^2 i_q}{dt^2} = -R_P \frac{di_q}{dt} - 2\omega L_P \frac{di_d}{dt} - \omega R_P i_d - X i_q - Y + \frac{dv_q}{dt} + \omega v_d$$

$$C_{dc} \frac{dv_{dc}}{dt} = (q_{nd} i_d + q_{nq} i_q) \quad (6)$$

II.2. Dissociated Current Control methodology

A PI control law was derived through linearization of Shunt hybrid power filter, thereby decoupling the tasks of harmonic load currents tracking and dc side voltage regulation. The decoupling allows the filter to compensate for the ac currents and the dc bus voltage independently of each other. In order to obtain fast response of current compensation, the current controller loop and dc voltage controller loop is adopted and it is shown in figure 2 and 3. The current control rule is designed to have a rapid response than the dc voltage control rule. [8]

Accordingly the first two equations in the model (6) are written as following.

$$L_P \frac{d^2 i_d}{dt^2} + R_P \frac{di_d}{dt} + X i_d = 2\omega L_P \frac{di_q}{dt} + \omega R_P i_q - Y + \frac{dv_d}{dt} - \omega v_q$$

$$L_P \frac{d^2 i_q}{dt^2} + R_P \frac{di_q}{dt} + X i_q = 2\omega L_P \frac{di_d}{dt} + \omega R_P i_d - Y + \frac{dv_d}{dt} + \omega v_d$$

$$\text{Where } X = \left(-\omega^2 L_P + \frac{1}{C_P}\right) i_d \text{ and } Y = q_{nd} \frac{dv_{dc}}{dt} \quad (7)$$

Such that the following input equations can be defined:

$$u_d = 2\omega L_P \frac{di_q}{dt} + \omega R_P i_q - q_{nd} \frac{dv_{dc}}{dt} + \frac{dv_d}{dt} - \omega v_q$$

$$u_q = -2\omega L_P \frac{di_d}{dt} - \omega R_P i_d - q_{nd} \frac{dv_{dc}}{dt} + \frac{dv_q}{dt} + \omega v_d \quad (8)$$

Through the transformation given in (8), the coupling dynamics of the current tracking have been transformed to dissociated dynamics. By using error signals and applying PI compensation u_d and u_q are chosen that

$$u_d = k_p i_d + k_i \int i_d dt$$

$$u_q = k_p i_q + k_i \int i_q dt \quad (9)$$

The transfer function of PI controller is given as

$$G_i(s) = k_p + \frac{k_i}{s} \quad (10)$$

And the closed loop transfer function of the current loop is

$$\frac{I_q(s)}{I_q^*(s)} = \frac{I_d(s)}{I_d^*(s)} = \frac{k_p}{L_P} \quad (11)$$

$$\frac{I_q(s)}{I_q^*(s)} = \frac{s + \left(\frac{k_i}{k_p}\right)}{s^3 + \frac{R_P}{L_P} s^2 + W s + \frac{k_i}{L_P}}$$

$$\text{where } W = \left(\frac{1}{C_P L_P} - \omega^2 + \frac{k_p}{L_P}\right) \quad (12)$$

From equation (6)

$$C_{dc} \frac{dv_c}{dt} = q_{nq} i_q \quad (13)$$

An equivalent input U_{dc} is defined as

$$u_{dc} = q_{nq} i_q \quad (14)$$

Thus the reactive current of the active filter is

$$i_q = \frac{u_{dc}}{q_{nq}} = \frac{u_{dc} v_{dc}}{q_{nq} v_{dc}} \quad (15)$$

However, assuming that the current loop is ideal and in normal operation of the active filter, the following properties hold

$$q_{nq} v_{dc} = U_{Aq} \text{ and } q_{nd} v_{dc} = U_{Ad}$$

$$i_q = \frac{u_{dc} v_{dc}}{U_{Aq}} \quad (16)$$

The q is active filter voltage U_{Aq} is given by.

$$U_{Aq} = -Z_p i_{q1}^* \quad (17)$$

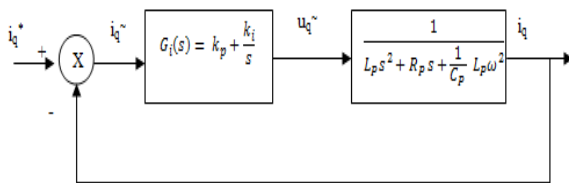

Fig.2. Current controller of Shunt hybrid filter.

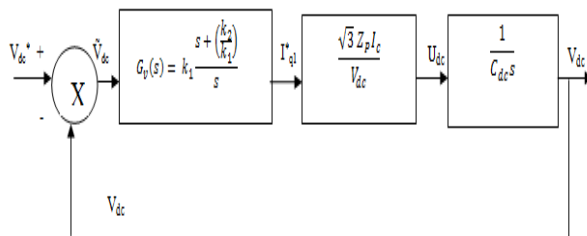

Fig.3. Voltage controller of shunt hybrid filter. Where Z_p is the impedance of the passive filter at 60 Hz and i_{q1}^* is a dc component.

The control effort of the dc-voltage loop is

$$i_{q1}^* = \frac{v_{dc}}{-Z_{pF1}} v_{dc} \quad (18)$$

The fundamental filter rms current I_c is given by

$$I_c = \frac{i_q}{\sqrt{3}} \quad (19)$$

$$I_{q1}^* (s) = \frac{v_{dc}}{\sqrt{3}} \frac{V_{dc}(s)}{Z_p I_c} \quad (20)$$

III. Design of Shunt hybrid filter

To devise the control system and harmonic reference current generator, the transformation method is used due to its advantages to attain harmonic cancellation and thus obtain high performance of the controller. The instantaneous reference current must be coordinated with voltages V_{a123} (V_{a1} , v_{a2} and V_{a3}). This is obtained through PLL, which indicates the instantaneous phase of voltages V_{a123} . This is obtained as observed in Fig. 4. The current i^*_{L123} (i^*_{L1} , i^*_{L2} and i^*_{L3}) is converted to i^*_{Ldq} (i^*_{Ldh} and i^*_{Lqh}) using the Park's transformation, the low-pass filter (LPF) is applied in the current i^*_q , which gives the current of the filter (i^*_q) with the same frequency of the grid. The fundamental voltage produced by an active filter is being in phase with the fundamental leading current of the passive filter. It delivers to the dc capacitor a small amount of active power formed by the leading current and the fundamental voltage. Therefore, the current adjusted by the dc-voltage controller is consequently i^*_{q1} . For maintaining the DC link voltage v_{dc} equal to its reference value, the losses through the active power filter's R-L branches will be compensated by acting on the supply current. The major part of the compensation in the shunt hybrid filter is supported by passive filter in association with the active filter which improves the filtering characteristics and damps the effect of resonance in between the source and the passive filter. Hence no voltage is applied to the active filter results in reduction of voltage rating of hybrid filter.

III.1. Case of R-L type current source of nonlinear load.

The filtering performance of shunt hybrid filter is strongly affected by the DC link source voltage. Choosing the higher value of DC link voltage results better reduction in the value of THD with minimum value of rms current of the filter. The hybrid power filter is used effectively to compensate the harmonic currents produced by current source type nonlinear load. The apparent power of shunt active filter is as follows.

$$S_{c1} = I_{rms1} \frac{\sqrt{3}}{\sqrt{2}} V_{dc} =$$

$$5.67 * \frac{\sqrt{3}}{\sqrt{2}} * 50 = 347.52 \text{ VA} \quad (21)$$

The DC link voltage is selected to be 50V and Irms is only 5.67 A for the required hybrid filter.

The apparent power of the load is given by

$$S_{L1} = 3V_{rms}I_{rms} = 3 * \frac{310}{\sqrt{3}} * 10.19 = 5471.53 \text{ VA} \quad (22)$$

The apparent power ratio of the Shunt active filter and the R-L source type of non linear load is

$$\frac{S_{c1}}{S_{L1}} = \frac{347.52}{5471.53} = 6.35\% \quad (23)$$

The rating of the shunt active filter is remarkably reduced to 6.35% of the current-source type of nonlinear load.

III.2. Case of R-C type voltage source of non linear load.

The rating of the hybrid power filter is greatly reduced when compared to the conventional active and passive filters. And also it reduces the overall cost of the compensation system by minimizing the switching ripples, EMI problems and attains higher efficiency.

$$S_{c2} = I_{rms2} \frac{\sqrt{3}}{\sqrt{2}} V_{dc} = 6.632 * \frac{\sqrt{3}}{\sqrt{2}} * 50 = 406.12 \text{ VA} \quad (24)$$

The DC link voltage is selected to be 50V and Irms is only 6.632 A for the required hybrid filter.

The apparent power of the load is given by

$$S_{L2} = 3V_{rms}I_{rms} = 3 * \frac{310}{\sqrt{3}} * 10.9 = 5852.77 \text{ VA.} \quad (25)$$

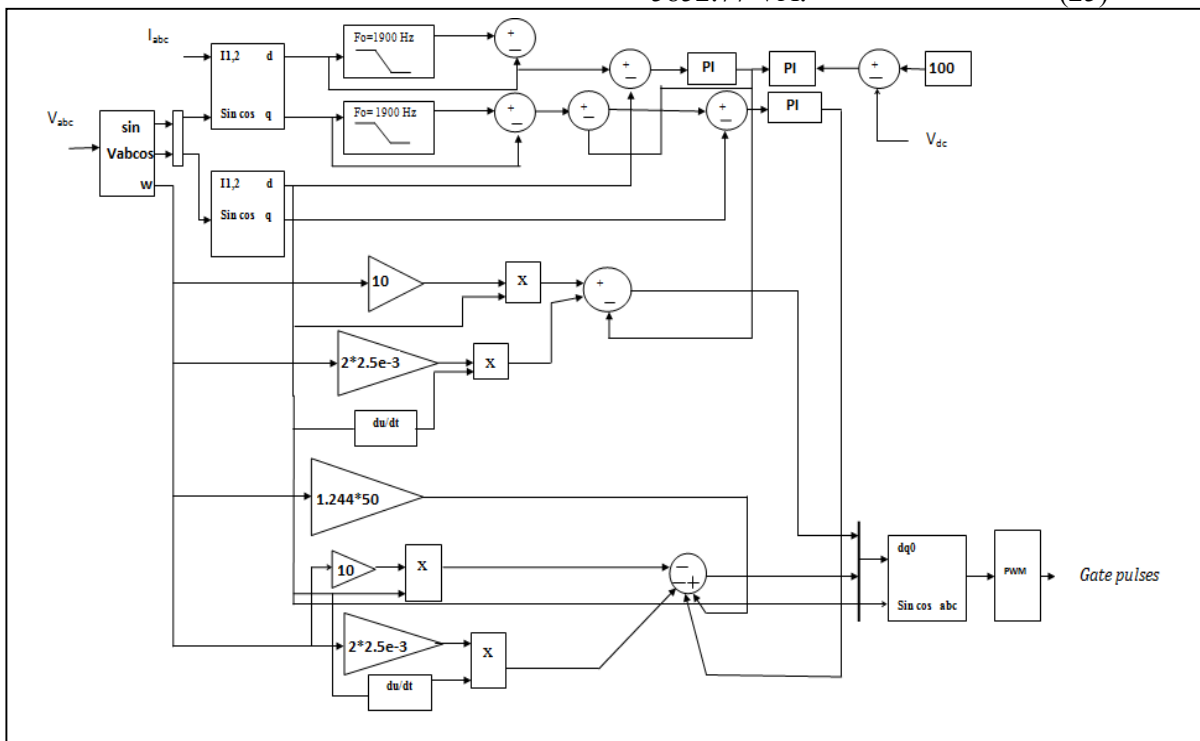

Fig.4 Design of Shunt hybrid filter with Dissociated Current Control technique

The apparent power ratio of the Shunt active filter and the R-L source type of non linear load is

$$\frac{S_{c2}}{S_{L2}} = \frac{406.12}{5852.77} = 6.9\% \quad (26)$$

IV. Problem Formulation

The Proportional Integral (PI) controllers have two parameters K_p and K_i with sampling time.

The values of K_p and K_i are selected iteratively in many literatures using any of the method available for tuning it.[9] Here the K_p and K_i is selected arbitrarily and iterated intuitively. The THD value minimization is taken as the objective and the problem becomes nonlinear due to variation of THD with respect to various K_p and K_i values. The mean value of THD is taken as the objective as shown in the below

equation. The problem is defined for Shunt Active and Hybrid Filters. The PI controller equation at DC link voltage control part in Shunt Active Filter is defined as follows

$$I_{af} = K_p * (V_{dcref} - V_{dc\ measured}) + K_i * \int_0^t (V_{dcref} - V_{dc\ measured}) dt \quad (27)$$

Where I_{af} is Compensation current, $V_{dc\ measured}$ is DC measured voltage at DC link, V_{dcref} is DC reference voltage, K_p is Proportional constant and K_i is Integral constant.

The Objective function is Minimize $\sum_{i=0}^n mean(THD)$ (28)

Subjected to

$$P_1 \leq K_p \leq P_2 \quad (29)$$

$$I_1 \leq K_i \leq I_2 \quad (30)$$

Here, P_1 refers lower limit of K_p value, P_2 refers upper limit of K_p value, I_1 refers lower limit of K_i value and I_2 refers upper limit of K_i value.

The PI controller of Shunt Hybrid filter is defined as below

$$V_d = K_p * (I_{dref} - I_d) + K_i * \int_0^t (I_{dref} - I_d) dt \quad (31)$$

$$V_q = K_p * (I_{qref} - I_q) + K_i * \int_0^t (I_{qref} - I_q) dt \quad (32)$$

Where V_d is direct axis voltage taken out from PI controller, V_q is quadrature axis voltage measured from supply, I_{dref} is direct axis reference current, I_{qref} is quadrature axis reference current, I_d is direct axis current, I_q is quadrature axis current. The equation (31), (32) states the PI controller equation, which is used in the place of real and reactive power component respectively, direct and quadrature axis current error proportionate with direct and quadrature axis voltage.

IV. Simulation Results

The entire system model was built for proving the performance of the dissociated current control technique based shunt hybrid filter using Matlab 2010b version. The simulation has been carried out for voltage source type of nonlinear load. The results have been used to analyze the Total Harmonic Distortion of source currents in dynamic load conditions. Generally non linear loads are time varying in nature. In reality it is necessary to analyze the dynamic performance of Shunt hybrid filter when variations in the non linear loads are considered. Figure 5 represents

the waveforms of source voltage, source current and load voltage, load current for non linear load and Figure 6 represents the FFT analysis of harmonic compensation using Hybrid filter.

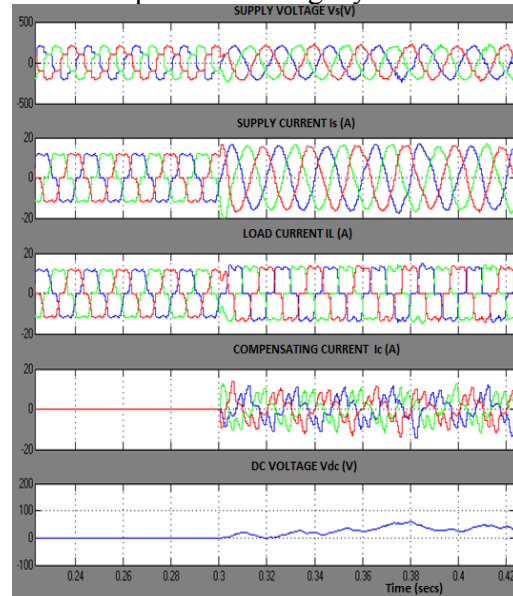

Fig.5 Dynamic response of SAF for an R-L type of non linear load

The disturbances due to non linear load in source current and load current could be realized in the time interval from $t=0.22$ to 0.3 seconds. After connecting Shunt Hybrid filter the disturbance due to the non linear load is removed and could be realized in the source current waveform shown in Figure 4.6 which is suitable for any power system. The current injection due to the Shunt hybrid filter has proved its significance.

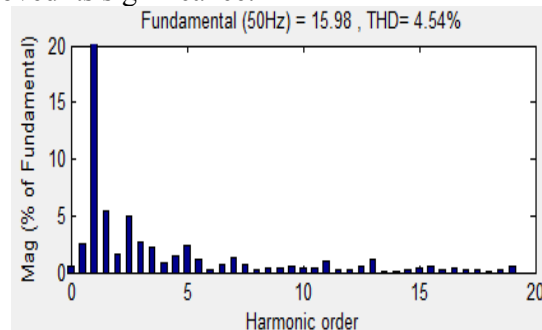

Fig.6 Spectrum of supply current in phase 1 for R-L load after compensation.

In Artificial Intelligence, Cuckoo Search Algorithm (CSA) is a computational method that optimizes a problem by iteratively trying to improve a candidate solution with regard to a given measure of quality solutions [10]. A Matlab Program is written naming fitness taking

the overall objective function. This fitness is linked to another Matlab program named CSA. This CSA program consists of population size is 20 and number of iterations are taken as 50 because the more the number of iterations, the more is the chance of getting the best solution.. The values of K_p and K_i and fitness function corresponds to the error in DC link.

Parameters Used:

- 1) Objective Function: mean(THD) in %
- 2) Population Size(HMS)=20
- 3) Number of Variables=2
- 4) PAR=1(Pitch Adjustment Rate)
- 5) Beta(β)=1.5
- 6) Range of Variables:
 $K_p = 0 < v_1 < 10$, $K_i = 0 < v_1 < 10$
- 7) Maximum Iteration=50
- 8) Global Best Solution:
 $K_p = 3.829658$, $K_i = 3.255726$
- 9) Global Best THD=0.511719
- 10) Execution Time=4586.905211 seconds
- 11) System Parameters: 3.3GHz Intel i5 Processor with 4GB RAM

The THD value of 0.5117% is obtained using CSA for 50 epochs and 20 numbers of populations. The best value of K_p and K_i are 3.8297 and 3.2557 respectively. The execution time is 4586.905 milliseconds.

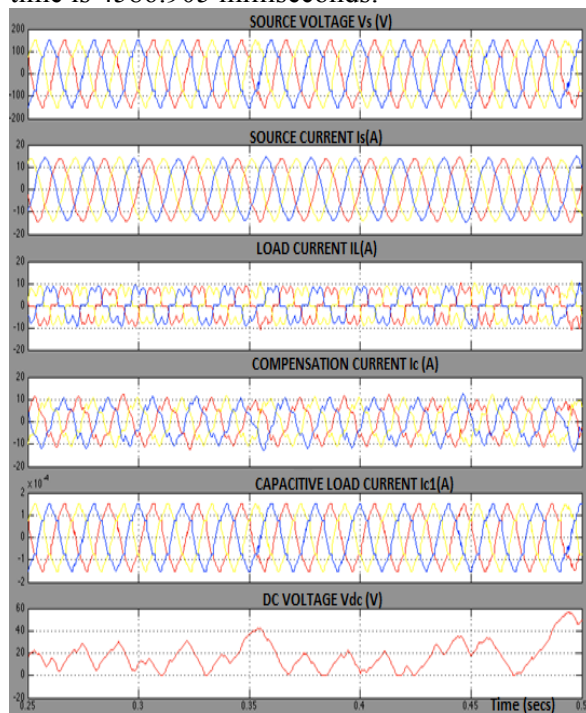

Fig.7 Response of SHF using CSA algorithm

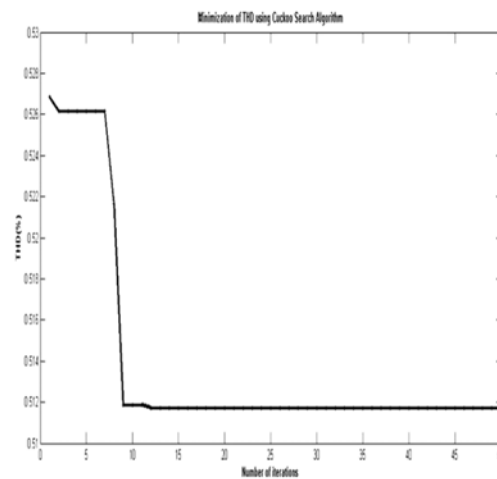

Fig.8 Convergence Characteristics of CSA for Shunt Hybrid Filter design

CONCLUSION

This research paper has proposed a novel current control technique with CSA which is developed for minimizing current harmonics and enhancing the power quality. Herein both Shunt active and Shunt hybrid filters are taken into consideration for research. The rating of Shunt active filter is minimized. The minimization of THD for a shunt active filter and shunt hybrid filters are designed. The parameters of the K_p and K_i are chosen and the results of the circuits are studied using MATLAB software. The range of K_p and K_i values are chosen and it is solved using CSA based on populations and the results are obtained. The MATLAB coding is done for implementation of the algorithm and Simulink and Simpower system toolboxes are used to model the shunt active and hybrid filters.

These filters are giving better results of THD value using non linear loads is in the IEC acceptable range. By analyzing with conventional Shunt Active filter, Shunt Hybrid Filter and CSA based Shunt Hybrid Filter, the best results found using CSA for Shunt Hybrid Filter is depicted in the convergence diagram Figure 7 and Figure 8. All among the types of implemented system the Shunt hybrid filter with CSA is giving the better THD value of 0.5117 than other type of filters. By decreasing the switching frequency and the time conservation for selecting the optimal values of the controller, CSA plays a vital role.

TABLE I
SPECIFICATIONS

Phase Voltage & frequency	178V(rms),50 Hz
Line impedance	$R_s=0.1 \Omega$, $L_s=0.5\text{mH}$
R-C load	$R_L=32\Omega$, $C_L=1000\text{mF}$
R-L load	$R_L=26\Omega$, $L_L=10\text{mH}$
Passive filters	$L_p=5.5\text{mH}$, $C=204 \mu\text{F}$
DC bus voltage & capacitance	$V_{dc}=50\text{V}$, $C_{dc}=3000 \text{mF}$
Inner control parameter	$K_p=45.52$, $K_i=616850$
Outer control parameters	$k_1=14.707$, $k_2=5.37$

REFERENCES

- [1] H.Akagi, Y.Kanazawa, and A.Nabae, "Instantaneous reactive power compensators comprising switching devices without energy storage components," IEEE Trans.Ind.Applicat., Vol.1A-20,pp-625-630, May/June 1984.
- [2] H.Akagi, A.Nabae.and S.Atoh, "Control strategy of active power filters using multiple-voltage source PWM converters," IEEE Trans.Ind.Applicat., Vol.1A-20, pp.460-465, May/June 1986.
- [3] Juan W. Dixon, Jose M.Contardo and Luis A.Moran, "A Fuzzy-Controlled Active front-end rectifier with current harmonic filtering characteristics and minimum sensing variables," IEEE Trans. on Power electronics, Vol. 14, No. 4, pp. 724-729, July 1999.
- [4] S.Inoue, T.Shimizu, and Kawaka, "Control methods and compensation characteristics of a series filter for a neutral conductor, IEEE Trans.Ind.Electron", vol.54, no.1, pp.433-440, Feb.2007.
- [5] S.Srianthumrong and H.Agaki, "A medium voltage Transformerless AC/DC power conversion system consisting of a diode rectifier and a shunt hybrid filter," IEEE Trans.Ind.Appl., Vol.39, No. 3, pp 874-882, May/June 2003.
- [6] H.Fujitha and H.Akagi, "A hybrid active filter for damping of harmonic resonance in industrial power systems," IEEE Trans.Power Electron., Vol.15, no.2, pp215-222, Mar.2000.

[7] M.El-Habrouk and M.K.darwish, "A new control technique for active power filters using a combined genetic algorithm conventional analysis," IEEE Transactions on Industrial Electronics, Vol.49, no.1, pp.58-66, Feb.2002.

[8] T.Parithimarkalaignan, J.Senthilkumar and Y.Suresh, "A Novel dissociated current control technique for harmonic minimization in non-linear loads," International Review on Modelling and simulations, Vol.7 no.1, pp 125-131, Feb.2014.

[9] Parithimar kalaignan, T, Senthilkumar, J, Suresh, Y, 2014, 'PSO and GA based Performance Optimization of PI controller in three phase Shunt Hybrid Filter', International Journal of Engineering Research and Technology, vol. 3, no.8, pp. 255-260, August 2014.

[10] Mr. Lijo Jacob Varghese and B. Joe Maraivanan, "Harmonic elimination in Multi level inverters using Cuckoo Search Algorithm," Advance in natural and applied sciences,, Vol.11,no.3, pp 190-198, March 2017.