



MODELING AND STRUCTURAL ANALYSIS OF BUILT IN SUSPENSION SYSTEM FOR TYRERIM

B. Sandhya Rani, RAJESHWAR SANGU, V.SARITHA
4.D.BHARATH, 5.K.MOUNIKA

Assistant professor Department of Mechanical Engineering, Ellenki College of Engineering and Technology, Hyderabad, India-502319.

E-mail address: sandhyasanju@gmail.com

Abstract: Power transmission systems are being extensively used for transmission of power between members. Once a specific transmission gadget is found out it wishes to be qualified earlier than its route of application. As part of this supposed torque of the transmission systems desires to be measured and tested. Conventional method of dynamic characterization of energy transmission machine has got the demerit of strength consumption to a greater extent. Because of this more effort is to be put in phrases of power for the sake of testing the supposed system. Great want exists for a machine which consumes much less or ideally no strength whilst acting test. This challenge objectives at evolution of a novel method for evaluating the torque transmitting capability of strength transmission structures without eating more electricity. To begin with all of the subsystems of the proposed design could be recognized and each of them will be designed for getting their dimensions. Then those dimensional models can be transformed to solid version of the assembled configuration the use of three-D CAD software program. Functional load with a purpose to be experienced with the aid of this design may be assessed and structural analysis could be carried out against those loads using Finite Element

Method (FEM) in business FEA software program i.e. ANSYS.

Keywords:Power transmission, Mechanical link, Rotating shafts, FEM, CAD

1. INTRODUCTION

Power transmission machine is generally used to routinely link two or more rotating shafts, most often parallel. These systems can be used as a source of motion, to transmit strength efficiently, or to song relative movement as shown in Fig. 1.



Fig. 1. Typical power transmission system

The second a transmission system is prepared it needs to be qualified before put in ordinary use. This needs to measure and test supposed torque of the transmission structures. Conventional way of dynamic characterization of

power transmission device has got the demerit of energy intake to a extra extent. Because of this more attempt is to be put in phrases of strength for the sake of trying out the supposed system. Great need exists for a machine which consumes less or ideally no strength while performing test. Hence it's far determined to explore the provision of such system.

A model of dry friction tensioner in a belt- pulley device thinking about transverse belt vibration is developed, and have an effect on of the dry friction on the system dynamics is examined. The discretized formulation is divided into a linear subsystem including linear coordinates and an nonlinear subsystem addressing tensioner arm vibration, which reduces the size of the iteration matrices when using the harmonic stability method [1]. A check bench for the assessment of the electricity efficiency of belt drives is presented. The construction and measurement technique is discussed with appreciate to dimension accuracy and reproducibility. Also the impact of additional parameters which include belt anxiety and misalignment can be analyzed[2]. The paper work basically emphasis at the case concerning a belt drive, which is used for flour mill operation. The operation of a flour mill is defined as under. A high capability flour mill demand electricity approximately 27 Hp for crushing the grain into required shape of flour. A bag of grain wheat is poured into the hopper. The wheat grain continuously inserted thru hollow space to the crushing stone. Generally this crushing stone gets electricity through belt drive. Due to crushing motion of the stone the wheat grain then transformed into desired flour [3]. A comprehensive selection of belt type and creation from commercial and agricultural programs is appreciably tested and compared for idling loss and energy transmission performance. Data is documented for Vee, joined-V, V-ribbed, and synchronous belt sorts and for cogged,

plain, and laminated V-belt constructions. The degree of power savings accomplished by the replacement of plain-base wrapped V-belts with cogged V-belts is emphasized[4].

Belt drives are used in numerous applications to transmit strength between numerous device elements. Some not unusual programs encompass transportation vehicles, family appliances such as vacuum cleaners and washing machines, and gadgets pushed by way of electric motors which includes power machine tools. Belt drives come in diverse kinds, together with: at belts, serpentine belt drives, v-belt drives and push belts for continuously variable transmissions [5]. The thesis offers the design and analysis of a Twin Tensioner for a Belt-driven Integrated Starter-generator (B-ISG) system. The B-ISG is an emerging hybrid transmission carefully resembling conventional serpentine beltdrives. Models of the B-ISG system's geometrichomes and dynamic and static states are derived and simulated [6]. Belt drives have been serving the industry for a protracted period. Certain functions of belt drives which include slippage, tension fluctuations, and sliding of the belt on the pulleys result in fairly nonlinear deformation, huge inflexible frame motion, dynamical touch with sticking and slipping zones and cyclic tension. The performance of motion control for belt drives is vital in lots of business fields and is affected by these factors [7]. As it was referred to earlier, all the existing systems are beneficial for measuring tension on my own and no machine is available that can examine the torque transmitting functionality. Further traditional approach of dynamic characterization of strength transmission system has were given the demerit of energy consumption to a more extent. Because of this extra effort is to be placed in terms of power for the sake of testing the meant machine. Great need exists for a machine which consumes

less electricity even as performing check.

This work objectives at evolution of a method for evaluating torque transmitting functionality of electricity transmission structures without eating more energy via adopting novel way.

2. DESIGN PHILOSOPHY

Proposed design will enable the designer to recover part of energy required to test the transmission system. Proposed design with all subsystems is shown in Fig. 2.

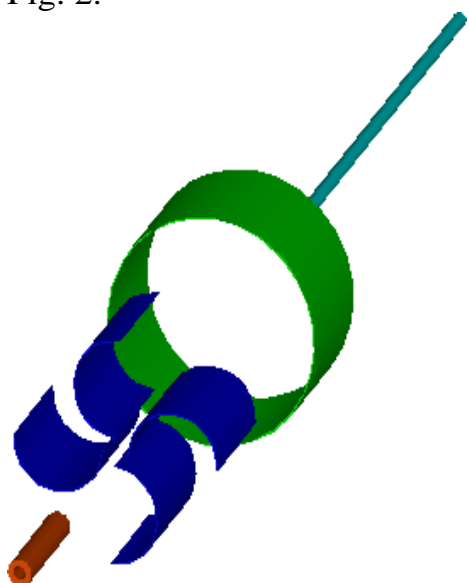

Suspension Element

Hub

Two pulleys which are of various size might be established on commonplace shaft so as to be attached to motor shaft. Other set of pulleys can be hooked up on another commonplace shaft. It is to be noted that as pulleys are of various size, two drives may have differential speed and the identical speed could be conveyed to either side of electro-mechanical snatch. With no electrical excitation to the seize, the input shaft & output shaft freely rotate. With electrical excitation, the enter shaft becomes coupled to the output shaft. Motor feeds the specified torque to drive with a purpose to be fed to magnetic grasp as enter while the weight torque is less than the output torque, the clutch drives without slip. Load torque will be expanded steadily and whilst it crosses output torque, the take hold of will slip

smoothly at the torque stage set through the coil input modern as input torque and load torque values are known, price of load torque at which seize slips might be taken as output torque. This output torque can be as compared with enter torque to assess the torque transmitting ability of the energy transmission system.

From the above figure the following components are identified for which detailed design is carried out.

- Supporting disc
- Shaft
- hub
- suspension element

3. DESIGN SPECIFICATIONS

Following design inputs are considered

- Type of power transmission: Flat drive
- Allowable stress = 100MPa
- Outcome of design is summarized in Table 1.

Table 1: Design parameters

Sl. No.	Design Parameter	Value
Electro-mechanical clutch		
1.	Torque range	6 to 400 N-m
2.	Maximum rpm	1800
Pulley		
1.	Diameter	1.4 m
2.	Width	750 mm
3.	Number of arms	6
Motor		
1.	Torque	400 N-m
2.	Rpm	1800
Shaft		
1.	Diameter	100 mm
2.	Length	5 m
Bearing		
1.	Outer diameter	180 mm
2.	Width	34 mm
3.	Designation	6220-2Z

4. STRUCTURAL ANALYSIS

Structural evaluation of trailer system is carried out the use of Finite Element Method (FEM) in ANSYS software so that it will examine the design adequacy against the self-weight with 1g acceleration. Maximum Von Mises strain thus obtained is in comparison with allowable stress and received to be

had thing of safety.

Static analysis

- Minimum available factor of safety should be more than the desired factor of safety (1.5).

Modal analysis

- System should not have any frequency at 27 Hz and 30 Hz associated with operating speeds of engine i.e. 1607 rpm and 1800 rpm.

To begin with geometric version of the intended layout is built in 3-d CAD software from its dimensions. However load bearing contributors are most effective considered for evaluation. Then geometric version is transformed into FE version by means of discretizing shafts and frame with beam (BEAM4) elements and all other subsystems like pulley, motor, clutch, and many others with mass (MASS21) factors as all subsystems are made from metal its fabric homes are taken into consideration for the analysis Nodes similar to base of the frame restrained for all DOF.

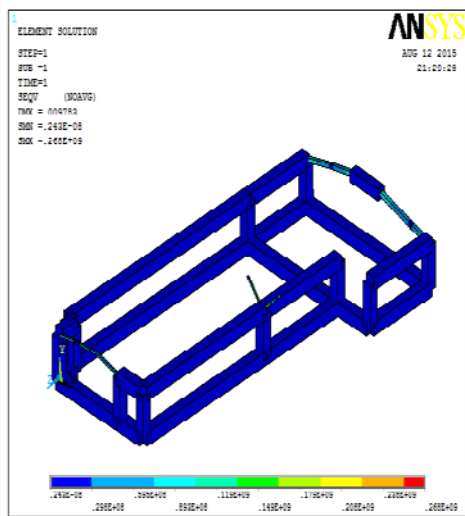
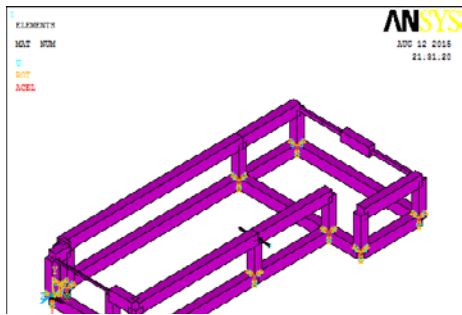

FE model with boundary conditions is

shown in Fig. 3.

Fig. 3:

FEmodel

Static analysis was carried out and the corresponding Von Misses

Fig.4. Stress plot

Then dynamic (Modal) analysis changed into also carried out. Modal analysis is the take a look at of the dynamic properties of structures under vibration excitation. In structural engineering, modal analysis uses a structure's average mass and stiffness to find the diverse durations that it's going to obviously resonate at. A modal analysis calculates the undamped herbal modes of a system. These modes are given in decreasing order of length and are

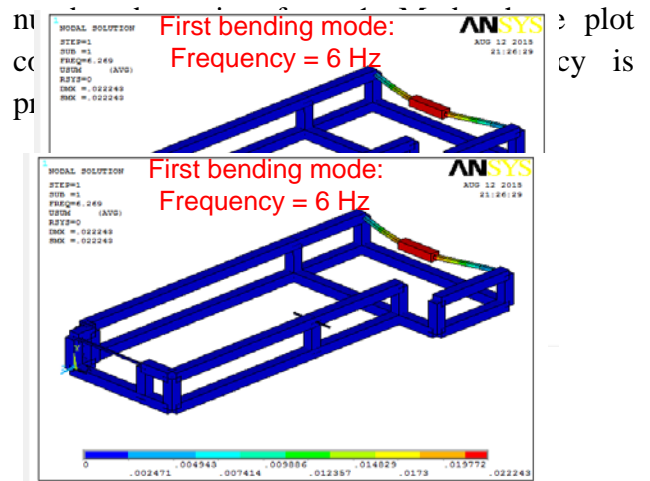

Fig.5. Mode shape

5. CONCLUSION

This work aimed toward evolution of a technique for evaluating torque transmitting functionality of strength transmission systems without consuming greater energy by adopting novel means. Proposed design will allow the designer to recover part of power required to check the transmission device. Available aspect of protection is observed to be (2.46) by comparing the maximum stress with that of allowable pressure (Yield) of metal material i.e. 660 MPa. As the available aspect of protection (2.46) is more than minimum favored issue of protection (1.5) the design is safe. Test gadget does no longer have any frequency at 27 Hz and

30 Hz associated with running speeds of engine
i.e. 1607 rpm and 1800 rpm.

REFERENCES

- [1]. “Energy loss and efficiency of power transmission belts”, The association of energy engineers, Atlanta, Georgia.
- [2]. Shenjin Zhu, “Modeling, System Identification and Control of a Belt Drive System”, MS thesis, 2001.
- [3]. Doorookim, “Dynamic modeling of belt drives using the elastic/perfectly-plastic friction law”, MS thesis, 2009.
- [4]. S. Dereyne, P. Defreyne, E. Algoet and K. Stockman., “Construction of an energy efficiency measuring test bench for belt drives”, Ghent University, campus Kortrijk.
- [5]. Shrikant A. Thote, M.K. Sonpimple and G.D. Mehta., “An Approach to Find the Stresses Induced In a Flat Belt during Half Rotation of a Driving Pulley” International Journal of Innovative Technology and Exploring Engineering, 2013.