



MINE SAFETY SYSTEM USING WIRELESS SENSOR NETWORK

Borhade Ganesh Lahanu¹, Prof. Kadu Mahesh B.²

¹ME (Microwave) Amrutvahini College of Engineering, Sangamner

²(Guide) Professor, Amrutvahini College of Engineering, Sangamner

ABSTRACT

This paper describes the work carried out on the design and construction of a mine safety system prototype using a wireless sensor network with the objective of building a safety system to monitor the ambient characteristics of the mining environment. A review of the current literature relating to the health and safety of mine workers and mine safety systems is done. The subsystems of the prototype system are then simulated. The hardware consisted of electronic circuitry where a microcontroller is the principal processing unit. A graphical user interface is also implemented. A number of qualification tests are carried out. The temperature, humidity, airflow, and noise sensor measurements have an accuracy of 89.01%, 98.55%, 90.5%, and 89.53%, and a resolution of 0.105 °C, 0.12% RH, 0.05 m/s, and 0.23 dB SPL, respectively. In addition, gas and dust sensors met the specification; however, the accuracy could be improved. Two controlled outputs were implemented in the form of ventilation switching and a noise protection scheme.

1 Introduction

An underground mining operation proves to be a risky venture as far as the safety and health of workers are concerned. These risks are due to different techniques used for extracting different minerals. The deeper the mine, the greater is the risk. These safety issues are of grave concern especially in case of coal industries. Thus, safety of workers should always be of major consideration in any form of mining, whether it is coal or any other minerals. Underground coal mining involves a higher risk than open pit mining due to the problems of ventilation and

potential for collapse. However, the utilization of heavy machinery and the methods performed during excavations result into safety risks in all types of mining.

Modern mines often implement several safety procedures, education and training for workers, health and safety standards, which lead to substantial changes and improvements and safety, level both in opencast and underground mining. Coal has always been the primary resource of energy in India, which has significantly contributed to the rapid industrial development of the country. About 70% of the power generation is dependent on it thus, the importance of coal in energy sector is indispensable. But the production brings with it the other byproducts, which proves to be a potential threat to the environment and the people associated with it. In lieu of that the present work is a sincere attempt in analyzing the graveness and designing a real time monitoring system of detection by using the ZigBee technology.

1.1 Background and Motivation

In underground mine, ventilation systems are critical to supply adequate oxygen, keeping up non-dangerous and nonlethal environments and an effective working mine. To monitor an underground mine, can help killing high hazard environments. Primitive procedures of monitoring a mine's air can be followed back to the utilization of canaries and different creatures to ready diggers when the climate gets to be lethal.

The progression of technology has allowed mine monitoring techniques to become more sophisticated, yet explosions in underground coal mines still occur. The safety issues of coal mines have gradually turned into a major concern for the society and nation. The occurrence of

disasters in coal mines is mainly due to the harsh environment and variability of working conditions. So, it makes the implementation of mine monitoring systems essential for the safety purpose. Wired network systems used to be a trend for traditional coal mines, which have really played a significant role in safely production in coal mines. With the continuous enlargement of exploiting areas and depth expansion, laneways have become blind zones, where numerous unseen dangers are hidden out. Moreover, it is not possible there to lay expensive cables, which is also time consuming. So, it is essential to have a wireless sensor network mine monitoring system, which can be disposed in such mines in order to have a safe production within.

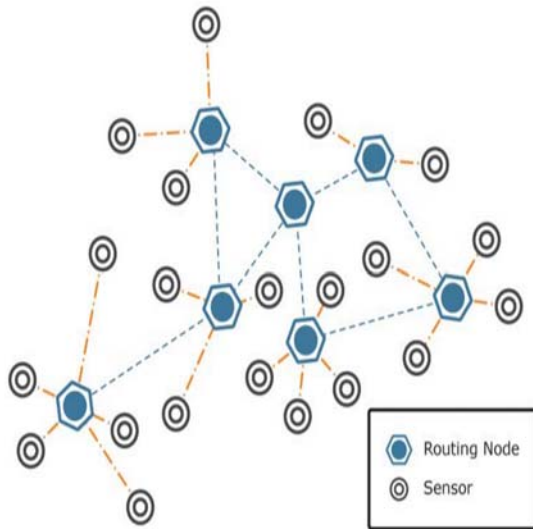

Figure 1.1 Wireless Sensor Network It has three major advantages over wired monitoring network systems:

1. There is no need of cables to lay and easy installation in blind areas, reducing cost of the monitoring system. The number of nodes can be increased to eliminate blind areas. Also, it offers a general communication and allocation of the goal.
2. The dense nodes ensure the data acquisition with high accuracy and optimum data transmission, and further realization of realtime monitoring system for mine environment.
3. A little computing ability, storage capacity with data fusion of sensor nodes make them suitable for the remote monitoring system.

1.2 Objective

Mining environment often has hidden dangers within such as toxic gases, which may present severe health exposures to the people working within mining. These gases need to be detected at times and informed the dangerous situation in right time for the safety of miners. Wired network monitoring systems have assisted the mine safety significantly, but it is not idea for all types of mining environment.

The research investigations to be carried out with the following objectives:

1. Detection of different toxic gases within mining environment
2. Communication establishment between sensors and Zigbee
3. Establishment of Wireless Sensor Network
4. Design of a real-time monitoring system

2 Mine Gases and their Impacts

There is an existence of specific systems or schemes which are put into place for these hazardous environments in order to protect the worker from harm. The higher level term for these systems/schemes is the Occupational Health and Safety.

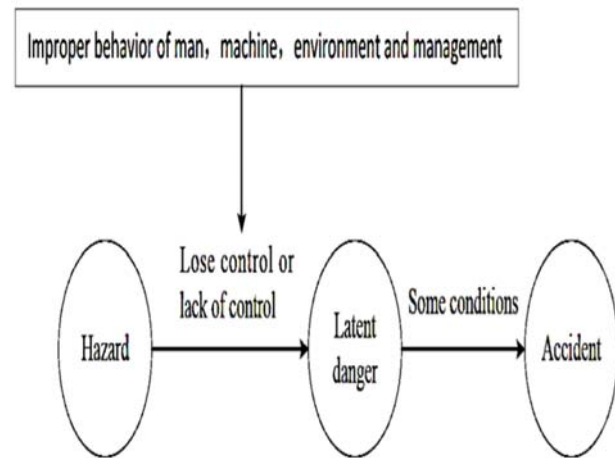

Fig 2.1 -Relationship between a hazard, latent danger and an accident

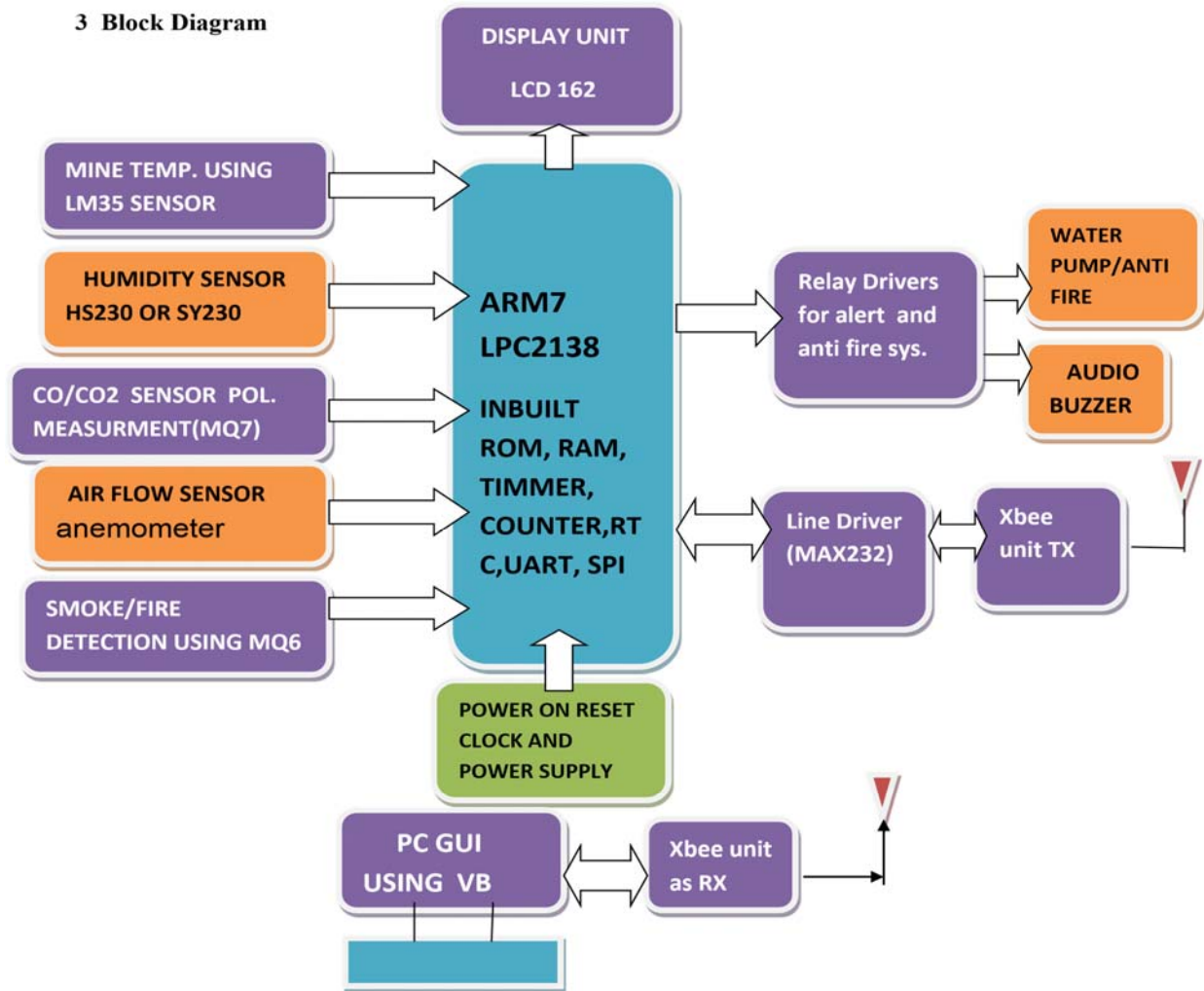

Fig 3.1 Block Diagram

3.2 Hardware Section:

Temperature, humidity, Air flow, C0/CO2, Methane gases sensor.

- Signal conditioner circuit of above parameter.
- ARM7 LPC2138 controller Board. □ LCD 16x2 display,
- Actuator and alert circuit.
- Zibee module interface with ARM7 UART.
- Zibee module interface with PC/Laptop Power Supply.

4 Different parameter to be monitored

4.1 Temperature sensor block

The temperature is sensed by the LM35. The signal conditioning block is inserted to achieve appropriate linear measurement of temperature. Output voltage of temperature block is applied to

ADC1C0 of arm controller for measurement purpose.

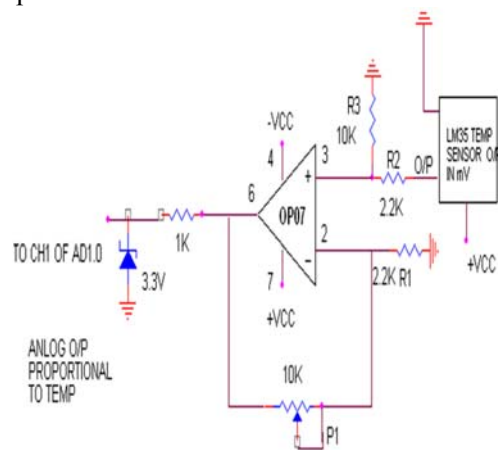
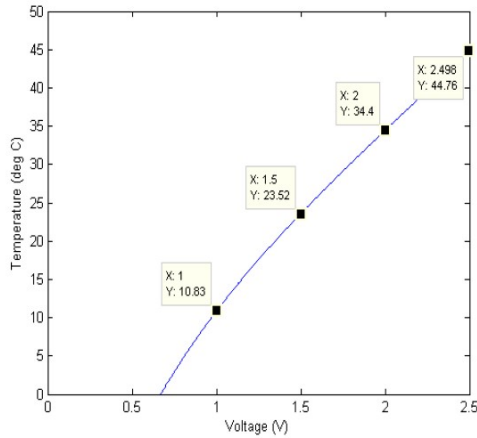

Fig. 4.1 Temperature Sensor



Graph 4.1- Temperature sensor voltage

4.2 Humidity Measurement and signal Conditioning

This is the sensor which is used to measure the ambient humidity inside the mine. This sensor has a typical current draw of 200 μ A [12] which makes it ideal for a battery operated system. This sensor produces a varying voltage depending upon the ambient water vapour exposed to the sensor. The output voltage produced from the sensor has a range of 0.8V _ 3.8V.

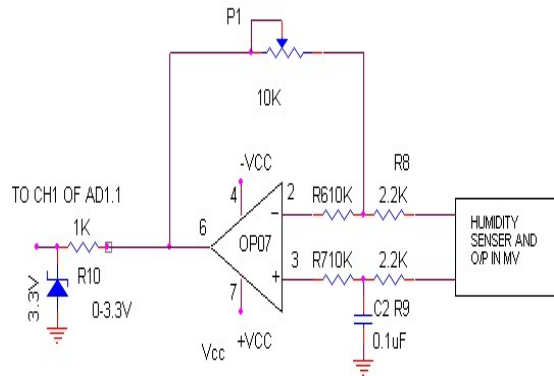

Fig 4.2 Humidity Measurement and signal Conditioning

4.3 Measurement of CO :(MQ-7 OR MQ135)

Measurement of gas pollutants in atmosphere is always a challenging job due to the accuracy required in its measurement. Among the various gas sensors available in the market semiconductor sensors are considered to have fast response, high stability, low cost, long life, low dependency on humidity, low power consumption, and compact size etc. The correlation between the sensor resistance and the concentration of the CO gas in ppm (C) is expressed by the following equation.

$R_S = R_0 (1 + K\sqrt{C})$, (1) where R_s is the electrical resistance of the sensor;
 R_0 is the electrical resistance of the sensor at zero ppm;
 K is the constant for the particular sensor;
 C is the gas concentration in ppm.

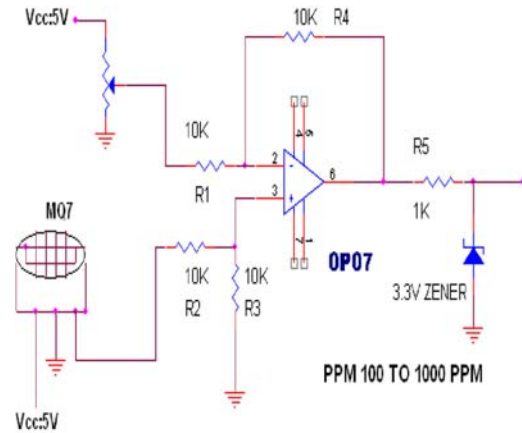

Fig 4.3 Measurement of CO

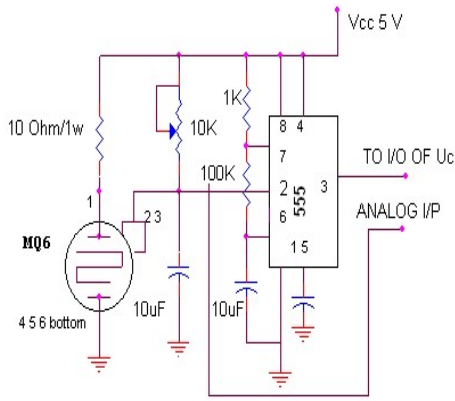

Fig4.3.1 MQ-7 sensor, MQ7 Module

4.4 MQ-6 Methane/Combustible Gas

Sensitive material of MQ-9 gas sensor is SnO₂, which with lower conductivity in clean air. It make detection by method of cycle high and low temperature, and detect CO when low temperature (heated by 1.5V). **Character Configuration**

- * Good sensitivity to CO/Combustible gas
- * High sensitivity to Methane, Propane and CO



4.4 MFig 4.4 MQ-6 Methane/Combustible Gas Q-6 Methane/Combustible

Sources of CH4

Methane in mine is mainly released from five sources:

1. To recover methane in advance of mining from gob or goaf wells.
2. From ventilation air in underground mines (dilute concentrations of methane).
3. From an abandoned or closed mines, from which methane may leak out through the vent holes or through fissures or crevices in the earth.
4. Extremely flammable methane (CH4) or firedamp, as it is brought in numerous coalfields, and due to the profundities and weights, it gets to be imbedded in the coal. As unearthing are made, methane gas is freed into the air.
5. Fugitive emissions from post-mining operations, in which coal keeps on give off methane as it is stacked away in pores and transported.

4.5 AIR FLOW SENSOR:

This is the sensor which is used to measure the ambient air_ow inside the mine. This sensor was built from principles utilizing a slotted optical switch in conjunction with a 3 cup anemometer. This functional unit will therefore be discussed in two parts, one part for the design and implementation of the electronic component and another for the design and implementation of the mechanical cup anemometer. A slotted optical switch is a component which consists of an LED and a phototransistor.

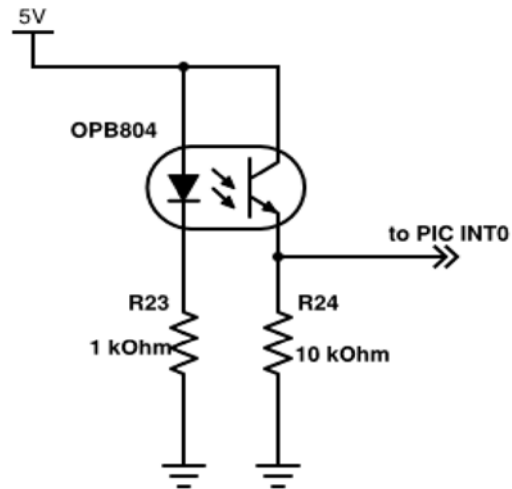
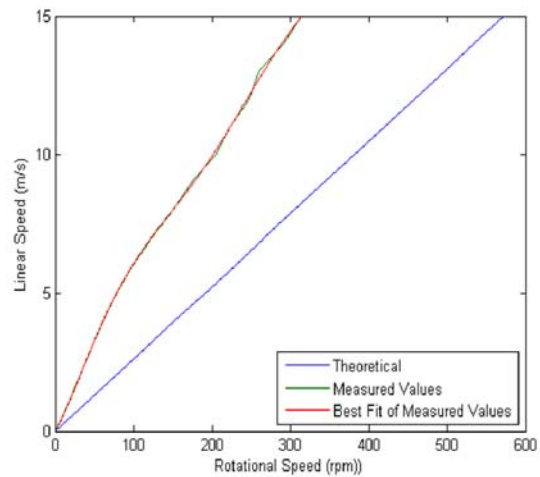

Fig 4.5 Airflow Sensor



Graph 4.5- Airflow sensor Response

5 System Design

5.1 System Hardware Design

This monitoring system contains several components like boards (Arduino board, Xbee module and Zigbee USB interfacing board), LCD (Liquid crystal display), different sensors and other small electronic components. This chapter gives a detailed review of each of this part along with its working principle.

5.2 Alert and actuator driver

This section consists of two relay driver section with full isolation using opto coupler. One relay is used to activate siren system while in danger and another is used to provide water pump on/off control in case of fire or smoke detection.

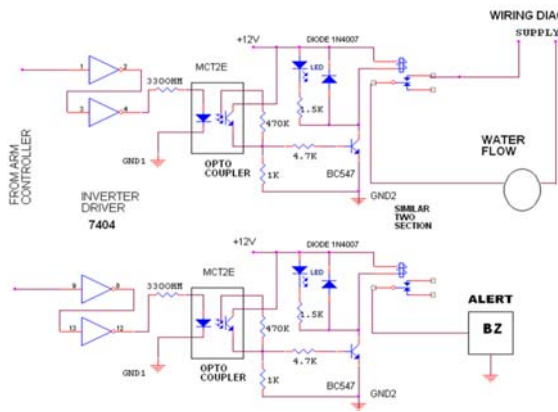
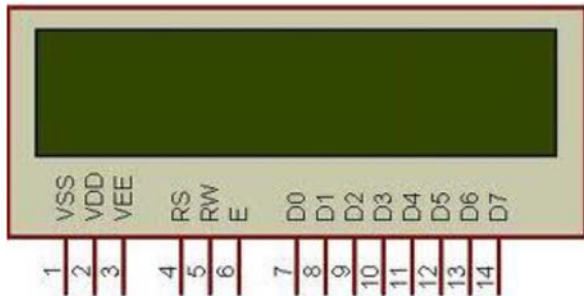

Fig 5.2 -Relay Driver section With Isolation

5.3 LCD DISPLAY

It is used as output device. On LCD display we can show different parameter and present status. 16x2 LCD module Interfacing



5.3 LCD DISPLAY MODULE

5.4 Zigbee:

The Xbee Pro S2B module is a wireless sensor network, which operates within the Zigbee protocol and support the unique need of low cost and low power. This module requires minimum power and provides reliable delivery of data between devices. It operates at 2.4GHz frequency band.

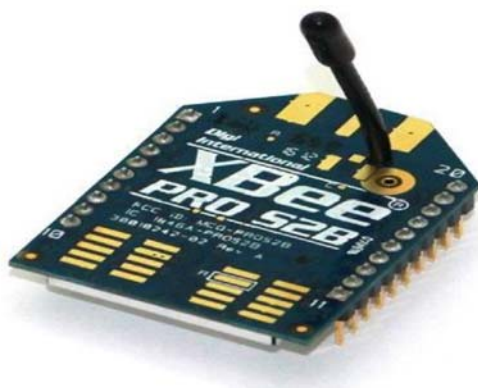

Fig 5.4 Xbee Module

Features :-

- 3.3 to 3.6 V Supply voltage
- ISM 2.4 GHz Operating frequency

- Outdoor RF line-of-sight range is up to 1 km with appropriate high gain antennas and elevation
- RF data rate is 250 Kbps
- Serial Interface data rate are 1200, 2400, 4800, 9600, 19200, 38400, 57600, 115200
- Antenna Options are MMCX Connector, Chip Antenna, and Wire Antenna
- Supported network topologies are Point-to- point, Point-to -multipoint & Peer-to – peer

Number of Channels 16 Direct Sequence Channels.

5.5 Zigbee USB Interfacing Board

ZigBee (Xbee) USB Interfacing Board is used to interface Xbee wireless module with computer systems. This Board is used to connect ZigBee modules to make communication between PC to PC or laptop, PC to Mechanical Assembly or robot, PC to embedded and microcontroller based Circuits. As ZigBee communicates through Serial Communication so 25 other end of USB which is connected to a PC, treated as COM port for Serial Communication. It is provided with indication LEDs for ease.



Fig 5.5 Zigbee USB interfacing Board

5.6 UART

Zigbee unit is interfaced with ARM7 controller with the help of max 232. Only Txd and Rxd lines are used to interface both the unit.

6 Advantages Disadvantages and further modification

6.1 Advantages

1. Sensors used have high sensitivity and are easy to handle.
2. Low cost system, providing maximum automation.

3. Closed loop design prevents any chances of disturbing the environment.
4. Low maintenance and low power consumption.
5. Can be used for different plant species by making minor changes in the ambient environmental parameters.
7. Provides a user-friendly interface hence will have a greater acceptance by the technologically unskilled workers.
8. Facility to remotely monitor the mine status using wireless communication is implemented.

6.2 Disadvantages

1. Complete automation in terms of pest and insect detection and eradication cannot be achieved.
2. No self-test system to detect malfunction of sensors.
3. Requires uninterrupted power supply.
4. To increase the communication distance add off networking is required.

6.3 FUTURE WORK-

A major risk that can cause a large amount of damage in the mine environment is fire. An additional subsystem that could be considered for addition to the mine safety system is fire suppression. This would include the use of a smoke sensor and a controllable fire retardant system.

While the wireless communication implemented in this design shows success with urban/indoor communication, in order to enhance the system even further, multiple identical sensor nodes could be introduced. This would turn the master/slave (2 node star) topology into a mesh network. By using the proprietary technology from the manufacturer of the XBee module known as DigiMesh a smart mesh network can be configured. This would allow for a sensor node to be out of range with the collection node, but as long as that sensor node can communicate to another sensor node, the data can be passed along from the end sensor node to the collection node through intermediary sensor nodes. This would increase the communication range inside the mine.

7 CONCLUSION

Therefore a complete mine safety system was constructed such that the system is compact and modular, using a combination of mechanical hardware, electronic hardware and specific software. This system can measure ambient characteristics inside the mine environment and

communicate them between two nodes using the ZigBee communication protocol. The temperature, humidity, airflow and noise sensor measurements have an accuracy of 89.01%,98.55%,90.5%, 89.53% and a resolution of 0.105_C, 0.12% RH, 0.05m/s and 0.23 dB SPL respectively.

8 References

- 1 *Occupational Health and Safety ISO 45001*, Int. Org. Standardization, UK, 2016.
- 2 X. Chen and P. Yu, ``Research on hierarchical mobile wireless sensor network architecture with mobile sensor nodes," in Proc. Int. Conf. Biomed. Eng. Informat., Oct. 2010, pp. 2863_2867.
- 3 P. Deshpande and M. S. Madankar, ``Techniques improving throughput of wireless sensor network: A survey," in Proc. Int. Conf. Circuit, Power Comput. Technol., Mar. 2015, pp. 1_5.
- 4 S. Kasera, N. Narang, and S. Narang, ``Network topology and extent in Communication Networks: Principles and Practice". New York, NY, USA: McGraw-Hill, 2005.
- 5 Y.-S. Choi, Y.-J. Jeon, and S.-H. Park, ``A study on sensor nodes attestation protocol in a wireless sensor network," in Proc. Int. Conf. Adv. Commun. Technol., Feb. 2010, pp. 574_579.
- 6 Y. K. Tan and K. Tseng, ``Low-voltage, DC grid-powered LED lighting system with smart ambient sensor control for energy conservation in green building," in *Smart Grid Infrastructure & Networking*. New York, NY, USA: McGraw-Hill, 2013.
- 7 L. Yan-Fang *et al.*, ``Fiber laser methane sensor and its application in coal mine safety," *Procedia Eng.*, vol. 26, pp. 1200_1204, Sep. 2011.
- 8 J. Dickens and R. Teleka, ``Mine safety sensors: Test results in a simulated test stope," in Proc. 6th Robot. Mechatronics Conf., Oct. 2013. pp. 105_110.
- 9 W. Bing, X. Zhengdong, Z. Yao, and Y. Zhenjiang, ``Study on coal mine safety management system based on hazard, latent danger and emergency responses," *Procedia Eng.*, vol. 84, pp. 172_177, Nov. 2014.