



## RCET MCU DEVELOPMENT BOARD

Amal Moideen M<sup>1</sup>, Suhas P.S<sup>2</sup>, Anupama E<sup>3</sup>, Aparna P.K<sup>4</sup>, Fasil V.G<sup>5</sup>, Gokul M.Narayanan<sup>6</sup>  
Electronics and Communication Engineering Department, Royal College of Engineering and  
Technology, Akkikavu., Kerala, India

### Abstract

The embedded electronics system and design is a fast growing field in which tremendous improvements are happening day by day. The main problem is the lack of skilled persons. One of the factor that leads to this situation is that most of the persons dealing with this field are having theoretical idea more than that of practical skills. So as a solution we are introducing a new learning and doing method. This idea motivates beginners as well as professionals to study and practically implement ideas related with this field. The main platform is ATMEGA32U4 which is an advanced and reliable version of AVR microcontroller family. The RCET MCU development board using AVR's ATMEGA32U4 is developed in order to provide basic hardware and programming skills in embedded electronics field. The board features various interfaces available on-board using ATMEGA32U4 controller. The aim of this development board is to help the students and beginners to explore the capabilities of microcontrollers and practice application development for various interfaces with minimal hardware configuration. The board has been developed with many applications which includes keypad interface, LCD interface, motor etc.

**Keywords:** ATMEGA32U4, UART, RISC, ISP.

### I. INTRODUCTION

The proposed development board provides seven interfacing circuits in a single board and thus helps even beginners to works. There is no large circuitry and very minimal size as we are using double sided PCB instead of single sided.

The hardware coding and software testing is done using EAGLE, because of the preferred minimal size and the schematic can be designed by connecting various components for the circuitry through ports in different sheets. Moreover, EAGLE can save different layout files which are accepted by several PCB fabrication companies. This development board has better analog design and it has built in USB capability. The hardware implementation of this product is done using PCB<sup>[2]</sup> ATMEGA32U4<sup>[3]</sup> development board is made from double sided PCB board to provide extra strength to the connector joints for increased reliability. Board can work on 5V DC supply. It has built-in reverse polarity protection. 7805 voltage regulator has heat sink for heat dissipation so that it can supply 1 Amp. Current continuously without getting over heated. It has switches for boot loading, reset and power. It also has RS232 interface with DB9 female connector based on MAX232. Open pads for connecting microcontroller pins to external devices are also provided. ATMEGA32U4 Development Board is made from double sided PTH PCB board to provide extra strength to the connector joints for increased reliability. Board can work on 5V DC supply. It has built-in reverse polarity protection. 7805 voltage regulator has heat sink for heat dissipation so that it can supply 1Amp current continuously without getting over heated. It has switches for boot loading, reset and power. It also has RS232 interface with DB9 female connector based on MAX232.

The microcontrollers are powerful tools for transmission controlling. ATMEGA32U4 is a low-power 8 bit microcontroller based on AVR enhanced RISC architecture. The AVR core combines an instruction set with general purpose working registers and connected to ALU.

Therefore, the resulting architecture is more efficient in terms of code. The compatibility between chips is good.

II. SYSTEM MODEL

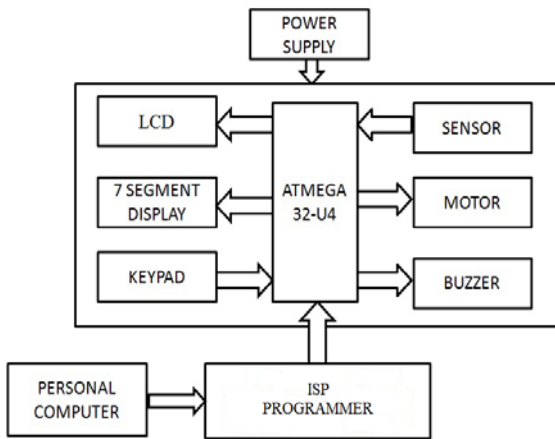

Fig. 1. Block Diagram

USBASP Programmer<sup>[6]</sup> is used as the interface between computer and the development board. AVR USBASP is a USB in-circuit programmer which is used to program most of the Atmel AVR controllers. It consists of an ATmega8, passive components such as resistors, capacitors, LEDs etc. The programmer uses a USB driver and it have an advantage that ,there is no need of a special USB controller. By using AVR USBASP it just needs one step to finish the process of connecting the AVR USBASP with computer and with microcontroller and simply program it. AVR USBASP

works under many platforms like Linux, Mac OS X and Windows .The programming speed is up to 5kBytes/sec.

Its SCK option is supported to the targets with low clock speed of less than 1.5Mhz. Burning circuit includes USB and RS232 interfaces. Here , the user can decide either USB or RS232 is used for programming . The required program can be uploaded into the circuit via personal computer. A microcontroller programmer or microcontroller burner is a hardware device accompanied with software which is used to transfer the machine language code to the microcontroller /EEPROM from the PC. The compiler converts the code written in languages like C<sup>[1]</sup>, java etc to machine language code and stores it in a hex file. A microcontroller programmer acts as an interface between the PC and the target controller.

III. PROTOTYPE DESIGN

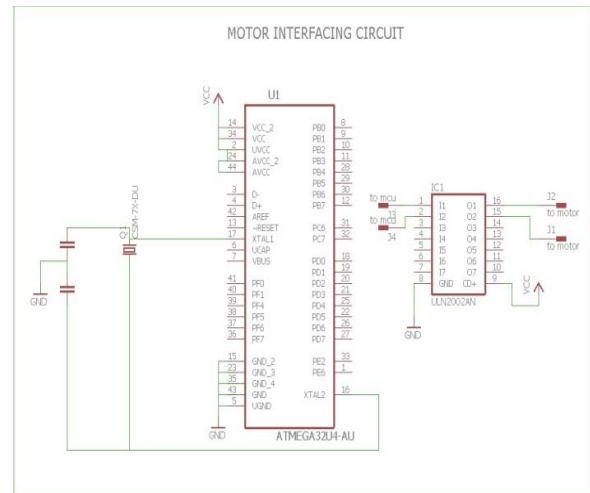

Fig.2. DC Motor Interface

A direct current, or DC, motor is the most common type of motor. DC motors normally have just two leads, one positive and one negative. If you connect these two leads directly to a battery, the motor will rotate. If you switch the leads, the motor will rotate in the opposite direction.

To control the direction of the spin of DC motor, without changing the way that the leads are connected, you can use a circuit called an H-Bridge. An H bridge is an electronic circuit that can drive the motor in both directions. H-bridges are used in many different applications, one of the most common being to control motors in robots. It is called an H-bridge because it uses four transistors connected in such a way that the schematic diagram looks like an "H."

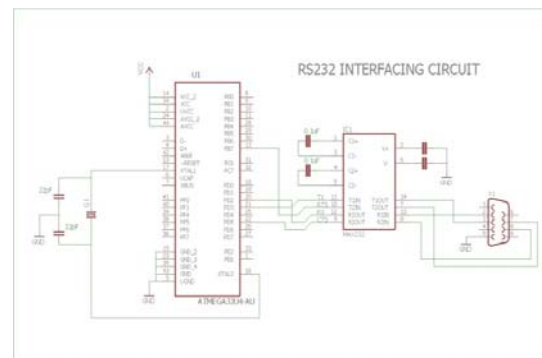

Fig.3. RS232 Interface

PCs are equipped with 2 serial ports and 1 parallel port. These 2 types of ports are used for communicating with external devices are working with different ways. The 8 separate

wires in parallel port are used for the transmission and reception of 8 bit data. This helps for rapid transferring of data but the cable required is more bulky because, it must contain more number of individual wires. In serial port, transmission and reception of 1 bit data are done at a time over 1 wire. So it takes 8 times of the time that needed for the transmission of each byte of data.

RS232 is a standard for serial communication of data transmission. It formally defines the signals connecting between a DTE (data terminal equipment) such as a computer terminal, and a DCE (data circuit-terminating equipment or data communication equipment), such as a modem. The RS-232 standard is commonly used in computer serial ports. The standard defines the electrical characteristics and timing of signals, the meaning of signals, and the physical size and pinout of connectors. The current version of the standard is TIA-232-F Interface Between Data Terminal Equipment and Data Circuit-Terminating Equipment Employing Serial Binary Data Interchange, issued in 1997.

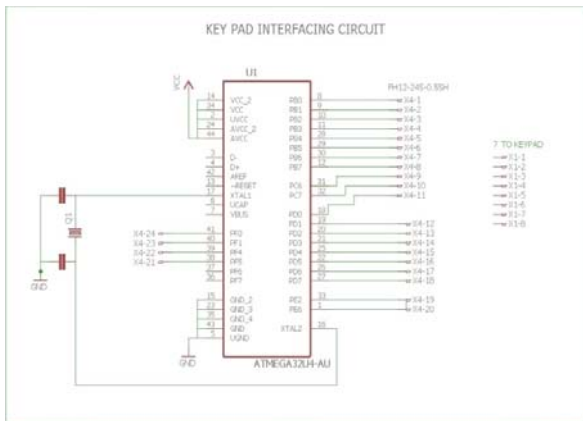

Fig.4. Keypad Interface

The proposed system also includes interfaces like seven segment display<sup>[4],[5]</sup>, LCD display and buzzer.

Digital displays are the link between digital world of ones and zeros, and numeric of the human world. The parallel combinations of ones and zeros can represent different number systems such as binary, hexadecimal, digital numbers etc. Digital displays in most of the simple instruments, use the numbers 0-9 and are represented by seven segmented displays. Each segment of the seven segment display is controlled by a single bit, And combinations of segments turned ON or OFF is used to display all the numbers 0-9 and a few characters, such as A,

B,C,D, E, and F. Seven-segment displays are made with LED's and they are arranged in a pattern which represents the number '8' .

IV. THE PROGRAMMING

In the RCET MCU development board we can make use of IDE like ATMEL studio and sketch studio for programming. The process of uploading the boot-loader to the flash memory is done using ISP device. Uploading the boot-loaders can help the microcontroller to work with sketch and ATMEL studio.

All AVR microcontrollers has a small memory space in it. That memory is the area where the program is stored. When the chip starts up it starts running whatever program is in the flash. So all we have to do is figure out how to write program in to this memory space. AVR has a set of pins that are the programming pins, you just have to connect the programmer to those pins in the right order when you are ready to program it. Unfortunately, nearly every chip has a different pin-out so its imperative that you look in the datasheet for the correct pins.

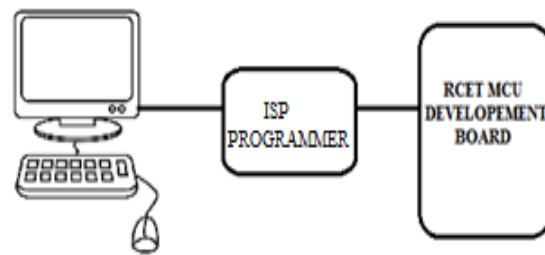

Fig.5. Process of Coding

V. CONCLUSION

RCET MCU development board reduces the complexity of MCU programming for the beginners. It avoids the risk of large number of interconnections for interfacing the output devices and provides basic programs along with all possible output devices. Passion towards embedded field can be increased by this board<sup>1</sup>. The example of interrupt routines have been implemented in C language and the combination of assembly, C source code in a single application as well<sup>[1]</sup>. During the courses, students implement applications with switches, LEDs, LCD display, A/D converter, analog comparator, external interrupt, timer/counter, and UART communication between AVR and

PC. It is very simple to handle other internal interrupts from the peripherals of AVR microcontrollers. For instance, one of the most important application is a serial communication, e.g. the way of transmitting control or measured data between the microcontroller and any external device or a PC computer. For student's individual projects, it is useful to present and also the communication protocols like I2C or USB. In C language this task is simplified. An assembly language program is composed of a series of statements that are either instructions or pseudo-instructions, also called directives. The importance of using flag and RISC architecture is also included.

Skudai, Johor, Malaysia 9-6483,  
www.researchinventy.com\_\_\_\_\_“Cytron  
USBASP Programmer AVR USBASP User's  
Manual, V1.0”, October 2011.

#### REFERENCES

- 1) T.Fryza, Brno University of Technology, *"Basic C Code implementations for AVR microcontrollers"*, 14th International Workshop on Systems, Signals and Image Process-ing, 2007 and 6th EURASIP Conference focused on Speech and Image Processing, Multi-media Communications and Services.
- 2) Shaikh Noor Farooque, Ansari Mohammed Faizan, Javed Shaikh, Pragati Pal, *"Automated Pcb Drilling Machine With Ecient Path Planning"*, International Journal of Advanced Research in Computer and Communication Engineering, Vol. 4, Issue 4, April 2015.
- 3) Rev.: Atmel-7766I-USB-ATmega16U4-32U4-Datasheet\_07/2015 © 2015 Atmel Corporation 1600 Technologies.
- 4) Abdulrahman A.A. Emhemed, *"Implementation 7 Segment Display by Educational Board - Software /Hardware Interfacing"*, International Journal of Engineering Research and Applications (IJERA) ISSN: 2248-9622 www.ijera.com Vol. 2, Issue 3, May-Jun 2012.
- 5) Ezekwe Chinwe Genevra, Okwu Patrick Ikechukwu, Mbonu ekene Samuel, Ude Nnaemeka Godwill, *"An Effective Approach to Designing Seven Segment Static Display, Systems with Complete Character Representation"*, Research Inventy: International Journal Of Engineering And Science Vol.3, Issue 12 (December 2013), PP 45-49 Issn (e): 2278-4721, Issn (p): 231
- 6) Cytron Technologies Sdn. Bhd. 19, Jalan Kebudayaan 1A, Taman Universiti, 81300