



PERFORMANCE ANALYSIS ON LTE BASED TRANSCEIVER DESIGN WITH DIFFERENT MODULATION SCHEMES

Delson T R¹, Iven Jose²

¹Research Scholar, ECE Department,

²Professor, ECE Department Christ University, Bangalore, India

Abstract

This research paper aim on developing wireless communication transceiver designs based on the Long term evolution (LTE) architecture initiated by 3GPP consortium. Initially, performance comparison on Bit error rate (BER) and Signal to noise ratio (SNR) both in fading (Rayleigh channel) and non-fading (AWGN) channels are evaluated for a single transmitter and receiver system design. Different modulations schemes are used such as Binary Phase Shift Keying (BPSK), Quadrature Phase Sift Keying (QPSK), and Quadrature Amplitude Modulation (QAM) are used. Later, the transceiver designs incorporate Orthogonal Frequency Division Multiplexing (OFDM) with suitable LTE modulation formats specifications [8]. Performance evaluation of BER and SNR are analyzed on designed transceiver structures. This paper further evaluates the capacity or throughput of the channel using Shannon capacity equation for a band limited AWGN channel with an average transmit power constraint [7]. The capacity of the channel is analyzed using parameters such as bandwidth and transmitting power as constraints. These parameters define the bounds on communication system.

Index Terms: LTE, Transceiver, Rayleigh, QAM, OFDM, SNR, BER, Capacity.

I. INTRODUCTION

Wireless communication standards in GSM and GPRS available in 2G cellular standards offers appreciable voice quality but offers poor data or internet services. The 3GPP Long Term Evolution (LTE) represents a major advancement in 3G cellular generation and beyond. With the advent of revolutionary market

for increased data rate with an improved Quality of Service (QoS) such as less transmission power, low noise level, improved bandwidth and minimum spectral congestion and others designing a transceiver system posed a great challenge. Performance evaluation on channel parameters such as BER and SNR, capacity or throughput, bandwidth, power level, noise level acceptance and others are also factors considered while designing user equipment and a base station forming a transceiver system pair. 4G standard used LTE architecture release 8 in which MIMO is combined with OFDM modulation using 16 or 64-QAM format [9]. Later release of LTE such as 12 and beyond forms the basis for developing the architecture for 5 G communication standards. One of the 5G technologies is Massive MIMO architecture where a very large number of antennas are placed in base stations [1]. This improves data rate of 100 times and other parameters pertaining to the QoS. LTE higher releases shows the necessity of OFDM and MIMO combination in the architecture that can significantly improve the data rate about 1 Gbps in 100 Mhz channel bandwidth, optimum cell coverage with improved spectral efficiency and backward compatibility of LTE standards with earlier wireless communication generations [9]. High demand of data rate and throughput made the wireless cellular communication standards to incorporate multiple transmitting antennas at user equipment and multiple receiver antennas at base station referred as MIMO technology.

This paper focused on designing transceiver system based on LTE architecture which is the main component of 5 G standard. The transceiver design simulation commences from single transmitter and receiver structure for basic modulation schemes such as BPSK, QPSK,

M-QAM in Rayleigh stochastic fading channel and AWGN non fading channel. Later designs include the transceiver structure using OFDM which is the core of LTE architecture [9]. Mathematical analyses of the designs are developed in this paper. Matlab is used as simulation environment for the transceiver design. Performance comparison of the parameters such as BER and SNR of the system is evaluated for different transceiver design structure. Shannon capacity equation for AWGN channel is simulated and the average power and bandwidth are taken as constraints in estimating the capacity or throughput of the communication system..

II. LTE ARCHITECTURE AND KEY FEATURES

LTE architecture is defined by 3GPP in 4G Cellular standard. This architecture supports high speed data transfer in mobile phones and data terminals. Initially, LTE release version 8 is released and later to LTE-Advanced, release 10 that serves well features for 4G cellular standard [4]. The comparison chart of LTE release 8 and 10 are provided in Table 1. The goals of LTE will ensure 3GPP’s standard over cellular technologies. Some of the important parameters improvement of LTE focused on significantly increased data rate, improving spectral efficiency, lowering cost, ensuring QoS, making use of new spectrum opportunities such as millimeter wave spectrum, integration with other standards, backward compatibility to earlier mobile generation standards like GSM, GPRS and others. LTE newer releases 12 and beyond are the architectural design for 5 G standard [4], [10].

Table:1 Comparison of parameters –LTE Vs LTE-A [4]

Technology	LTE	LTE-A
Peak Data rate Down Link(DL)	150 mbps	1 Gbps
Peak Data rate Up Link(UL)	75 Mbps	500 Mbps
Transmission bandwidth (DL)	20 MHz	100 MHz

Mobility	Optimized for low speeds (<15 Km/Hr) High performance at speeds up to 120Km/Hr Maintain Links at speeds up to 350 Km/Hr	Same as that in LTE
Coverage	Full performance up to 5 Km,	(a) Same as that in LTE (b) Should be optimized or deployment in local areas/micro cell environments. That is, reasonable performance up to 30 Km and acceptable performance up to 100 Km
Scalable bandwidths	1.3,35,10 AND 20 MHz	Upto 20 – 100 MHz
Capacity	200 active users per cell in 5 MHz	3 times higher than that in LTE

The key features of LTE includes support to MIMO technology, multiple access scheme between user terminal and base station such as OFDMA for downlink channels an SC-FDMA for uplink channels, adaptive modulation and coding schemes such as DL modulations support QPSK, 16-QAM AND 64-QAM and UL modulations support QPSK and 16-QAM.

LTE network architecture consists of two main sections such as Evolved Universal terrestrial radio access network (E-UTRAN) and Evolved Packet Core (EPC) [8]. EPC consists of mobility

management entity (MME), serving gateway (S-GW), packet data network gateway (P-GW), home subscriber server (HSS) and PCRF. E-UTRAN consists of eNodeB (eNB) which connects User Equipment (UE) with EPC. Here x2, s1, s2, Sgi etc denotes the interface between different network component such as eNB, MME, S-GW, P-GW etc. Existing system such as WCDMA, GSM, GPRS are connected to the LTE through serving GPRS support node (SGSN) [8]. The network architecture of LTE is shown in Fig 1.

LTE architecture support for OFDM scheme using modulation formats – QPSK, 16 QAM and 64 QAM in multipath fading channel. LTE 16-QAM modulation with

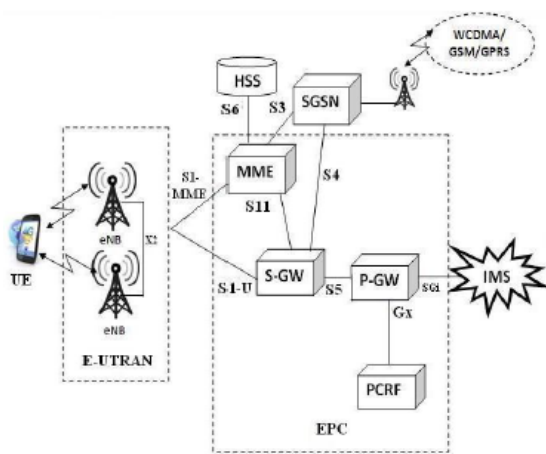

Fig 1. LTE Network Architecture [8]

OFDM in downlink and SC-FDMA with uplink are the multiple access methods used. Stochastic random channel is referred to as Rayleigh channel model which is an example of multipath channel model where there is no direct line of sight between transmitter and receiver but multiple delay lines or taps between transmitter and receiver through various reflector materials over the air interface channel. First part of the research paper provides mathematical analysis on BER equations on modulation formats for both AWGN and Rayleigh channel. Second section describes the physical and block diagram understanding of OFDM scheme. It discuss about the Shannon’s equation for channel capacity by selecting average transmitting power as constraint.

III. MATHEMATICAL ANALYSIS ON TRNSCEIVER DESIGN

This section explains mathematical analysis of the transceiver designs. As in LTE architecture,

the multiple access schemes between UE and eNodeB (base station) is through OFDM scheme which includes different modulation formats. Also, this research analysis concentrates on two performance parameters evaluation such as BER and Capacity of the channel. These parameters are linked to SNR and transmission power. In this section, BER equation for an AWGN channel and Rayleigh model channel are explained and followed by OFDM scheme. The block diagram of basic wire line and wireless communication model are shown. The benefits of orthogonal sub bands of OFDM which enhances the throughput of the communication system. The block diagram of OFDM transceiver structure is also provided.

A) BER equation on BPSK modulation with AWGN and Rayleigh model

The model in Fig 2 corresponds to wire line communication model where, noise n is AWGN. The received symbol y, is given by

$$y = x + n \tag{1}$$

Noise N is Gaussian in nature, therefore probability density function

$$f_N(n) = \frac{1}{\sqrt{2\pi\sigma^2}} e^{-\frac{n^2}{2\sigma^2}} \tag{2}$$

Gaussian noise with mean = 0, variance = σ^2 . Probability of error equation for BPSK modulation

$$P_e = P(n \geq \sqrt{E_b}) = \int_{\sqrt{E_b}}^{\infty} f_N(n) dn = \int_{\sqrt{E_b}}^{\infty} \frac{1}{\sqrt{2\pi\sigma^2}} e^{-\frac{n^2}{2\sigma^2}} dn \tag{3}$$

put $\frac{n}{\sigma} = t$ then $dn = \sigma dt$

$$P_e = \int_{\frac{\sqrt{E_b}}{\sigma}}^{\infty} \frac{1}{\sqrt{2\pi}} e^{-\frac{t^2}{2}} dt \tag{4}$$

Where, $\sqrt{E_b}$ is the transmitted symbol can take 0 or 1 bit corresponding to BPSK.

$$P_e = P(N(0,1) \geq \sqrt{\frac{E_b}{\sigma^2}}) = Q(\sqrt{\frac{E_b}{\sigma^2}}) = Q(\sqrt{SNR}) \tag{5}$$

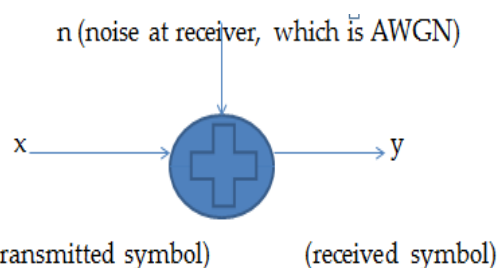

Fig 2. AWGN Channel communication model

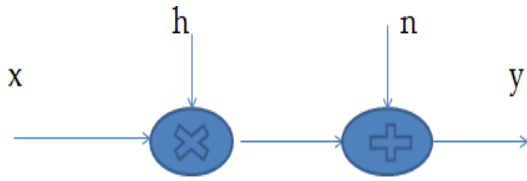

Fig 3. Wireless channel communication model

Wireless communication channel received signal, $y = hx + n$

Where, x -: transmitted symbol, h -: fading channel coefficient, n -: white Gaussian noise, y -: received symbol.

Here, h corresponds to impulse response due to Rayleigh channel which is a multipath propagation model. BER calculated for BPSK modulation scheme over Rayleigh channel is given by the expression

$$BER = Q\left(\sqrt{2SNR}\right) = Q\left(\sqrt{2\alpha^2 SNR}\right) \quad (6)$$

Average bit rate can be determined by averaging with respect to the distribution of random channel coefficient amplitude,

i.e, is $f_A(\alpha) = 2\alpha e^{-\alpha^2}$

Average BER for BPSK modulation in a Rayleigh fading channel =

$$\int_0^\infty Q\left(\sqrt{2\alpha^2 SNR}\right) 2\alpha e^{-\alpha^2} d\alpha = \frac{1}{2} \left(1 - \frac{1}{\sqrt{1+SNR}}\right) \quad (7)$$

B) OFDM Scheme

OFDM is a key wireless broadband technology employed in LTE standard. Compared to GSM system bandwidth of 200 kHz, OFDM system used in wireless system where large bandwidth say around 20 MHz in 4G or 5G cellular standard. It also used in other wireless standard such as WiMAX. It can generate 500 Mbps or even 1 Gbps data rate availability for the transceiver system. IEEE 802.11 a, g, n, ac Wireless LAN standards employs OFDM scheme of data transfer.

OFDM is the technique employed in wireless transceiver system to overcome Inter Symbol Interference (ISI) issue. ISI can occur if delay spread is much lesser than symbol time. Symbol time is inversely proportional to bandwidth and if a single carrier system is used symbol time can significantly decrease and thereby cause ISI. The basic principle of OFDM is to divide the single broadband channel to multiple channels employs different carriers equally spaced. Doing this

technique, the bandwidth required for each carrier modulating the signal will have less bandwidth and thereby increases the symbol duration. The entire channel bandwidth say B is divided into equally spaced N carriers or sub bands forming a bandwidth of B/N . As the carriers of sub bands forms integral multiple of harmonics, each sub band is orthogonal to its neighboring sub bands. Hence, the frequency division is orthogonal and multiplexing, say N carriers taking signal coefficients from transmitter to the channel. Hence, the technique referred to as orthogonal frequency division multiplexing. OFDM employs a detailed transmitter and receiver sections. The block diagram of transceiver system employs OFDM is shown in Fig 4. The structure shows the blocks of transmitter structure and receiver structure includes IFFT-FFT pair and cyclic prefixes which are the two main ingredients of OFDM transceiver design. QAM- Modulation format is used in OFDM for both uplink and downlink structure in LTE based transceiver design.

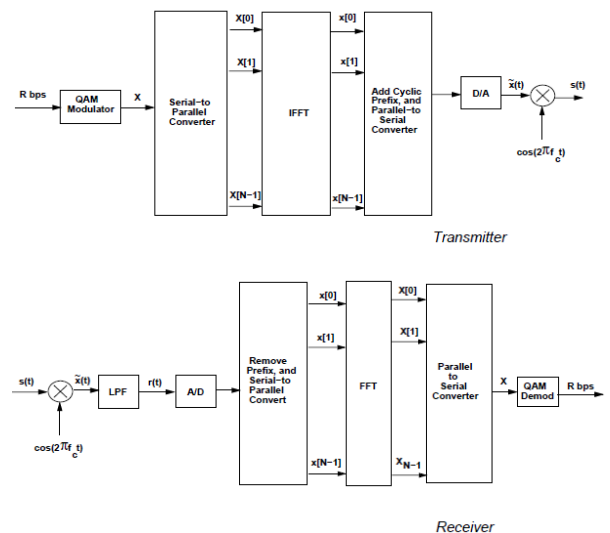

Fig 4. OFDM Transmitter and Receiver section [2]

Information bits are passed through OFDM structure, where bits can used modulation formats – QPSK, 16-QAM, 64-QAM as in LTE standard. The bits are mapped in the corresponding symbols according to the modulation format. These serial modulated bits are transferred parallel to the IFFT structure where the symbols which are in the frequency components converted to time samples [2]. The IFFT yields the OFDM symbols consisting the

transmitted sequence $x[n]$ of length, say N with the equation

$$x[n] = \frac{1}{\sqrt{N}} \sum_{k=0}^{N-1} X[k] e^{j2\pi kn/N}, \quad 0 \leq n \leq N-1 \quad (8)$$

Cyclic Prefix are added to OFDM symbol passing through parallel to serial converter and the digital bits are converter to analog by D/A converter resulting in the baseband OFDM signal which is then frequency up converted and transmitted over the air interface medium. At the receiver side, reverse operation takes place to extract demodulated signal. In this section FFT structure is used to convert to frequency domain samples also matched filtering is used by coherent demodulation process. The frequency symbols mapped in the constellation diagram of particular modulation format are passed through the demodulation process to get the information bits extracted at the receiver side. The principle of OFDM is the Multi carrier modulation process. Instead of single carrier system, in OFDM, N symbols are transmitted across N Sub carrier for a total symbol time. This effectively increases the data rate of the channel, total throughput of the system. In this research paper, simulations on the transceiver design are done on OFDM BPSK, QPSK, M-QAM modulation formats trough Rayleigh fading channel.

C) Shannon’s capacity expression on transceiver design

Wireless transceiver design demands for determining maximum amount of data transfer according to the condition of the channel. Shannon’s theory shows that maximum data transfer through the wireless channel is possible depending on the capacity of the channel. Throughput or capacity of the channel depends onto constraints such as transmission power and bandwidth. In fact the theorem suggests boundary for the maximum transmission rate or capacity of the wireless channel. The expression of Shannon’s theorem for capacity of band limited AWGN channel with an average transmit power as constraint is given by

$$C = B \log_2 \left(1 + \frac{P_s}{N_0 B} \right) \text{ bits/sec} \quad (9)$$

Where, C -: capacity in bits/sec, B -: bandwidth in Hz, P_s is the signal power and N_0 is the noise spectral density.

IV. SIMULATION RESULTS

Transceiver designs are simulated in Matlab environment. The simulation results depict BER Vs. SNR plotted between different modulation schemes under Rayleigh fading channel. Further, QPSK, 16-QAM, 64-QAM in evaluation of BER. OFDM scheme under different modulation schemes are plotted that is the integral part of LTE. Capacity of channel using Shannon’s expression taking bandwidth and transmission power as constraints is also analyzed. The results show that BER increases for higher order modulation formats. But, to improve the data rate with acceptable BER, a tradeoff between the modulation schemes need to take care while designing the transceiver design.

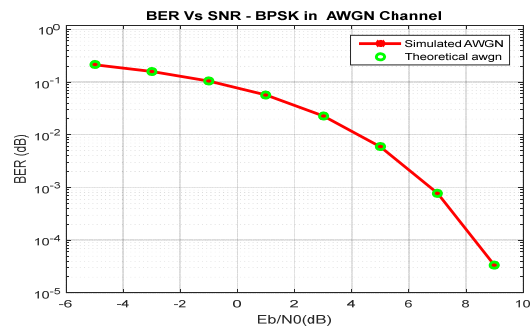

Fig 5. BER Vs SNR BPSK over AWGN Channel

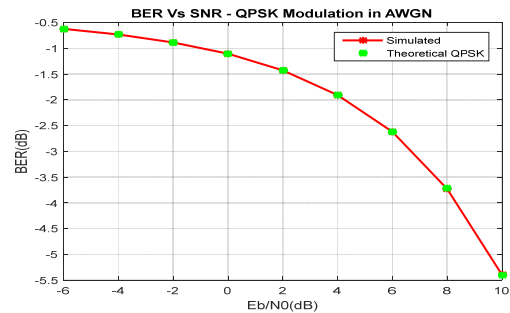

Fig 6. BER Vs SNR QPSK over AWGN Channel

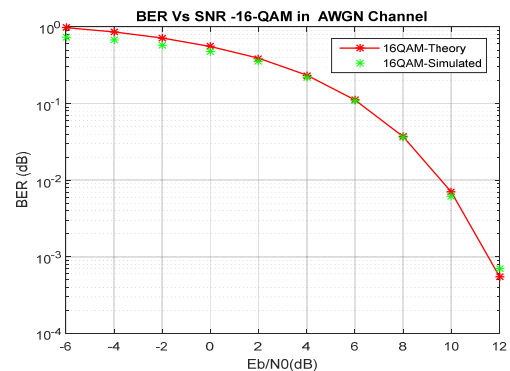

Fig 7. BER Vs SNR – 16-QAM over AWGN Channel

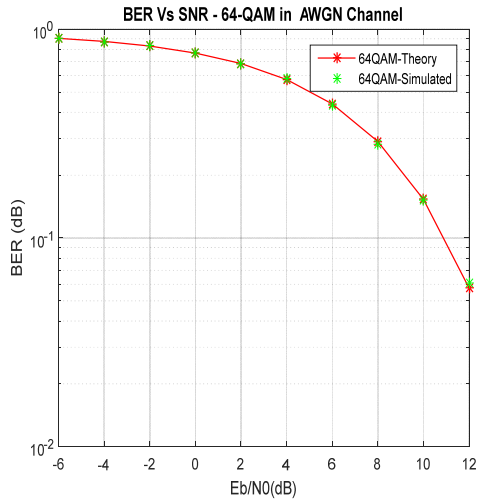

Fig 8. BER Vs SNR – 64 QAM over AWGN Channel

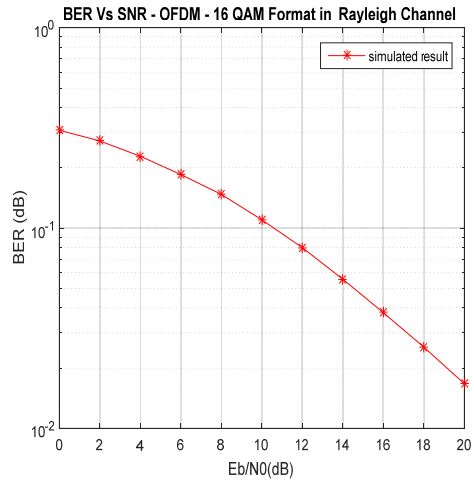

Fig 11. BER Vs SNR – OFDM - 16-QAM modulation scheme over Rayleigh channel

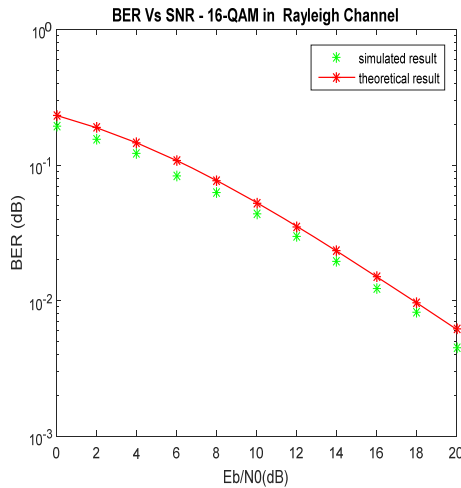

Fig 9. BER Vs SNR- 16-QAM over Rayleigh channel

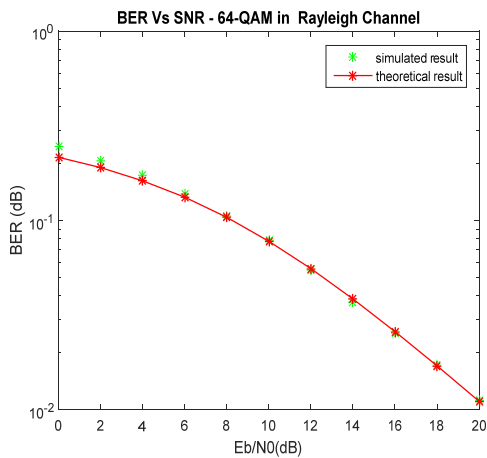

Fig 10. BER Vs SNR- 64-QAM over Rayleigh channel

The parameter BER and SNR performance evaluation analyzed through simulation are provided in Table 2.

Table 2. Simulated parameters BER vs. SNR

SL NO	Modulation	Channel	Number of bits	SNR (dB)	BER (dB)
1	BPSK	AWGN	1000000	6	0.002
2	QPSK	AWGN	1000000	6	0.002
3	16-QAM	AWGN	10000	6	0.1
4	64-QAM	AWGN	10000	6	0.4
5	16-QAM	RAYLEIGH	10000	6	0.09
6	64-QAM	RAYLEIGH	10000	6	0.15
7	OFDM 16-QAM	RAYLEIGH	10000	6	0.11

Second part of the simulation results depicts the capacity of the channel through Shannon’s equation to determine capacity or throughputs of the transceiver design under AWGN channel [7]. Two simulations are used for capacity estimation that shows transmission power can be the major constraint rather than bandwidth. The simulated results show that capacity increases with transmission power but not with bandwidth after a limit.

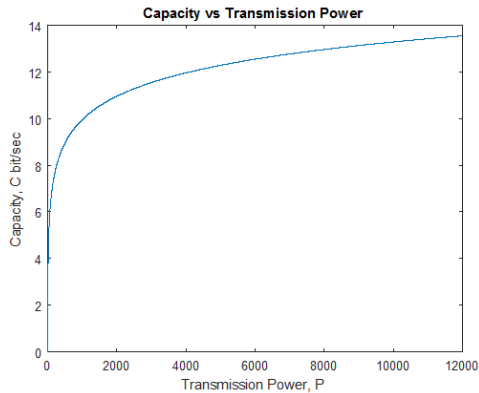

Fig 12. Capacity Vs transmission Power

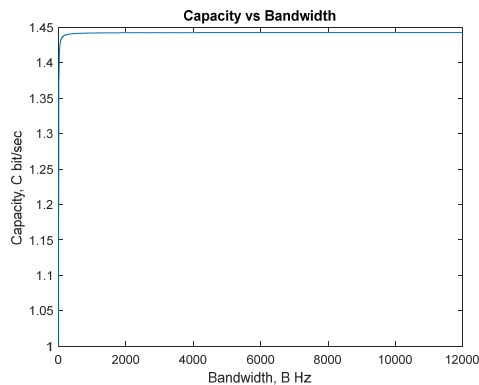

Fig 13. Capacity Vs Bandwidth

V. DISCUSSION OF RESULTS

The simulation results for the transceiver design are categorized into two parameters evaluation such as BER vs. SNR and Capacity or Throughput of the channel. BER vs. SNR for different modulation in Table 2 shows that for a constant SNR of 6dB, BER is maximum in 64 QAM and least in BPSK. This proves theoretical aspect of modulation schemes. For higher order modulation schemes, with available signal power, more number of bits are mapped and tried to send to the receiver to improve data rate parameter of the channel. Hence, BER will increase for higher order modulation format. But, data rate is a main concern and there should be use of higher order modulation schemes to be used with acceptable BER values. These simulated results are compared with the work of two published technical papers in the same area of study. The first paper is the work done by M Raju and M Ashoka Reddy[8], where Evaluation of BER Vs. SNR over Rayleigh channel in M-QAM modulation format in OFDM scheme. The simulated results of 16-QAM in this article is in par with the simulation result obtained. However in the second paper which is the work

done by Reena Parihar and R Nakeeran [9] on the area of analysis of 16 QAM in fading channel, the technology of MIMO also came into the design perspective. The authors incorporated MIMO technique which is the inclusion of more number of antennas at transmitter and receiver stations, thereby increasing data rate. Here, simulation plot of BER vs. SNR for antenna configuration 4 x 4 for 16-QAM OFDM, BER obtained is 0.2 which is large value than the results obtained in this paper.

VI. CONCLUSION AND FUTURE WORK

This research paper focus on LTE architecture which is the key concept in 4G and 5 G cellular standard developed by 3GPP consortium. A detailed benefits and features of LTE provided in the article. Further, simulation designs of transceiver designs based on different modulation schemes are developed and a comparative analysis on performance parameters of the system in the context of SNR and BER are implemented. In simulation results listed in Table 2 reflects different BER values for same SNR value 6db for the simulation of transceiver designs for different modulation schemes under fading and non-fading channels. OFDM which is the key feature of LTE with 16-QAM modulation scheme under Rayleigh channel provides higher bit rate but ensures higher data rate for the transceiver design. Also, the simulation graphs depicts the variation of capacity of the transceiver system by taking signal power, bandwidth and bit to noise ratio as constraints. The future work of this research work can develop different MIMO configuration and analyze the performance evaluation of BER, SNR, channel capacity and other parameters of wireless transceiver system.

VII. REFERENCES

- [1]Boccardi, Federico, et al. "Five disruptive technology directions for 5G", IEEE Communications Magazine, Vol. 52, pp. 74-80, 2014.
- [2]Goldsmith, Andrea. "Wireless communications", Cambridge university press, 2005.
- [3]Kamath, H, et al. "Transmit receive chain in LTE", IEEE Annual Ubiquitous Computing, Electronics & Mobile Communication Conference (UEMCON), IEEE, pp. 1-7, 2016.

- [4]Kumar, KN Shantha, et al. "LTE-advanced: future of mobile broadband", TATA Consultancy Services, White paper, pp. 1380-1408, 2009.
- [5]Lu, Lu, et al. "An overview of massive MIMO: Benefits and challenges", IEEE Journal of Selected Topics in Signal Processing, Vol.8, pp. 742-7588, 2014.
- [6] M. F. L. Abdullah, A. Z. Yonis, "Impact of Modulation Techniques on Aggregated LTE Advanced", Proceeding of the 2013 IEEE International Conference on Space Science and Communication (Icon Space), 1-3 July 2013, pp.267-271.
- [7]Proakis, John G., et al. Communication systems engineering. Vol.2. New Jersey: Prentice Hall, 1994.
- [8]Raju, M., and K. Ashoka Reddy. "Evaluation of BER for AWGN, Rayleigh fading channels under M-QAM modulation scheme." IEEE International Conference Electrical, Electronics, and Optimization Techniques (ICEEOT),2016.
- [9]Parihar, Reena, and R. Nakkeeran. "Performance analysis of LTE networks in different transmission modes using 16-QAM under fading channels." IEEE International Conference on Communications and Signal Processing (ICCSP), 2015.
- [10]Sayantan Acharya, Pulak Kabiraj and Debashis De, "Comparative Analysis of Different Modulation Techniques of LTE Network", Third International Conference on Computer, Communication, Control and Information Technology (C3IT), IEEE, pp. 1-6, 2015.
- [11]Terré, Michel, Mylène Pischella, and Emmanuelle Vivier, "OFDM and LTE." Wireless Telecommunication Systems, pp. 95-127, 2013.
- [12]Yun Ye, Dalei Wu, Zhihui Shu, Yi Qian, "Overview of LTE Spectrum Sharing Technologies", IEEE Access, Vol.4, pp. 8105-8115, Nov 2016.