



ANALYSIS OF POWER QUALITY IMPROVEMENT OF BLDC MOTOR DRIVE USING CUK CONVERTER OPERATING IN DISCONTINUOUS CONDUCTION MODE

Bhushan P. Mokal¹, Dr. K. Vadirajacharya²

^{1,2}Department of Electrical Engineering, Dr. B.A.T.U. Lonere, Raigad, M.S

Abstract

Brushless DC motors are found to be useful in a wide area of application and up to certain power level they can almost replace any other motor application under usual environmental conditions. Although they have many advantages over other motors, the conventional methods used to control a BLDC motor produces many power quality issues. This paper presents a simulation based power quality analysis of a Brushless DC drive which uses non-isolated Cuk converter operating in discontinuous conduction mode as a power factor correction. The speed of the motor is controlled by controlling the dc link voltage of VSI using cuk converter prior to the VSI. With the introduction of cuk converter in between bridge rectifier and VSI, it is found that the power quality has been improved with a considerable amount and the power quality indices are within acceptable limits of IEC 61000-3-2. Simulation of this drive configuration is been done in MATLAB Simulink environment.

Index Terms: Brushless DC Motor, Cuk Converter, DC-DC Converter, State-Space Averaging (SSA), Power Quality.

I. INTRODUCTION

Brushless DC motors are becoming more and more popular owing to their many advantages such as high flux density per unit volume, low maintenance requirement, high efficiency, low electromagnetic interference problem, wide speed range control and high ruggedness [1], [2]. Many of these advantages are due to elimination of brushes used for mechanical commutation. As no brushes are present in Brushless DC motor, electronic commutation is done in which

according to rotor position the switches in VSI are commutated.

With such numerous advantages this motor can easily outrun widely used induction motor but up to a certain power level. This is because a brushless DC motor has three phase winding on stator and permanent magnet in rotor used for excitation and beyond a certain power level the weight and cost of permanent magnet becomes excessive and induction motors are found more viable for application [8]. Therefore a brushless DC motors are very much suitable for low and medium power application.

A brushless DC motor drive is operated with a VSI fed with a diode bridge rectifier and a high value capacitor. The speed of the motor is controlled by controlling the duty ratio of high frequency pulse width modulation signals given to VSI [8]. Due to the high value capacitor used in intermediate stage the input supply current is very much distorted resulting in high THD and hence low power factor. The THD of supply is found to be around 65% and power factor around 0.8 which is very low [9]. For a low power application, these power quality indices does not comply and are not permitted according to international power quality standards IEC 61000-3-2.

To come over these problems various techniques are implemented but are not suitable for low power applications due to their drawbacks. As when duty ratios of high frequency PWM given to VSI are controlled the losses in switches are high as losses in switches are proportional to square of switching frequency. Also Direct Torque Controlled (DTC) technique applied for such drive requires greater number of switches and high end signal

processor; here it is worth mentioning the complexity of this technique. Even it might seem that a bridgeless configuration would be a better option, it is not because it is accompanied by high cost of active and passive components.

A DC-DC converter is used in this proposed configuration. DC-DC converters are power electronics circuit which can be considered as DC equivalent of an AC transformer. They provide voltage at a different level than their input voltage. They have excellent energy conversion properties and are theoretically lossless. They are widely used in motor control and regulated power supplies application [8]. There are various topologies of DC-DC converters and have different properties and application area.

One of the type of DC to DC converter is Cuk converter. A Cuk converter can provide output voltage with magnitude higher than, equal to or lower than the input voltage with reversed polarity as of its input. It is derived from the combination of two basic DC-DC converter topologies namely, buck and boost converter. Unlike other DC-DC converter topologies, in Cuk converter a capacitor serves the purpose of energy transfer element from input to output stage. A Cuk converter has many advantages such as full transformer utilization, smooth input and output current, wide conversion ratio, and capacitive energy transfer [5]. For the closed loop operation the modeling of cuk[11] is required for obtaining the proper controller values.

In this paper, the proposed arrangement is found very much effective specifically for low power application. Instead of using a high value dc-link capacitor or controlling the duty ratio of PWM signals given to VSI for speed control, the Cuk converter is used prior to VSI for controlling the dc-link voltage. This arrangement not only provides speed control of BLDC motor in a simpler manner but also the inherent property of a chopper implies power factor correction at ac mains. Although a continuous conduction mode is found reliable, it requires more number of sensor arrangements. Therefore a cuk converter is operated in discontinuous conduction mode as it can provide PFC with a single voltage sensor. The use of single voltage sensor is enough for PFC due to its property 'input current shaping'

[6], which is exhibited only in discontinuous conduction mode. The control technique thus implemented is voltage follower approach.

The operation of cuk converter whether in continuous conduction mode or discontinuous conduction mode is decided by the design parameters. Even the operation of cuk converter in discontinuous conduction mode provides the luxury of using voltage follower approach; it comes at a price of high voltage stresses. This will be studied in this paper.

This paper is organized as follows. The system configuration explaining the conventional and proposed topology is outlined in Section II. The control strategy of BLDC motor drive is explained in Section III. Further, the detailed simulated performance and results are illustrated in Section IV. Finally the conclusion is given in Section V.

II. SYSTEM CONFIGURATION

A. Conventional Topology

Figure 1 shows the block diagram of a conventional Brushless motor drive topology. The diode bridge rectifier is used to convert ac to dc supply and is given to the voltage source inverter (VSI). The filter used in this topology is a high value capacitor.

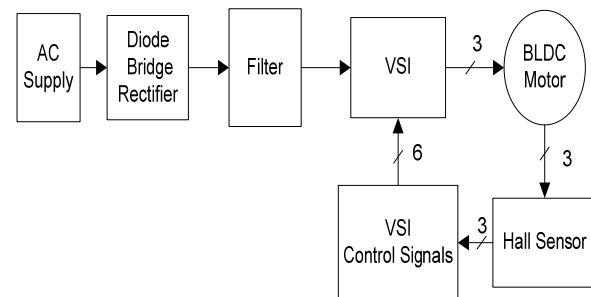

Fig. 1. Conventional BLDC Drive Scheme

The VSI control signals are generated using the Hall Effect sensor signals [2]. The hall sensor senses the rotor position and accordingly the VSI signals are derived. This is given in Table I [8]. This process is known as electronic commutation.

The speed of the drive is controlled by controlling the duty ratio of high frequency pulse width modulation (PWM) signals.

TABLE I
VSI Switch Signals Derived From Hall Effect Sensors

Hall Signals			VSI Switch Signals					
H _a	H _b	H _c	S ₁	S ₂	S ₃	S ₄	S ₅	S ₆
0	0	0	0	0	0	0	0	0
0	0	1	0	0	0	1	1	0
0	1	0	0	1	1	0	0	0
0	1	1	0	1	0	0	1	0
1	0	0	1	0	0	0	0	1
1	0	1	1	0	0	1	0	0
1	1	0	0	0	1	0	0	1
1	1	1	0	0	0	0	0	0

B. Proposed Topology

Figure 2 shows the block diagram of a proposed Brushless motor drive topology.

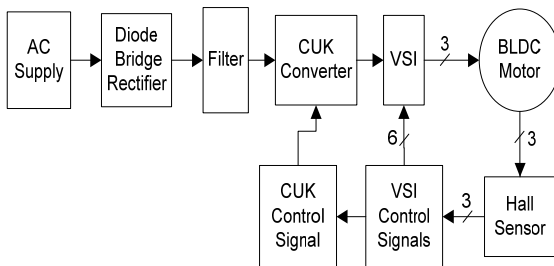

Fig. 2. Proposed BLDC Drive Scheme

With the rest arrangement identical to conventional system, a cuk converter is added prior to VSI. The filter capacitor size is reduced. The MOSFET is used in cuk converter for high frequency operation while IGBTs are used in VSI for low frequency operation. Again electronic commutation happens here but at the fundamental frequency switching mode. By this the switching losses in VSI are reduced. The circuit arrangement is shown in figure 3.

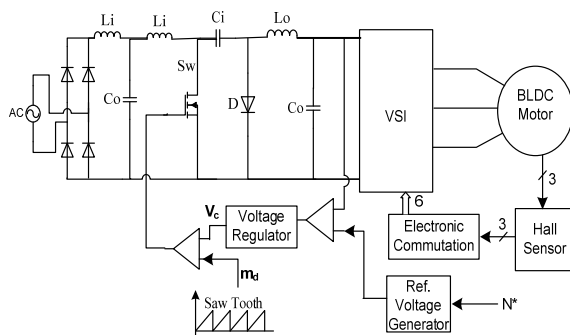

Fig. 3. Circuit Configuration of Proposed BLDC Drive

The approach depicted in figure 3 is voltage follower approach which requires operating the cuk converter in discontinuous conduction mode [7]. In discontinuous conduction mode the current in output inductor (L_o) is discontinuous in switching period. The cuk converter is designed such that it operates in discontinuous output inductor current mode.

III. CONTROL OF BLDC MOTOR DRIVE

The control scheme is divided into different parts for simplification purpose [3].

A. Reference Voltage Generator

The reference voltage (V_{dc}^*) is generated by the reference voltage generator by multiplying the reference speed (N^*) with the voltage constant (k_b).

$$V_{dc}^* = k_b N^*$$

The reference voltage thus generated is then compared with the sensed dc link voltage at the cuk converter output and voltage error signal is obtained which is further given to the controller.

B. Speed Controller

The voltage error signal is given to the controller which is a PI type controller to generate a controlled output for the PWM generation. At any time instant k, the voltage error signal $V_e(k)$ and the controller output $V_c(k)$ is given by,

$$V_e(k) = V_{dc}^*(k) - V_{dc}(k)$$

$$V_c(k) = V_c(k - 1) + k_p[V_e(k) - V_e(k - 1)] + k_i V_e(k)$$

Where k_p and k_i are proportional and integral gain of PI controller.

C. PWM Generator

By comparing the controller output (V_c) of the controller with a high frequency saw-tooth waveform (m_d), a fixed frequency variable duty ratio PWM signal is generated. Conditions are as,

$$m_d(t) < V_c(t) \text{ then } S_w = 1, \text{ else } S_w = 0$$

Where S_w is the cuk converter switch i.e. MOSFET and, 1 and 0 indicates ON and OFF condition respectively.

IV. SIMULATED PERFORMANCE AND RESULTS

The proposed motor drive is simulated in MATLAB Simulink Environment. The Simulation is done as shown in figure 4. The performance of the drive will be evaluated with relation to cuk and with the help of indices such as speed, electromagnetic torque, cuk output voltage, voltage and current across the switch, current in the input and output inductors, voltage across the intermediate capacitor, and motor stator current.

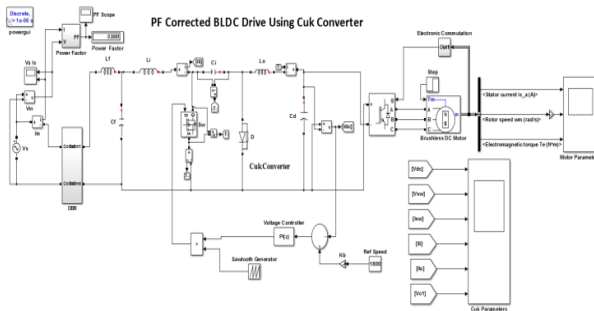

Fig. 4. MATLAB Simulation of Proposed BLDC Drive

The Figure 5 shows the BLDC Steady State motor performance in terms of speed (N), stator current (I_s) and electromagnetic torque (T_e).

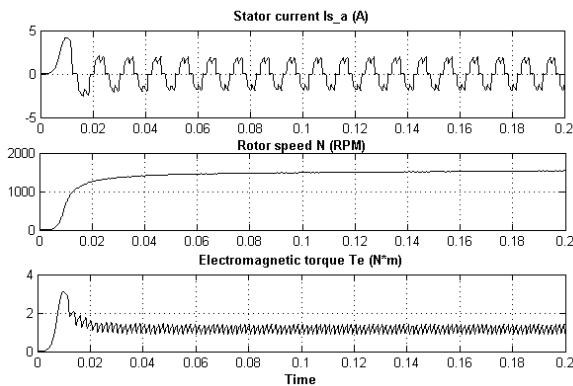

Fig. 5. Steady State Performance of Proposed BLDC Drive

The Figure 6 shows the BLDC motor performance during its starting i.e. in transient state in terms of speed (N), stator current (I_s) and electromagnetic torque (T_e).

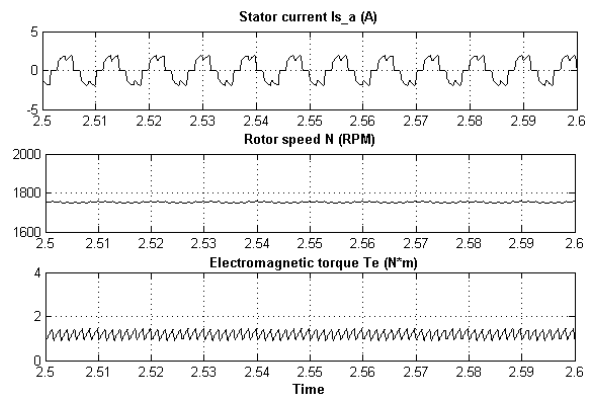

Fig. 6. Transient State Performance of Proposed BLDC Drive

The Figure 7 shows the current and voltage stresses on cuk converter switch (MOSFET). As said before due the operation of converter in discontinuous output inductor current conduction state the current and vottage stresses on switch are more.

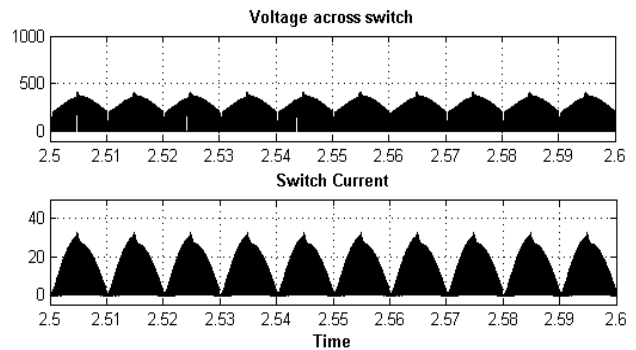

Fig. 7. Current and Voltage stresses on MOSFET

The Figure 8 and figure 9(a),9(b) shows the performance indices of Cuk converter.

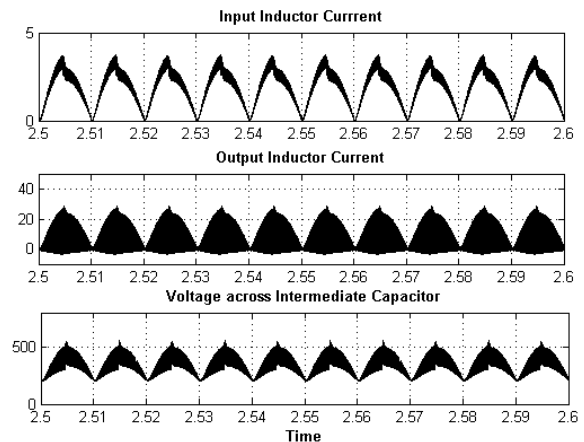

Fig. 8. Current and voltage in Cuk Converter

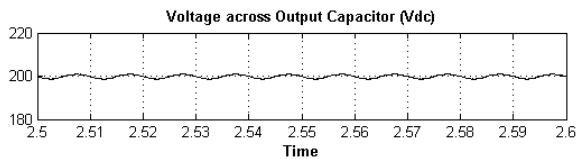

Fig. 9(a). Steady State Output of Cuk Converter

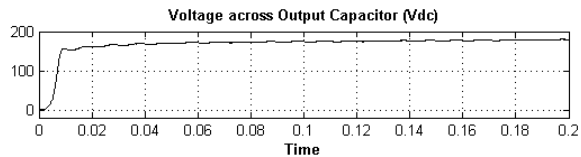

Fig. 9(b). Transient State Output of Cuk Converter

The THD(%) was found to be 5.88% and the power factor was 9.9981 which is almost unity, THD can be seen in figure 10.

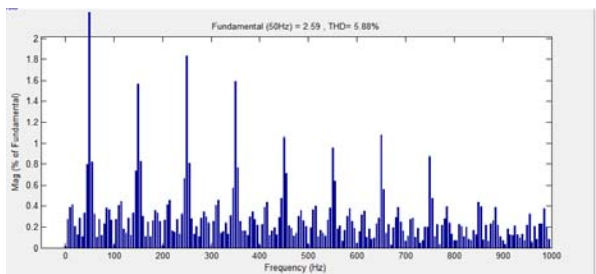

Fig. 10. THD(%) of the proposed drive.

V. CONCLUSION

The new proposed BLDC drive has been simulated in MATLAB Simulink environment. The cuk converter is added prior to VSI which enables us to control the speed of the BLDC drive by controlling the dc-link voltage of VSI instead of controlling the duty ratio of high frequency PWM signals given to VSI. This not only decreases losses but also provide low cost simple motor control technique. The power quality analysis of the proposed drive has given out efficient and satisfactory results. Hence this drive can be used for efficient operation of low power application.

REFERENCES

- [1]. J. R. Handershot and T. J. E Miller, Design of Brushless Permanent Magnet Motors. Oxford, U.K.: Clarendon Press, 2010.
- [2]. J. F. Gieras and M. Wing, Permanent Magnet Motor Technology—Design and

Application. New York, NY, USA: Marcel Dekker, Inc, 2002.

- [3]. B. Singh and V. Bist, "An improved power quality bridgeless Cuk converter fed BLDC motor drive for air conditioning system," IET Power Electron., vol. 6, no. 5, pp. 902–913, 2013.
- [4]. "Limits for harmonic current emissions (equipment input current ≤ 16 A per phase)," International Standard IEC 61000-3-2, 2000
- [5]. B. K. Kushwaha and A. Narain, "Controller design for cuk converter using model order reduction," in Power, Control and Embedded Systems (ICPCES), 2012 2nd International Conference on. IEEE, 2012, pp. 1–5.
- [6]. M. Brkovic and S. Cuk, "Input current shaper using Cuk converter," in Proc. 14th Int. Telecomm. Energy Conf., Oct. 4–8, 1992, pp. 532–539.
- [7]. D. S. L. Simonetti, J. Sebastian, and J. Uceda, "The discontinuous conduction mode Sepic and Cuk power factor preregulators: Analysis and design," IEEE Trans. Ind. Electron., vol. 44, no. 5, pp. 630–637, Oct. 1997.
- [8]. N. Mohan, T. M. Undeland, and W. P. Robbins, Power Electronics: Converters, Applications and Design. New York, NY, USA: Wiley, 2009.
- [9]. R. D. Middlebrook and S. Cuk, "A General Unified Approach to Modeling Switching-Converter Power Stages" International Journal of Electronics, vol. 42, pp. 521–550, June 1977.
- [10]. D. W. Hart, "Introduction to Power Electronics", Prentice Hall, Inc., 1997.
- [11]. Bhushan P. Mokal and K. Vadirajacharya, "Extensive Modeling of DC-DC Cuk Converter Operating in Continuous Conduction Mode", IEEE ICCPCT, 2017.