



DESIGN OF FORWARD INVERTER FOR SMALL SCALE APPLICATIONS

Viranchi C. Pandya¹, Hardik A. Shah², Umang N. Parmar³

^{1,3}Electronics & Communication Department

A.D.Patel Institute of Technology, New V.V.Nagar

²Electrical Engineering Department

A.D.Patel Institute of Technology, New V.V.Nagar

Abstract

In this article, authors propose design of forward inverter for small scale residential applications. The proposed inverter is designed with sinusoidal pulse width modulation (SPWM) at 100 kHz switching frequency at input side of high frequency transformer. At the output rectified sinusoidal is generated and after filtering the pure sinusoidal output is obtained from full bridge. The proposed inverter is useful for single phase utilities. Proposed topology design and analysis is carried out using PSPICE software tool.

Index Terms-Forward Converter; Power electronics; PSpice

I. INTRODUCTION

Design of DC-AC converter is main concerned now days due to tremendous development in renewable energy based low power applications. The selection of the appropriate design topology for DC-AC converter is accountable for the performance of the overall system. In the past, centralize inverters were popular where high voltage DC was fed to the three phase circuits and losses also were high [2]. After string inverters nowadays micro inverters are more popular due to its modular structure and low losses. The output of inverters must be sinusoidal but practically it contents harmonics. The harmonic contents in the inverter depend on switching frequency. A sinusoidal pulse width modulation technique is used to reduce harmonic contents of the inverter. There are two basic categories of single phase inverter as single stage inverter and multiple

stage inverters. A single stage inverter is an inverter with only one stage of power conversion, which will boost up the low input dc voltage to a high ac voltage. A multi stage inverter is an inverter where two stages are there, first stage is to convert low input dc voltage into high dc voltage and then it is converted into ac voltage [4].

II. FORWARD TOPOLOGY

This section provides operation of forward inverter topology. Fig. 1 shows the schematic diagram of forward converter. When M1 is turned ON as shown in Fig 2 the voltage across primary winding is V_{dc} . The primary current starts to build up and transfers energy from the primary winding to secondary winding and into AC line filter and the load through the rectifier diode D1 which is forward biased.

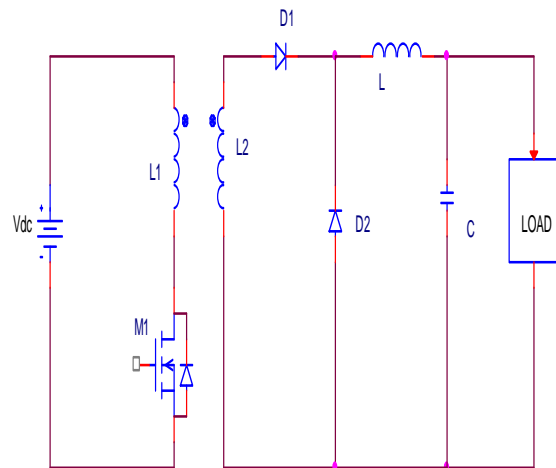

Fig. 1 Forward Converter

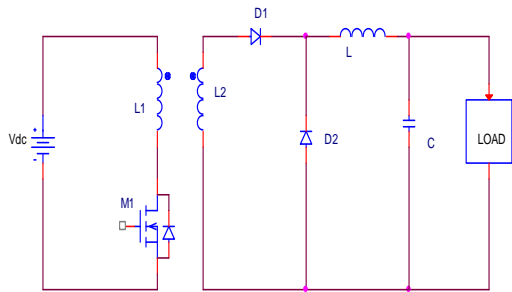

Fig. 2 Conduction Model1: Forward Converter

When M1 is turned OFF as shown in Fig. 3 the polarity of the transformer voltage reverses. This causes D1 to turn off and D2 to turn ON, while D2 is conducting, energy is delivered to load through the inductor L [1].

Single PWM, Multiple PWM, SPWM, Modified SPWM, Phase displacement control PWM are the popular voltage control techniques of single phase inverter. Among all the voltage control methods, Sinusoidal Pulse Width Modulation (SPWM) is suitable for voltage control as it has lower Total Harmonic Distortion.

By increasing the SPWM frequency, harmonics get reduced after filtering. Here SPWM is applied to the input switch of isolated forward converter topology which provides high efficiency.

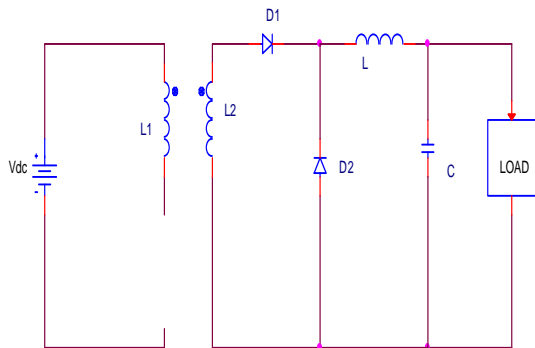

Fig. 3 Conduction Mode 2: Forward Converter

III. DESIGN PARAMETERS

This section discusses design parameters of various components used for forward inverter topology.

(a) Design of transformer

The output voltage requirement is 310 V_p and input voltage is 36V dc. Thus the turns ratio of

the transformer is calculated by using equation (1)

$$\frac{N_2}{N_1} = \frac{V_{Out}}{V_{in}} = \frac{310}{36 \times 0.5} = 17.22 = 18 \tag{1}$$

Step 1: Primary turns selected to satisfy the AC voltage stress and core saturation property is calculated by using equation (2).

$$N_p = \frac{VT}{BA_e} = \frac{V}{FBA_e} = 1.86 \tag{2}$$

Where,

N_p= Minimum Primary turns

V= Maximum Primary DC Voltage

T = Maximum Period for MOSFET

F= Switching Frequency =50-100 kHz

A_e= Effective Center pole area of the curve (0.97 cm²)

B= Magnetic Flux Swing typically 200mT

Step 2: The value of primary inductance of coil wound on core is calculated by using equation (3)

$$L_p = A_L N_p^2 \geq 10.40\mu H \tag{3}$$

Where,

L_p = Primary inductance value

L_s =Secondary inductance value

A_L= 3 μH

Secondary inductance value is calculated by following equation

$$L_s = N^2 L_p \geq 3mH \tag{4}$$

The proposed topology is designed using the following input parameter values as shown in Table 1

Parameter	Value
Input Power	350 W
Input Voltage	36 V dc
Input Current	9.75A
Switching Frequency	100 kHz
Simulation Tool	Orcad Capture CIS Lite 17.2 & Orcad Capture Pspice Lite 17.2

Table 1. Input Parameters of Forward Inverter

In the proposed inverter the specifications of the input MOSFET and Diode are shown in Table 2 and Table 3 respectively.

Parameter	Value
Drain to Source Voltage	60V
Drain Current	36A
Drain to Source ON state Resistance	$R_{DS}=0.028\Omega$
Turn ON delay Time	14ns
Rise Time	110ns
Turn OFF delay Time	45ns
Fall Time	92ns

Table 2 Input MOSFET Specifications (IRFZ40)

Parameter	Value
Maximum Recurrent Peak Reverse Voltage	1000V
Maximum RMS Voltage	700V
Maximum DC Blocking Voltage	1000V

Table 3 Rectifier Diode Specifications (MUR4100)

Inductor is designed in such a way that it can tolerate 10% of current. The compromised value of the inductor is 4mH. Capacitor can be calculated by choosing the corner frequency 10% of the switching frequency. The compromised value of the capacitor is 2μF.

$$L = \frac{V_{in}}{4 \times f_s \times \Delta I_{pp}} \quad (5)$$

$$f_c = \frac{1}{2\pi\sqrt{LC}} \quad (6)$$

Where,

f_c = Corner Frequency =10 kHz

f_s =Switching Frequency =100 kHz

L= Filter Inductor

C=Filer Capacitor

V_{in} = Input DC Voltage

ΔI_{pp} = Inductor Ripple Current

The output MOSFET specifications are as shown in Table 4

Parameter	Value
Drain to Source Voltage	500V
Drain Current	21A
Drain to Source ON state Resistance	$R_{DS}=0.30\Omega$
Turn ON delay Time	35ns
Rise Time	120ns
Turn OFF delay Time	130ns
Fall Time	98ns

Table 1 Output MOSFET Specifications (IRF460)

IV. RESULTS

Design is carried out as discussed in section II. Simulation Model of the proposed inverter is developed in PSpice software tool. Following Simulation results are obtained for Input current, output voltage, output current of the proposed design topology . FFT analysis of the output voltage is also presented.

i. Input current

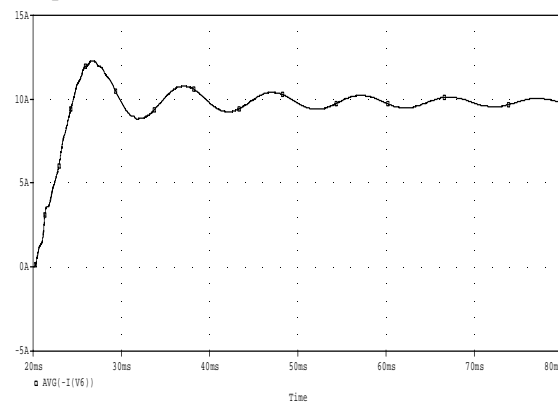

Fig .4 Avarage Input Current from dc source

ii. Output voltage

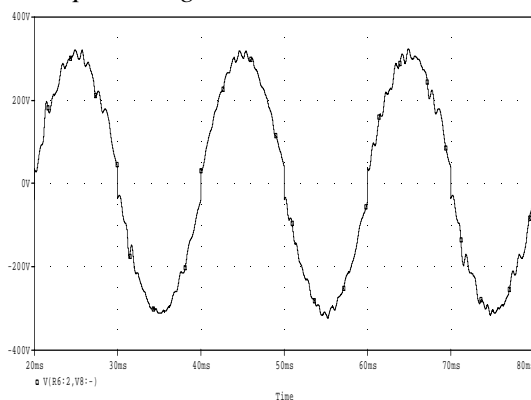

Fig. 5 Output Voltage

iii. Output Current

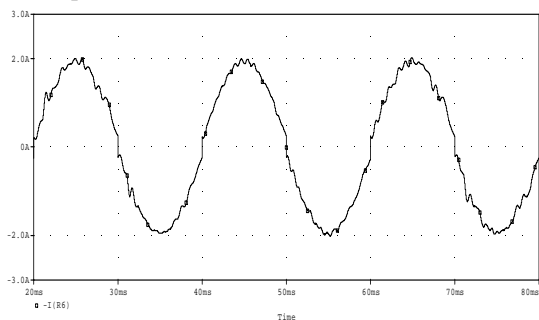
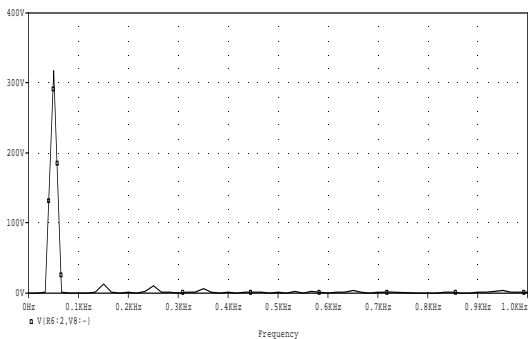

Fig .6 Output Current

iv. FFT of Output voltage



Fig

.7 FFT of output voltage

Parameter	Value
Output Power	302 W
Output Voltage	310V (Peak)& 220 V (RMS)
Output Current	1.93A Peak & 1.37A RMS
Power Conversion Efficiency	86.18%
Total Harmonic Distortion	6.67%

Table 5 Output Parameters of Forward Inverter

The output parameters of the proposed inverter are as shown in Table 5.

V. CONCLUSION

In this paper, detailed simulation of forward micro inverter is performed for 350W load at 100 kHz switching frequency for single phase small power applications. A single switch is used at input side and rectified sine is generated at output side. To make utility equivalent ac of 220V (rms) or 310V (peak) at 50Hz frequency, full bridge is used at secondary side of high frequency transformer after filter. The overall power conversion efficiency is 86.18% with less than 10 % total harmonic distortion.

ACKNOWLEDGMENT

The authors thank Power Electronics Laboratory of Electronics & communication department & Electrical Engineering Department Laboratory of of A.D.Patel Institute of Technology, New V.V.Nagar, Gujarat, India for their support.

REFERENCES

- [1] D. Meneses, O. García, P. Alou, J. A. Oliver and J. A. Cobos, "Grid-Connected Forward Microinverter With Primary-Parallel Secondary-Series Transformer," in *IEEE Transactions on Power Electronics*, vol. 30, no. 9, pp. 4819-4830, Sept. 2015
- [2] M. Calais, J. Myrzik, T. Spooner, and V. G. Agelidis, "Inverters for single-phase grid connected photovoltaic systems-An Overview", in *Proc. IEEE PESC'02*, vol.2,2002,pp. 1995-2000
- [3] S. B. Kjaer, J.K. Pedersen, and F. Blaabjerg, "Power Inverter topologies for photovoltaic modules-A review", in *Conf. Rec. IEEE-IAS Annu. Meeting*, vol. 2, 2002, pp. 782-788
- [4] Muhammad H. Rashid, *Power Electronics Circuits, Devices and Applications*, 3rd Edition
- [5] *Switching Power Supply Design* 3rd edition Abraham I Pressman
- [6] V. Pandya and A. K. Agarwala, "Efficient PV micro-inverter with isolated output," *2012 IEEE Fifth Power India Conference*, Murthal, 2012, pp. 1-5
- [7] V. Pandya and A. K. Agarwala, "Diagonal PV micro-inverter with isolated output," *2012 IEEE 5th India International Conference on Power Electronics (IICPE)*, Delhi, 2012, pp. 1-5
- [8] Hardik A.shah, Satish K.shah and Viranchi C Pandya. Article: DSP based Pulse Generation for Induction Motor Speed Control. *International Journal of Computer Applications* 122(14):1-5, July 2015
- [9] Hardik A. Shah, Satish K. Shah, Rakesh M. Patel, (2015) "Signal processing analysis of DSP based PWM generation for high switching frequency voltage source inverter", *World Journal of Engineering*, Vol. 12 Issue: 5, pp.499-506