



NEURAL NETWORK AND FUZZY LOGIC BASED CONTROLLER FOR TRANSFORMER PROTECTION

Vikramsingh R. Parihar¹, Manisha Thakare², Sagar D. Nimkar³, Roshani S. Nage⁴, Anagha P. Dhote⁵
Prof Ram Meghe College of Engineering and Management, Badnera, Amravati

Abstract

One of the most powerful and efficient techniques of analyzing transient voltage and current signals is wavelet transform. Compare with fast Fourier transform, wavelet transform gives better results in analyzing signals containing sharp spikes. Differential protection schemes are widely used by electric companies to protect power equipment. Usually, various techniques are used in power transformer protection. This paper offered novel control technique for transformer protection. This protection approach is based on extracting the fundamental components present in differential currents. The neural network based fuzzy logic controller is used to design protection relay for transformer. The simulation is done by MATLAB/SIMULINK software and results are revealed clearly in this paper.

Index Terms: Fast Fourier transform, wavelet transform, artificial neural network, fuzzy logic controller

I. INTRODUCTION

Transformer is exclusive primary plant equipment within a power system network which needs to be insulated rapidly and reliably in the event of a fault. Utilities have a responsibility towards the consumer to provide reliable and continuous power in the network without causing a large blackout or cascade power failure. Inrush and fault currents comprise of DC component and harmonics and it is a perplexing task to estimate and eliminate DC component which occur during transients. Inrush current happening due to switching of a power

transformer on no load may lead to resonance. A resonance is said to have ensued in the power system when there is a slow damping of inrush current. In a typical normal operating scenario, the primary and secondary current of a power transformer maintains equilibrium but when an internal fault occurs, this balance is disturbed. The magnitude of the fault current depends upon zone of occurrence, the type of the i.e. phase to phase, phase to earth etc), vector group of transformer (i.e. star-star, star-delta, delta-star). The magnitude of an inrush phenomenon is usually 10-15 times the normal [1-6].

MAGNETIZING INRUSH CURRENT

This occurrence of transient magnetizing inrush occurs in the primary side of transformer when it is switched on. This current appears as an internal fault and it is sensed as a differential current by the differential relay. The value of the first peak of magnetizing current may be as high as several times of the peak of the full load current. The factors which influence the magnitude and duration of magnetizing inrush current are described as follows.

- The input supply of voltage level.
- The instantaneous value of the voltage waveform at the moment of closing Circuit Breaker.
- The value of the residual magnetizing flux.
- Depends on the sign of the residual magnetizing flux.
- Type of iron laminations used in transformer core.
- The saturation of flux density in the core of transformer.
- The final impedance of the supply circuit.
- The size of the transformer.

The effect of the inrush current on the relay is false tripping the transformer without of any existing type of faults. As the inrush current flows through the primary side of the power transformer and therefore the differential current will have a significant value due to the existence of current in only one side. Thus the planning of relay is to recognize that this current is a normal phenomenon and not to trip due to this current. Hear figure 1 shows the transient period and steady state period of a current that flows through the power transformer and this transient period is caused due to the inrush current phenomenon.

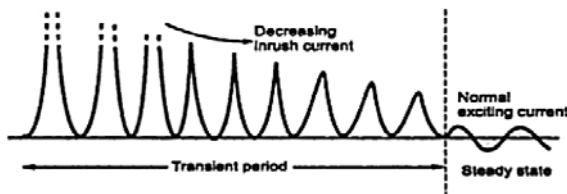

Fig. 1: shows a transient period due to inrush current

II. POWER QUALITY PROBLEMS DERIVED FROM MAGNITIZING INRUSH CURRENT

The magnetizing inrush current can be considered as a distorted wave with two kind of disturbances.

2.1 Unbalance

2.2 Harmonics

Let us describe these problems caused by inrush current one by one.

2.1 Unbalance

Current unbalance can not be considered as disturbance. Asymmetrical loads produce unbalanced currents. In the same way the magnetizing inrush current produces unbalanced current during magnetization. This condition can be used in parallel with the second harmonic in order to know what it is happen during the connection of the transformer.

2.2 Harmonics

The current demand by the transformer during the magnetization contains all orders of harmonics. However only the second and third harmonics are relevant. The dc component can also be significant during the first cycles depending on the residual flux. The most dominating harmonics are as follows[8].

I. DC or offset component: A dc component can be found almost at all times in the inrush current, with different values for each phase of the three phase system. The dc component is the function of residual flux.

II. Second harmonic: The second harmonic is present in all inrush current of all three phases. The value of the second harmonic is a function of the degree of saturation.

III. Third harmonic: Third harmonics in the inrush current can be found with the same magnitude that second harmonics. They are produced by saturation.

IV. Higher harmonics: Harmonics of high order are present with different values. Actually, they have small values so can be neglected.

III. TECHNIQUES TO DISTINGUISH INRUSH AND FAULT CURRENT

There are several ways of discriminating fault and inrush condition for protection purpose[9-10].

- Desensitization method is no longer being practiced.
- Wave shape recognition methods are still relatively new and not widely practiced.
- Harmonic based methods

These methods are widely practiced. The inrush current has a large harmonic component which is not present in fault currents. Inrush currents generate harmonics with second harmonic amplitudes as high as 65% of the fundamental. Thus SHR (second harmonic ratio) is used to discriminate inrush current from fault current such that, if SHR is less than threshold value then that condition can be considered as fault and if SHR is more than threshold value then there is inrush current condition

Using artificial intelligent technique

New techniques like artificial intelligent technique (fuzzy logic controller) can help to discriminate between magnetization and fault conditions. Let us elaborate this technique and evaluate its advantages over others.

IV. THE FUZZY LOGIC CONTROLLER

The ideas of fuzzy set and fuzzy control are introduced by Zadeh. Fuzzy logic controllers are applied to many systems with linearity and uncertainty. The most common types are the error feedback fuzzy controller, which is called fuzzy logic controller (FLC). In conventional FLC, there are also PD-type FLC, PI-type FLC and PID type FLC [12].

The FLC having the following stages:

4.1 Fuzzification:

Fuzzyfication implies the process of the transforming the crisp values of inputs of a controller to the fuzzy domain.

4.2 Knowledge base:

The knowledge base of FLC comprises of data base and rule base

Data base:

- It is used to deliver necessary information for functioning of fuzzification module, rule base and
- defuzzification module.

Rule base:

- The function of rule base is to represent in a structured way the control policy.

4.3 Fuzzy Inference System:

Fuzzy inference system has a simple input –output relationship. Input data from the external world is processed by the fuzzy inference system to produce the data the events having place in this process are referred as the basic fuzzy inference algorithm. Mamdani fuzzy is one of the examples of fuzzy inference system.

4.4 Defuzzification:

It is a process of transforming the fuzzy sets assigned to a control output variable into a crisp value. There are various methods of defuzzification but we used the mean of maximum method (MOM).

Discrete Wavelet Transform: Different windowing techniques are applied to calculate the current and voltage phases which causes significant time delay for the protection relay. Also, accuracy is not completely assured. Due to increased standards of the delivered energy quality such as IEEE 519, high performance

algorithms should be taken into account. The continuous nature of the wavelet function is set aside to the point of sampling the scale-translation grid used to represent the wavelet transform is independent of the sampling of the signal under analysis. The Fourier transform is a useful tool to analyze the frequency components of the signal. However, if we take the Fourier transform over the whole time axis, we cannot tell at what instant a particular frequency rises. Wavelets are a mathematical tool, that can be used to extract information from many kinds of data, including audio signals and images. The Fourier transform is a useful tool to analyze the frequency components of the signal. However, if we take the Fourier transform over the whole time axis, we cannot tell at what instant a particular frequency rises. Wavelets are a mathematical tool, that can be used to extract information from many kinds of data, including audio signals and images. The discrete wavelet transform (DWT) is an implementation of the wavelet transform using a discrete set of the wavelet scales and translations following some defined rules. In other words, this transform declines the signal into a mutually orthogonal set of wavelets.

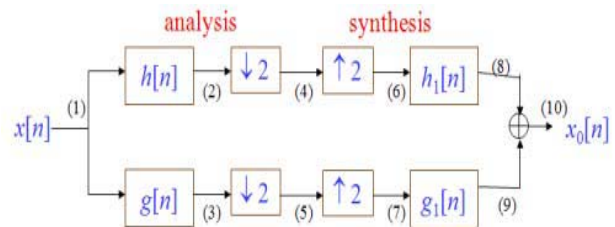

Fig. 2: Wavelet transform

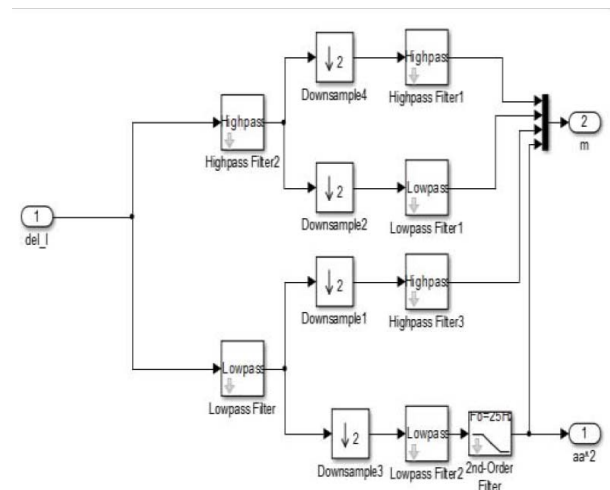

Fig. 3: Simulink model of wavelet transform

V. SIMULATION AND RESULTS

The 13.8/138V system is modeled by using MATLAB/SIMULINK software. As shown in Fig.5 The source is simulated by an equivalent 50 Hz 30MVA Synchronous machines with 500 MVA transformer and 50 MW load is connected in parallel. A .8(13/138) kV star to delta connected transformer is employed with its neutral grounded. The generator X/R ratio is 7. The primary winding voltage R(pu) and L(pu) are 13.8 kV.0.0078 and 0.259 respectively, and secondary winding voltage is R(pu) and L(pu) are 138 k.V 0.0078 and 0.259 respectively. The load taken here is 50 MW and 10 MVAR.

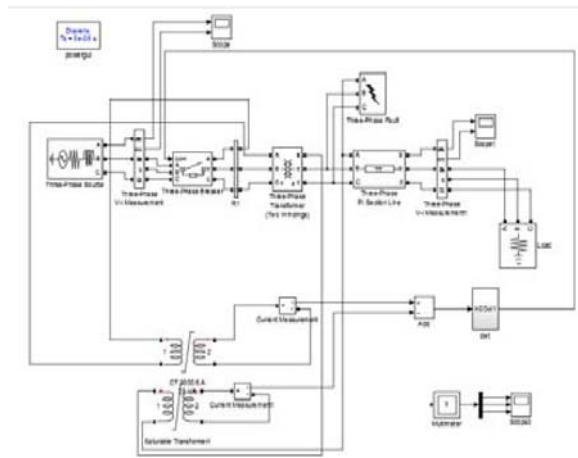

Fig. 4: Matlab Simulink Model

A. Simulation of Neuro fuzzy controller

To identify the fault currents in transmission system various technique are used. The current in primary and secondary side of the transformer are measured by using current transformer. From this differential current approximation and detailed coefficients are detected by discrete wavelet transform.

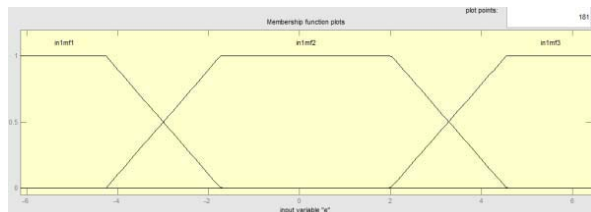

Fig. 5: (a) Membership function of e

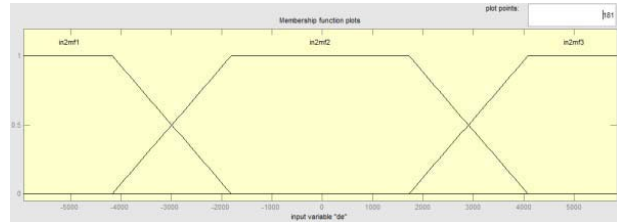

Fig. 5: (b) Membership function of de

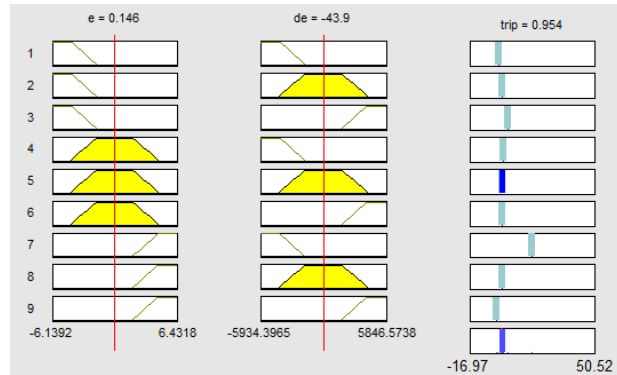

Fig. 6: Rule viewer

B.Result

The Voltage and current waveforms for various conditions (without fault, with fault and with tripping algorithm) are shown in the Figs below. Fig.10(a) - (b) and Fig.11(a) – (b) represented Voltage and current waveforms under normal condition at no fault in a transmission line.

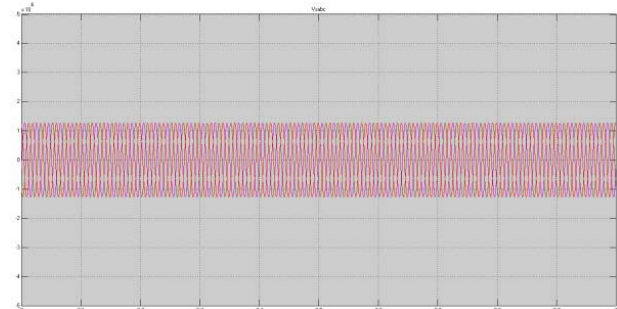

Fig.7: (a) Grid V under normal condition

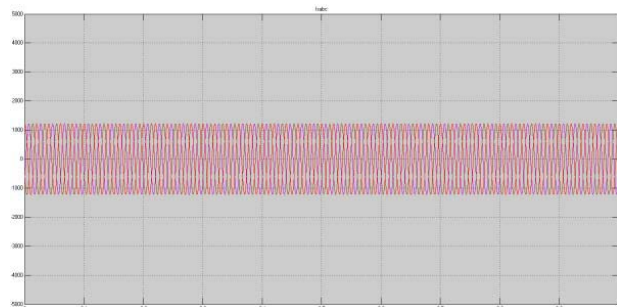

Fig. 7: (b) Grid I under normal condition

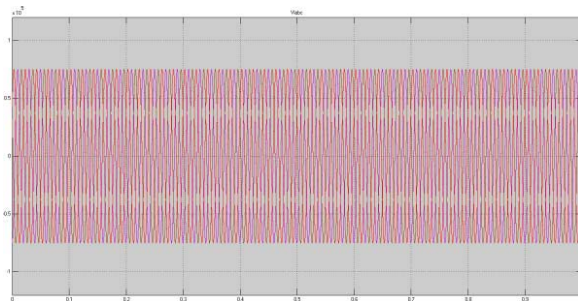

Fig. 8: (a) The Load V under normal condition

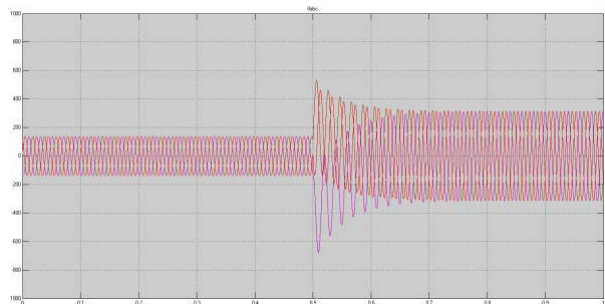

Fig. 10: (b) The Load I during Three phase fault

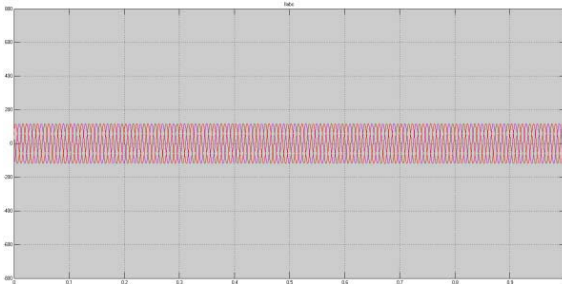

Fig. 8: (b) The Load I under normal condition

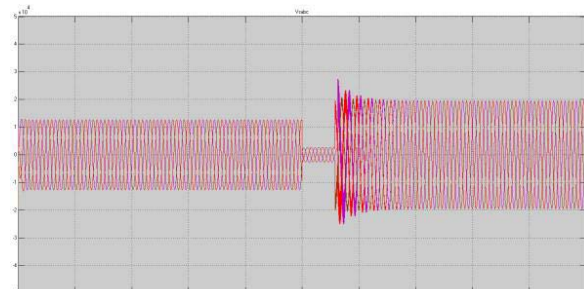

Fig. 11: (a) The Source V with relay protection

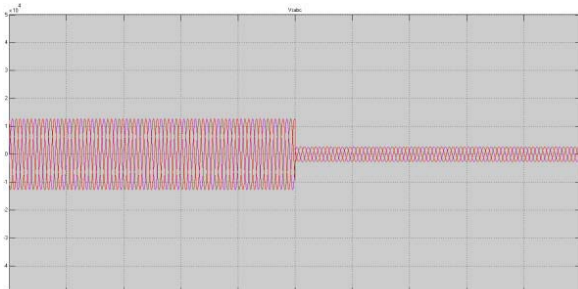

Fig. 9: (a) source V during Three phase fault

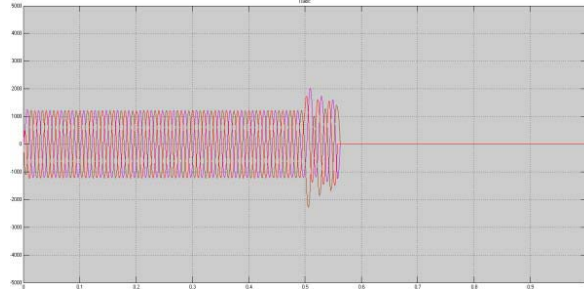

Fig. 11: (b) The Source I with relay protection

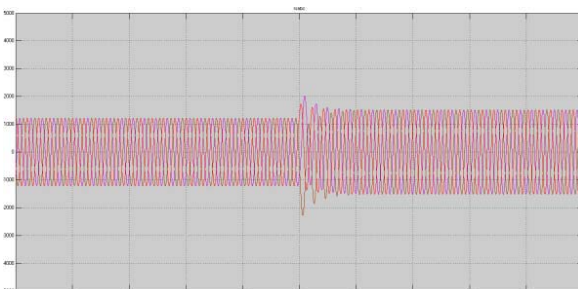

Fig. 9: (b) source V during Three phase fault

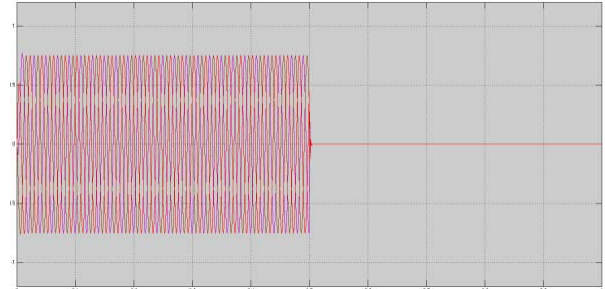

Fig. 12: The Load V with relay protection

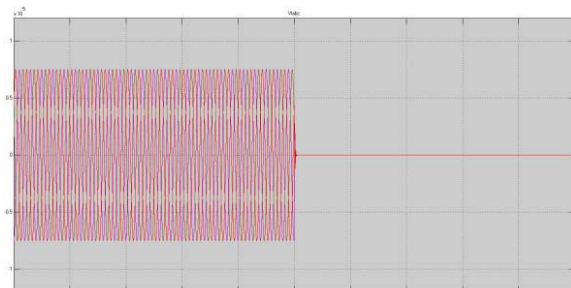

Fig. 10: (a) The Load V during Three phase fault

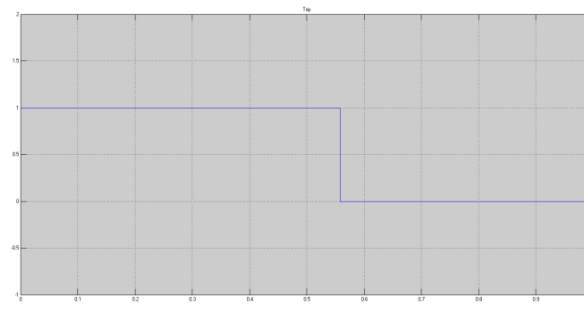

Fig. 13: The Trip signal to circuit breaker

VI. CONCLUSION

The simulation results show that the protection system based on wavelet transform is suitable for relay protection for all types of fault. A simple decision making logic scheme using fuzzy logic ANFIS is presented for the developed technique for faults identification. The simulation waveforms show that the Neuro fuzzy based relays are tripping properly during the faulty condition. The extensive simulation results presented show that the proposed technique needs very simple input signals.

References

[1] P.Bastard, M.Meunier, and H.Regal, Neural network- based algorithm for power transformer differential relays, IET Generation Trans. & Distr., vol.142, pp.386- 392,1995.

[2] P.L.Mao, R.K.Aggarwal, A wavelet transform based decision making logic method for discrimination between internal faults and inrush current in power transformers, Electric Power System Research, vol. 22,pp. 389-395,June 2000.

[3] P. Liu, O. P. Malik, C. Chen, G. S. Hope, and Y. Guo,"Improved operation of differential protection of power transformers for internal faults", IEEE Trans. Power Del.,vol. 7, no. 4, page(s): 1912-1919, Oct. 1992.

[4] Biswarup Das; J.Vittal Reddy, "Fuzzy-Logic-Based Fault Classification Scheme for DigitalDistance Protection", IEEE Transactions on PowerDelivery, Vol.20, Issue 2, Page(s): 609 – 616, Apri2005

[5] Ramsis S. Girgis, Ed G. teNyenhuis, —Characteristics of Inrush Current of Present Designs of Power Transformers,IEEE, 1-4244-1298-6/07/\$25.00 ©2007 IEEE.

[6] M. Fedi, et al., Joint Application of Continuous and Discrete Wavelet Transform on Gravity Data to Identify Shallow and Deep Sources, International Journal of Geophys, 156, 7-21, 2004.

[7] M.A. Rahman, B. So, M. R. Zaman, M.A. Hoque", Testing of Algorithms for A Stand-Alone Digital Relay for Power Transformers, IEEE Transactions on Power Delivery, Vol. 13, No. 2, April 1998.

[8] EI Safty.S, Gharieb,S, EI Latif Badr.A, M.Mansour.: A wavelet fuzzy expert technique for classification of power transformer transients.

In: Internationalconference on power system technology, p. 1-5, June2006.

[9] D. Barbosa, D.V. Coury and M. Oleskovicz, "New approach for power transformer protection based on intelligent hybrid systems" IET Generation, Transmission and Distribution, vol. 6, no. 10, pp. 1003-1018, 2012.

[10] A. Zilouchian and M. Jamshidi, Eds., Intelligent Control Systems Using Soft Computing Methodologies. Boca Raton, FL: CRC, 2000.

[11] Z.Kovacic and S. Bogdan, Fuzzy Controller Design. Boca Raton, FL: CRC., 2005.

[12] Vikramsingh R. Parihar, Sagar D. Nimkar, Snehal Warudkar, Rajvi Deshmukh, Manisha Thakare, Power Transformer Protection using Fuzzy Logic based Controller, International Journal of Engineering Research, Volume No.6, Issue No.7, pp : 366-370, 2017.