



DESCRITIZATION OF A STRUCTURAL MEMBER FOR LINEAR STATIC ANALYSIS

Swapnil P. Bandgar

Abstract

In this paper, the discretization for a structural member like lifting beam for linear static analysis is discussed for the purpose of understanding of variation in the analysis results and the stresses produced due to use of various meshing attributes and also analysis results are discussed. Lifting beams are used to assist in the hoisting process. Lifting beam is a solid, fabricated metal beam, suspended from a gantry, designed to provide multiple lifting points. FE model should represent the exact physic of the actual structure. This paper also includes the discussion about meshing approach for structure in static analysis with subassemblies having line, sliding contacts. Hypermesh, a tool from 'Hyperworks' is used to mesh the components and NASTRAN is a solver. The results of analysis are shown in pictorial forms for stress induces with the use of Hyperview.

Keywords: discretization, structural member, Hyperworks. NASTRAN

I. INTRODUCTION

Structural members like lifting beam, hoist, and frames are widely used to in mechanical, civil, aerospace industries. They are designed to lift raw material, machinery, engines, etc. so these the tools have to be well qualified. Such a structural members are made up of various component like beams, angles, sheets, tubes and blocks. In heavy application beams may made-up with sub-aassemblies. These sub-assemblies may have some relative motion between them to adjust the mounting points and its functionality. Also these contains some standards components like locking pins, nuts, bolts, washers, hydraulic piston cylinder, etc. which may be the part of mechanisms or the part of frames. So while analyzing such members/tools discretization

plays an important role. The results from any finite element analysis is as good or bad as the finite element model. It is therefore necessary to perform model verification systematically to ensure correctness and accuracy of the model. Standard finite element model checks and verifications are available from references like NAFEMS, Nastran Manuals, Text books etc. All standard pre-processing software provide facility of model quality checking with standard verifications.

Generally speaking, numerical analysis of structure problems involves the modeling of structure, its discretization and implementation of its physics. Currently, the standard finite element method is still the most reliable and widely-used numerical tool in linear, non-linear structural analysis, frequency response analysis and for many more domains found in literature review [1] [2].

The paper, Simulation of welding using MSC.MARC by J.Fang [3], discuss about the element selection for simulation of the welding in different situations, and numerical results are compared to actual measurements.

Mr. Adrian Viisoreanu [4], discussed the techniques applicable to the solid modelling of the single shear pin joint in MSC/NASTRAN and residual stresses also considered. The objective was to determine the stress concentration factor in the shear pin receptacle and the bearing load distribution along the length of the pin, using finite element modeling in MSC/PATRAN and finite element analysis with

MSC/NASTRAN. Technique to mesh around the holes is also suggested. He concluded that 'Adaptive Gap Element' was a useful feature for this model and suggested essential elements to represent gap between pin, bushing and fitting plate.

Mr. John McCullough [5], discussed about solution 101 i.e. linear static analysis with use of multi-point constraints MPCs elements and single point constraints SPCs elements and entry of PARAM and GFORCE card for MSC/NASTRAN. The input deck of MSC/NASTRAN is also discussed. Also suggested some output requests like MPC FORCES and SPC FORCES for validation of the model.

Mr. Y.T. Chung [6], suggested a general procedure for finite element model check e.g. mass property check, strain energy check, rigid body frequency check etc. He mostly discussed about the dynamic analysis of the model.

Mr. Prakash Mohanasundaram [7], discussed about use of the elements to represent solid, shell and 1D members for structural analysis of heavy vessel. Also suggested the use of Plate, PBEAM, and Spring elements, stiffeners.

Mr. John E. Schiermeier [8], discussed the method to connect the dissimilar meshes with interface element called Null-Shell in Global/Local analysis and its formulation. Cantilever beam, Scordelis-Lo roof and Square plate with circular hole are used to demonstrate the results. Null-Shell is a membrane like structure with PSHELL property with 0.01mm thickness.

Mr. John E. Schiermeier [9], in his 2nd paper on methods to connect the dissimilar meshes, surface interface elements, being implemented in MSC/NASTRAN for solid and shell p-element faces, are presented with examples.

Mr. John E. Schiermeier [10], in his 3rd paper on methods to connect the dissimilar meshes, the shell-to-solid transition interface element, being implemented to connect dissimilar p-element edges with p-element faces is presented with examples. Patch test is also discussed.

II. CAD MODELLING AND LOAD CASE STUDY

A. CAD Modelling

CAD modelling of the structure should be well prepared. Because it the input to meshing tool or one of the main inputs for analysis. The mistakes done in the CAD model will carried out throughout the analysis, which gives wrong results. So CAD model should be verified once or twice depend upon complexity of the structure. For HyperMesh geometry can be imported in .IGES or STEP formats.

B. Load Case Study

Load case study is also an important phase in analysis. Load case study involves the study of working and use of structure for which it is designed. A load case is a combination of different types of load with safety factors applied them. A structure is checked for strength and serviceability against each and every load cases it is likely to experience during its lifetime. Load cases are depend on the engine stripping sequence in case of MRO application. Thorough study of working helps to develop the load cases.

III. DISCRETIZATION OF THE MODEL

Finite element analysis (FEA) is a numerical technique of obtaining solutions to the differential equations that describe or approximate a problem. FEA uses the finite element method (FEM) to discretize a region (CAD model) into many smaller regions (elements). Each element is joined to adjacent elements at points (nodes). Loads and boundary conditions are applied to the nodes to represent the problem to be solved. Differential equations are created at each element and approximately solved. The assembly of all the equations solutions describes the behavior of the entire region. Displacements are calculated at nodes. Stresses and strains are calculated within the elements. Element quality is critical to correct results, particularly stresses/strains.

Geometry study and load case study is important activity before proceeding for meshing of any model. As the beam is made up of five different sub-assemblies and it is required to position them as per load cases. So sub-assemblies are meshed separately.

Before creating IGES files all standard components e.g. nuts, bolts, washers, shafts, gears, racks, couplings, some supporting members, and hand wheels, etc. are removed.

Geometry is categorised as 1-d, 2-d, or 3-d based on dominant dimensions and type of element is selected accordingly.

1-d elements are used as; Rigid (yellow colour elements in figure 1) for nuts, bolts and washer arrangements, loading the beam with concentrated masses and to apply the common constraint condition to a set of element nodes, also BEAM can be used with the additional input i.e. area of cross section

2-d elements are used sheet metal parts having width to thickness ratio greater than 20 e.g. C-channels, supporting plates, rectangular tubes (blue colour elements in fig. 1), etc.

3-d elements are used when all the three dimensions are comparable i.e. mounting blocks (grey colour elements in fig 1), parking position blocks, etc.

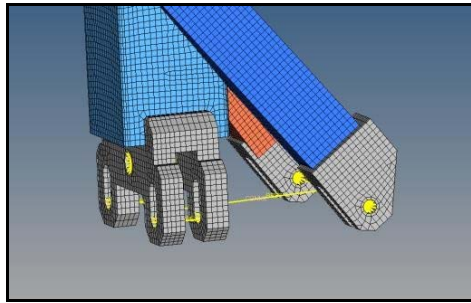

Figure 1. 1-d, 2-d and 3-d Elements

Other element types are used as; CONMASS to apply concentrated mass at CG of the engine; SPC to apply constraints at single point; FORCE to apply various forces acting on members

Selection of element size is depend on the overall dimensions of the model, the dimension of the smallest component in the model, accuracy of results required and computing capacity of system.

Quadrilaterals and hexagonal elements are preferred over triangular and tetrahedron elements.

1-d components are used for bolts and washers also use to load the model with engine weight. All the 2-d components are meshed at their mid-surfaces then assigned respective geometry and material properties to them. 3-d components are meshed and connected to 2-d elements with the help of nullshell 2-d elements with thickness 0.01mm.

All the welding are meshed by using 2-d elements as per the weld size, with direct connections as shown in fig 3, blue plate is welded (green) to red plate.

Sliding contact between mounts and welded beam attended with the help of the rigid elements having degree of freedom 2, i.e. free in X and Y direction as sliding plane and restricted in Z direction, perpendicular to sliding plane as shown in fig. 2, RBE2 elements in sky blue colour. Line contact between rollers and its guide is attained with help inline rigid elements with zero degree of freedom as shown in fig. 3

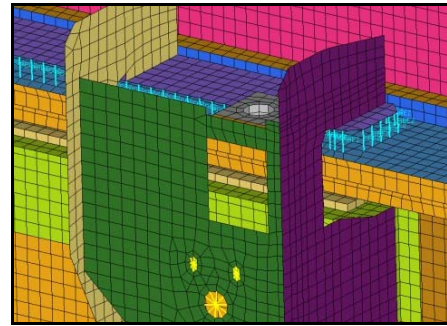

Figure 2. RBE2 elements sliding contact

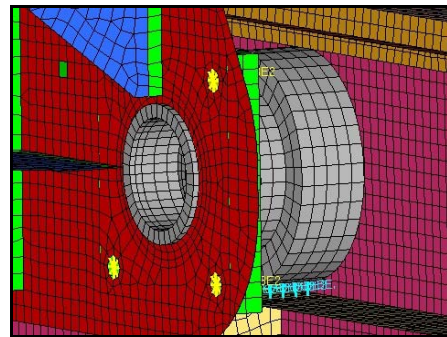

Figure 3. Line contact

To represent the fasteners which are used to clamp two components can be meshed with rigids element RBE2 or BEAM element. Experience plays very important role in selection of element type. Rigid element don't take the stress, it just passes the motion and forces from one end to other end. Beam elements takes stress, so that if it is important to know the stresses in the bolts, BEAM element can be used. In figure 4 the rigid elements are used to represent the bolts. This will stick those three plates together. Outer two plates are used as reinforcement for the middle plate. And as per the location of the bolts it is not required to know the stress, so it is meshed with the rigids.

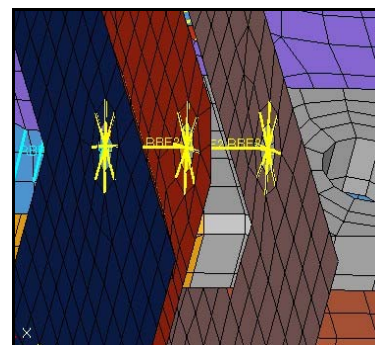

Figure 4: Rigids for bolts

Usually bolts and nuts are used with the washers. To represent the washer in the meshing the rigids can be used as shown in figure 5. The diameter of the rigid circles is the outer diameter of the

washer. The outer nodes of the rigids are dependent nodes and common node is independent node.

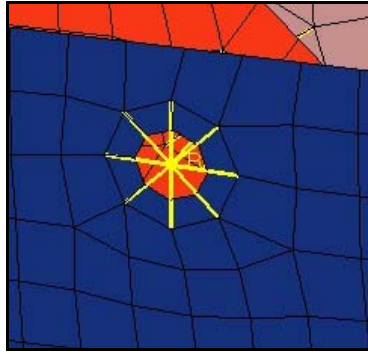

Figure 5: Washer

Locking pins made for special applications, should be meshed by using BEAM element.

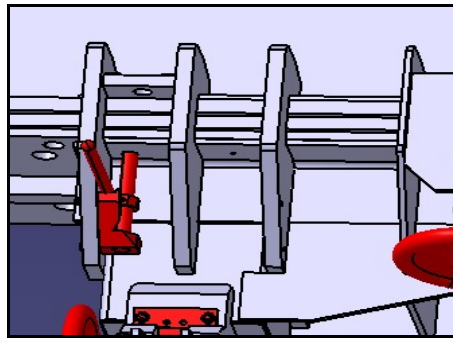

Figure 6: Pin location

If it is meshed with rigid elements then the results are as shown below

At pin location max. von-mises are found to be 167.6 MPa, which are compressive stress and locking pin meshed with rigids is not sharing any stresses. So stress shown are higher than the actual. In real world such pins can share the stresses, but rigid elements never share the stresses. So BEAM, stress sharing element must be used at such critical position (Figure 7). And also in actual model a solid block is used to guide the pin, which may also contribute in sharing the stresses.

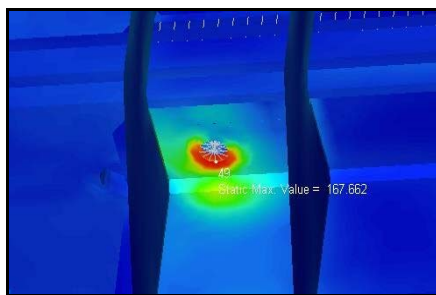

Figure 7: Max. stress area near pin

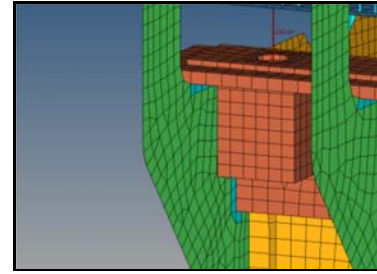

Figure 8 Re-meshed model

Some plates are used as reinforcement as shown in figure 9, as per conventional rule such plates should be meshed with 2-d elements. In such cases welds plays the role to support the member on outer peripheral elements only, and all the elements laying inside-portion of the member will be left hanging with no physical support. Reaction loads will come on outer member only and produces the errors in the results. So such components must be meshed with 3-d elements as shown in figure 8. (brown colour)

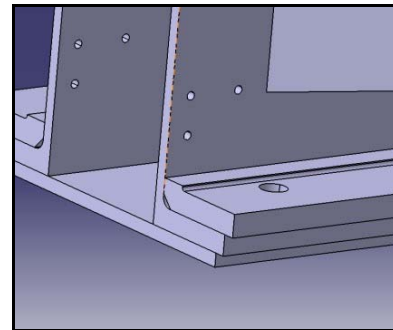

Figure 9. Guide for mounts (top plate) is supported on two members

Considering all above corrections, model is remeshed and analysed again. Stress at critical area is reduced to 58.5 MPa and stress in locking pin is 47 MPa. (figure 10), maximum deflection value is remained as it is.

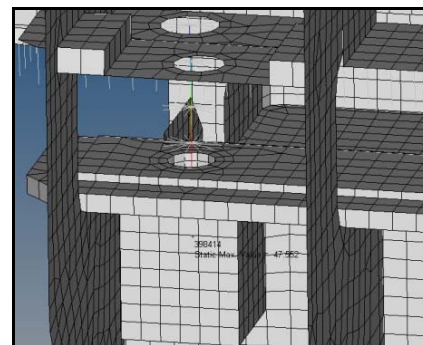

Figure 10. stresses in locking pin

IV. FE MODEL – QUALITY ASSURANCE

The results from any finite element analysis is as good or bad as the finite element model. It is therefore necessary to perform model verification systematically to ensure correctness and accuracy of the model. Standard finite element model checks and verifications are available from references like NAFEMS, Nastran Manuals, Text books etc. All standard pre-processing software provide facility of model quality checking. With standard verifications. [6]

Geometry Confirmation:

It is check for dimensions and correct geometry standard used for meshing. Use Drawings and/or CAD models is necessary. Both the CAD model and HM model are imported into the HyperMesh tool and geometry of HM model is verified with CAD model manually.

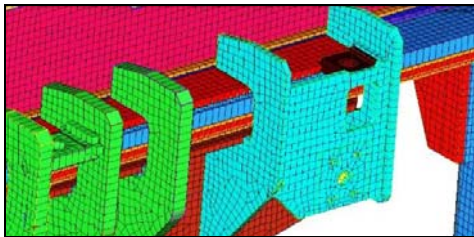

Figure 11: Geometry Confirmation

Usage of Appropriate Element Types:

Here, it is checked whether the right elements used to simulate the expected structural behavior. Results are highly dependent on the element type chosen, as discussed in earlier, Rigids can be used to represent bolts and locking pin as well as the sliding contacts. Also at some location it is important to use CBEAM element for nonstandard pins e.g. Locking pins at each mount.

Model Quality:

It is the check of FE Mesh quality attributes element quality parameters. Quality of the elements are checked. A direct run for quality check is available in HyperMesh.

Element Geometry and Material Properties check: Element geometry properties check includes verification of beam/bar sectional properties Area, Inertia, thickness, offsets etc. Material properties check includes verification of material property values and units for consistency.

Applied Loads: [13] [16]

It includes verification of load value, direction of load. This can be verified by reading .bdf file under ‘load resultant’ as shown in figure 4.10, for WLL_01 applied loads are selfweight of beam and the engine weight, total load is 90715.11 N in -ve Z-direction.

SUBCASE/	LOAD	X1			X2			X3		
ID	TYPE	T1	T2	T3	R1	R2	R3	S1	S2	S3
1	FX	-2.596685E-18	----	----	2.242841E-14	----	----	-1.644217E-13	----	----
	FY	----	-4.321184E-18	----	3.660428E+08	----	----	----	----	----
	FZ	----	----	-9.071311E+04	-2.721391E+08	----	----	----	----	----
	MX	----	----	----	0.000000E+00	----	----	----	----	----
	MY	----	----	----	0.000000E+00	----	----	----	----	----
	MZ	----	----	----	0.000000E+00	----	----	----	----	----
	TOTALS	-2.596685E-18	-4.321184E-18	-9.071311E+04	-2.721391E+08	3.660428E+08	-8.998631E-13	----	----	----

Figure 12: Applied Loads

Free edge checks:

For a real life FE model, free edged should match with geometry outer/free edges. Additional free edges are an indication of unconnected nodes. It highlights element disconnects at interfacing nodes. 1D elements always appear as free edges. Erase them to identify the cracks to be eliminated. Care should be exercised if intentional disconnects are modelled.

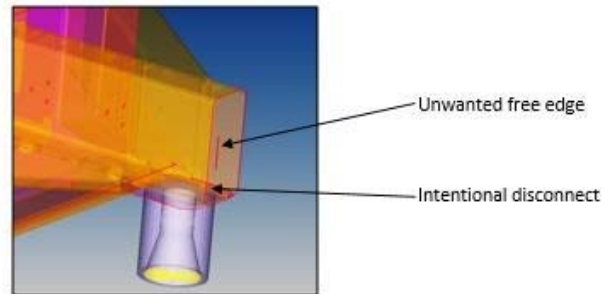

Figure 13: Free Edges

Shrink plot:

Missing elements, collapsed elements can be detected in this plot by visual examination as shown in below figure 4.12 two unwanted elements are appearing in shell elements, which creates an error and analysis run stops with fatal errors.

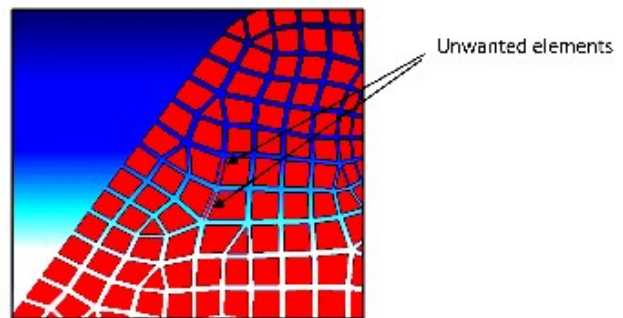

Figure 14 Shrink Plot

Direction Normals:

It is the verification of the consistency of normals of the elements. It also ensures consistent element to the coordinate systems. Shell element normal helps in viewing top or bottom side stresses. Every element has elemental (or local) co-ordinate system. Shell normal is direction of elemental normal. Correct shell normal alignment. FEA software provide special command for consistent shell normal.

Check Mass (Actual mass v/s FE model mass):

[6] FE model mass is compared with actual UA model. Difference means missing or additional components or improper material or physical properties.

The difference between masses may be due to weld connections.

Units:

The solver NASTRAN don't have its own unit system. So consistency of units given to each variables is very important.

The unit system used for this analysis is as shown in table 1

Table 1: Input unit system

S. N.	Parameter	Units
1	Length	mm
2	Mass	Tonnes
3	Force	Newtons
4	Density	Tonnes/mm ³
5	Young's Modulus	Newtons/mm ²
6	Gravitational Acceleration	mm/s ²

With this input unit system units of output parameters i.e. for stress and displacement are MPa and mm respectively.

Boundary Conditions:

This is most important input for any type of analysis. Boundary condition must be studied and applied correctly. These are applied in terms of dof at nodes points.

Coincident nodes:

Remove coincident nodes by equivalence action. Tolerance value is available in equivalence option. If model has intentional duplicates. Identify them and isolate from equivalence action e.g. CBUSH element

Duplicate Elements:

Mistakes during operations like reflect, translate etc. results in duplicate elements. These extra duplicate elements do not cause error in analysis but increase stiffness of the model and results in lesser displacement and stress. Identify elements with the same connectivity and remove unwanted. The planned duplicate elements shall be retained and confirmed in the report.

Free-free run or dummy linear static analysis:

Free-free run is performed on existing UA model. 6 rigid modes indicate all the parts in the assembly are properly connected to each other

Thus the meshing is completed and engine weight and mass of removed components are applied as concentrated masses. Output requests for stress and displacement plot are given. Meshed model is exported to NASTRAN for analysis.

V. CONCLUSION

- 1) 1D elements can be used for bolts and washers, and to apply the loads on common areas. For thin sheets, tubes, and plates 2D elements should be used and the components for which all three dimensions are comparable should be meshed with 3D elements.
- 2) Rigid element RBE2 distributes the load on dependent nodes according to their locations.
- 3) Sliding and line contacts can be created by using rigid elements with the proper dof applied to them.
- 4) Selection between rigids and beam elements plays very important role for stress distribution in the members. So at critical areas and for special purpose pins, and locators beam elements must be used rather than rigids.
- 5) At some location thumb rules for selection of element types has some exceptions, for reinforcements location solid elements are preferred than shell elements.
- 6) HyperMesh tool have many sub-tools for meshing quality assurance, and those can be used very effectively for element quality check, element geometry and material property check, free edge check, direction normals and mass check, and coincident nodes check.
- 7) If the model is perfectly modelled, then for static analysis, frequencies of first six normal modes should be zero. This ensures that there is no mechanism in the model.

REFERENCES

- [1] Rachakulla Saikrishna, P V Anil Kumar, "Design and buckling strength evaluation of a lifting beam for 350 tonnes through FEA", International Journal of Engineering Research and Science & Technology, vol.3 No. 4, November 2014.
- [2] Jin yi-min, "Analysis and Evaluation of Minivan Body Structure Finite Element Method", 2nd Worldwide Automotive Conference, Vol. 1 No. 05, 2002
- [3] J.Fang, C.Hoff, B.Holman, F.Mueller, D.Wallerstein, "Simulation of welding using MSC.NASTRAN", 2nd Worldwide Automotive Conference, Vol. 1 No. 63, 2002
- [4] Adrian Viisoreanu, Kris Wadolkowski, "Particularities of single shear pin joints modelling for MSC/NASTRAN", Americans User's Conference, No. 3898, 1998.
- [5] John McCullough, Lance Proctor, "Local analysis of fastener holes using the linear gap technology of MSC/NASTRAN", MSC Aerospace user's conference, No. 5799, 1999.
- [6] .T. Chung, L.L. Kahre, "A general procedure for finite element model check and model identification", World User's Conference, No. 3895, 1995
- [7] Prakash E. Mohansundaram, "Structural analysis of a heavy lift vessel", Master's Thesis at University of Stuttgart, Germany, July 2009
- [8] John E. Schiermeier, Jerrold M. Houser, Mohamad A. Aminpour, W. Jefferson Stroud, "The Application of Interface Element to Dissimilar Meshes in Global/Local Analysis", The 1996 MSC World User's Conference, California 1996
- [9] John E. Schiermeier, Jerrold M. Houser, Mohamad A. Aminpour, W. Jefferson Stroud, "Interface Element in Global/Local Analysis – Part 2: Surface Interface Element", The 1996 MSC World User's Conference, California 1999
- [10] John E. Schiermeier, Rajendra K. Kansakar, Jonathan B. Ransom, Mohamad A. Aminpour, W. Jefferson Stroud, Interface Element in Global/Local Analysis – Part 3: Shell-to-Solid Transition, The 1996 MSC World User's Conference, California 1999
- [11] Nitin Gokhale, Sanjay Deshpande, Sanjeev Bedekar, Anand Thite, "Practical Finite Element Analysis", Finite to Infinite Publication Pune 2008.
- [12] T.R. Chandrupatla & A.D. Belegundu, 4th edition, "Introduction to Finite Elements in Engineering", Pearson Higher Education, Inc., Upper Saddle River, NJ 07458
- [13] MSC Nastran 2001, Quick Reference Guide
- [14] European structural steel standard EN 10025 : 2004
- [15] www.altairhyperworks.com
- [16] www.mscsoftware.com