



# PERFORMANCE EVALUATION OF MAXIMUM POWERPOINT TRACKING (MPPT) MICROCONTROLLER BASED SMART HOME SOLAR ENERGY CHARGER

S.Saminathan<sup>1</sup>, E.Sangaralingam<sup>2</sup>, S.Sankaran<sup>3</sup>, E.Vadavengadam<sup>4</sup>, R.Elangovan<sup>5</sup>  
Department of EEE, PRIST University, Thanjavur.

## ABSTRACT

A charge controller that includes an input interface that receives input DC electrical signals. A converter section converts the input DC electrical signals to output DC electrical signals. Control means is operably coupled to the converter section. The control means includes means for operating the converter section at an estimated maximum power point of the input DC electrical signals. The estimated maximum power point is derived by a novel control scheme that quickly adapts to changing conditions and thus affords optimum energy harvest from the source and improved energy conversion efficiencies. Photovoltaic electricity generation offers the benefits of: clean, non-polluting energy generation, production of energy close to the consumer (in case of DPGS), the very little or no maintenance requirement, and of having a very long lifetime. Due to these advantages, today, the photovoltaic is one of the fastest growing markets in the world. However, PV power is still considered to be expensive, and the cost reduction of PV systems is subject to extensive research. From the point of view of power electronics, this goal can be approached by maximizing the energy output of a given PV array. The inverter should ensure the highest possible conversion efficiency, while the requirement for the MPPT control is to operate the PV array at the optimum working point (MPP) in all environmental conditions. A considerable amount of PV capacity today is installed in temperate climate zones. Although modern PV inverters' MPPT efficiency is very high in stable conditions, further research is needed to achieve similar performance levels in

variable conditions. The primary objective of this project is to build efficient solar charger that will recharge the battery properly with minimum loss with overcoming the voltage variation in solar panel. This charge controller will protect the battery from overcharge and deep discharge. It will maximize the solar generation by MPPT method.

The proposed system is to present a novel cost effective and efficient microcontroller based MPPT system for solar photovoltaic system to ensure the maximum power point operation at all changing Environmental condition. The P&O MPPT algorithm is used to control the maximum transfer power from a PV panel. This algorithm is executed by MPPT Controller using LM324

**KEYWORDS:** charge controller, DC, AC, PWM, MPPT, SHS, MPPT (Maximum power point tracking), PV (Solar photovoltaic), P&O (Perturb and observe), Optocoupler.

## 1. INTRODUCTION

Photovoltaic production becomes double every two years, increasing by an average of 48 percent each year since 2002. For this reason it becomes the world's fastest-growing energy technology [1]. Photovoltaic efficiency is very important for solar application. Photo-voltaic (PV) panels (sometimes referred to as photovoltaic modules) produce current at a specific voltage depending on the amount of solar radiation hitting the cells of the panel. The theoretical maximum amount of power from the sun at the earth's surface is about 1 KW per square meter at the equator on a clear day. To make the electrical power useful when the sun is not available, it must be stored,

typically in batteries. The nature of the PV panels is that they have a specific Voltage × Current curve that changes with the temperature and on the amount of sunlight or the angle at which the sun strikes the panel. Higher temperatures lower the voltage and more sunlight increases the output current. Distributed photovoltaic generation, in the form of roof-top domestic systems, is being installed at an increasing scale [2-4]. Significant power quality issues, especially voltage rise and voltage unbalance have been widely studied [5, 6].

Higher penetrations or renewable generation within the distribution network can be achieved by the addition of intelligent control, storage or regulatory devices, [7].

In this case charge controller plays a vital role to protect the battery [8]. A series charge controller disables further current flow into batteries when they are full. A shunt charge controller diverts excess electricity to an auxiliary or "shunt" load, such as an electric water heater, when batteries are full [8, 9].

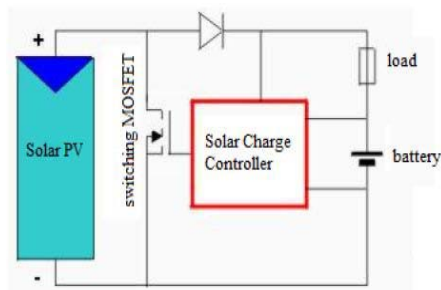

Figure 1:(a)SHS with series controller[8]  
controller[8]

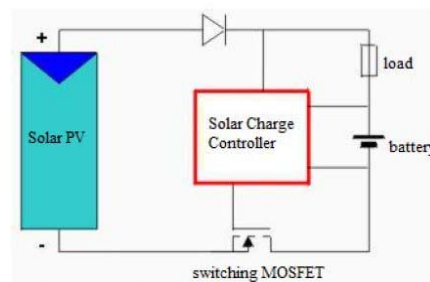

Figure 1:(b)SHS with shunt

Charge controller has been regarded as one of the important devices in stand-alone photovoltaic systems to prevent the battery from damage due to over-charging and over-discharging. Besides that, the unstable voltage from photovoltaic systems may spoil the load.

Studies show that the life time of the battery is degraded without using charge controller. Therefore, a charge controller should be designed to prolong the battery's life time and stabilize the voltage from photovoltaic panel.



Figure1: (c) Basic image of controller and battery wiring

## 2. INVENTION REVIEW

### a) Field of the Invention

This invention relates broadly to charge controllers that perform DC-DC power conversion. More particularly, this invention relates to charge controllers for solar applications, including converting DC electrical energy provided by photo-voltaic means for charging electrochemical batteries and for direct output.

### b) State of the Art

Photo-voltaic (PV) panels (sometimes referred to as photovoltaic modules) produce current at a specific voltage depending on the amount of solar radiation hitting the cells of the panel. The theoretical maximum amount of power from the sun at the earth's surface is about 1 KW per square meter at the equator on a clear day. To make the electrical power useful when the sun is not available, it must be stored,

typically in batteries. The nature of the PV panels is that they have a specific Voltage×Current curve that changes with the temperature and on the amount of sunlight or the angle at which the sun strikes the panel. Higher temperatures lower the voltage and more sunlight increases the output current.

For increased system efficiency, it is desirable to operate PV panels at the voltage and current levels

that produce the peak power, which is referred to as the Maximum Power Point. Loads such as batteries, on the other hand, have a need for voltage and current which is independent and often different from what the PV panel is producing. A charge controller (which can also be referred to as a charge regulator or regulator) is connected between the PV panel(s) and the batteries or load in order to deal with this mismatch. The charge controller performs DC-DC power conversion typically utilizing Pulse Width Modulation (PWM) control of the electrical energy produced by the PV panels in order to transform such energy into a suitable form. For example, for battery charging applications, the PWM control is used to adjust the voltage levels and current levels output the battery. More particularly, as the battery reaches full charge, the PWM control is used to limit the voltage level supplied to the battery such a not to the harm the battery (i.e., inhibiting the boiling of the electrolyte of the battery, which can destroy the battery). Early charge controllers were only able to reduce the amount of voltage from the PV panels if too high for the batteries. Since the voltage from the PV panels would be lower at high temperatures, the PV panels had to be oversized to ensure that the minimum voltage at high temperatures would be at least as high as the battery to be charged plus voltage headroom enough to force current into the battery. At any temperature lower than the maximum, the excess voltage from the PV panels would have to be discarded by the charge controllers. Because PV panels are the most expensive component of the system, the need for extra (or larger) PV panels negatively impacted the cost-effectiveness of such PV power systems.

Newer and more efficient charger controllers have emerged that provide a better match between the PV panels and their load. Their goal is to use all the power from the PV panel(s) regardless of the voltage and current at any amount of insulation or at any temperature.

The newer charge controllers employ a DC to DC converter section that is adapted to dynamically charge the battery (or to directly power a load) at the exact voltage and current that is most appropriate for that battery (or load). Although the newer charge controllers provide improved system efficiencies relative to the older models, they too often suffer from several shortcomings. More particularly, the charge controllers are slow to adapt to changing conditions of the PV panel(s) over the course of any given day, including low light conditions in the morning, evening and during cloud cover and also temperature changes sometimes associated with the changes in insolation. The edges of clouds create particularly issues because they cause a rapid change in lighting which may be followed by a relatively rapid change in temperature. Because they do not quickly adapt to changing conditions, the charge controllers have limited efficiency, which results in the need for extra (or larger) PV panels to be used for a given power output and high costs.

## 2.1. MAXIMUM POWER POINT TRACKING

The perturbation leads to an increase (decrease) in array power, the subsequent perturbation is made in the same (opposite) direction. In this manner, the peak power tracker continuously seeks the peak power condition. Moreover, in rapidly changing atmospheric conditions, the MPPT takes considerable time to track the MPP[10].

## 2.2. DC-DC Converter

The boost converter is used to truly track the maximum power point rather than maximizing the voltage[11]. The basic circuit of the boost converter designed and developed is shown in Figure 2. It is well known that the relationship between the input voltage and the output voltage of the boost converter is given by the relationship (1).

$$V_{out} = V_{pv} / (1 - \alpha) \quad (1)$$

Where,  $\alpha = t_{on} / T$  is defined as the converter duty cycle. This means that the converter output voltage can be simply controlled by the variation of the duty cycle.

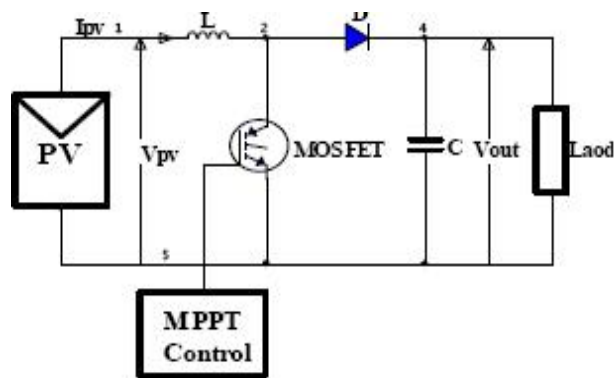

**Figure 2: Boost converter**

The duty cycle  $\alpha$  is changed continuously in order to track the maximum power point of the photovoltaic. The inductor value,  $L$ , required to operate the converter in the continuous conduction mode is calculated such that the peak inductor current at maximum output power does not exceed the power switch current rating. Hence,  $L$  is calculated as

$$L \geq V_{pv} \alpha / f \Delta I_{pv} \quad (2)$$

Where,  $f = 1/T$  is the switching frequency,  $\alpha$  is the duty cycle at maximum converter output power,  $V_{pv}$  the input voltage and  $\Delta I_{pv}$  is the peak-to-peak inductor ripple current. The choice of the converter inductor value and the switching frequency is a compromise between converter efficiency, cost, power capability and weight. The output capacitor value calculated to give the desired peak-to-peak output voltage ripple.

### 3. METHODOLOGY

#### 3.1. MICROCONTROLLER BASED CHARGE CONTROLLER

Microcontroller based charge controller design is feasible for performing complex task. PIC16F877A microcontroller used in this charge controller is the central of coordinating all system's activity. It is designed in 40 pin DIP package (Dual In Line Package) and it is the member from microcontroller 8-bit "Reduced Instruction Set Computer Central Processing Unit family" (RISC CPU) which implement the Harvard architecture by separating code and data spaces. Here, PIC16F877A microcontroller is used to control the operation of charging control and data acquisition task in this project. PIC16F877A contains 5 I/O ports which are

suitable for the development of the charge controller. Port A is used to perform the analog to digital conversion which is used in input parts like temperature sensing circuit, battery voltage sensing circuit and current sensing circuit. Port B is used to interface with the LCD module whereas port C controls disconnect or reconnect operations for photovoltaic panel or load and also triggering the buzzer and generating the PWM signal to control the boost converter. Port D is used as input part for switching control and as output part for LED indicator. Block diagram of charge controller.

They are used to detect the voltage and current of the circuit and send the data to the PIC microcontroller to analyze and PIC microcontroller will operate according to the program written inside its memory. For the output part, it consists panel-battery connect/disconnect circuit, sources load connect/disconnect circuit, LCD module, PWM signal low voltage warning circuit, status indicator circuit. The 20MHz crystal is used as clock frequency of the microcontroller. The power of microcontroller is used from solar with 78L05 voltage regulator. Battery voltage is sensed across a potential divider which dropped it to less than 5V and a LED is used to give warning when this was low. An LM35 temperature sensor sensed the ambient temperature. Two power MOSFETs (IRF540) are used as solid-state switch for the panel-battery line and battery-load line. LEDs of differing colors are used to display the system status. The third power MOSFET is derived as boost converter switching transited by PWM signal that is came from microcontroller.

#### 3.2 DATA BASE

It is therefore an object of the invention to provide a charge controller that quickly adapts to changing conditions and thus affords improved

energy conversion efficiencies. It is another object of the invention to provide such a charge controller which can be adapted for use with a wide range of PV panels. It is a further object of the invention to provide such a charge controller which can be adapted for use with a wide range of DC loads including batteries for energy storage and DC-AC inverters for direct output. In accord with these objects, which will be discussed in detail below, a charge controller is provided that includes an input interface that receives input DC electrical signals. A converter section converts the input DC electrical signals to output DC electrical signals. Control means is operably coupled to the converter section. The control means includes means for operating the converter section at an estimated maximum power point of the input DC electrical signals. The estimated maximum power point is derived by a control scheme that includes the following operations:

- i) storing an input voltage level corresponding to the estimated maximum power point;

- ii) varying the input voltage of the input DC electrical signals over a sequence of sample points from a first voltage level to a second voltage level, and deriving and storing an output current value of the output DC electrical signals at each sample point;
- iii) selecting the maximum output current value from the output current values stored in ii), and identifying the particular input voltage level corresponding thereto; and
- iv) varying the input voltage of the input DC electrical signals over a sequence of sample points from the second voltage level to the particular input voltage level identified in iii); and

In the absorption charging mode, the control means regulates the output voltage of the output DC electrical signals such that it is maintained at a predetermined absorption charging mode voltage level. Additional objects and advantages of the invention will become apparent to those skilled in the art upon reference to the detailed description taken in conjunction with the provided figures.

3.3. DESCRIPTION OF THE DRAWINGS

FIG. 1

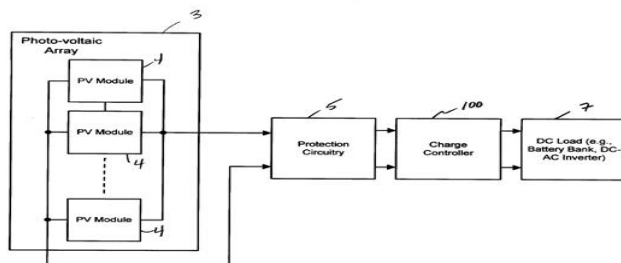

Figure 3: block diagram of a solar electric generator system in which the present invention can be embodied

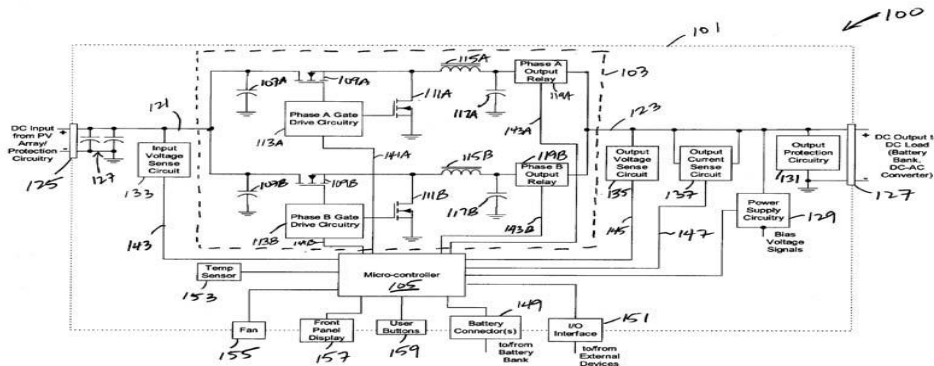

Figure 4: high-level schematic diagram of a charge controller in accordance with the present invention, which can be used as part of the solar electric generator system of FIG. 1 to convert the DC electrical signals generated by the photovoltaic array into a DC form suitable for supply to the DC load.

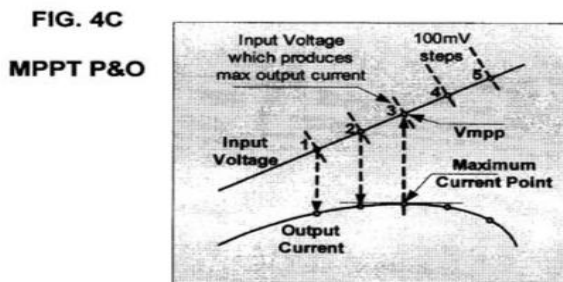
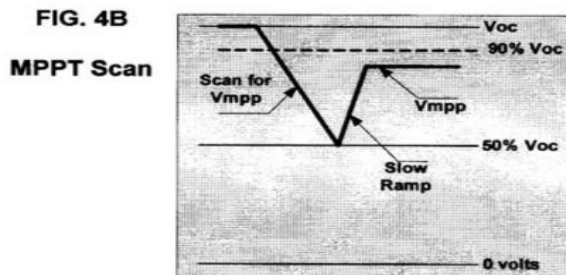
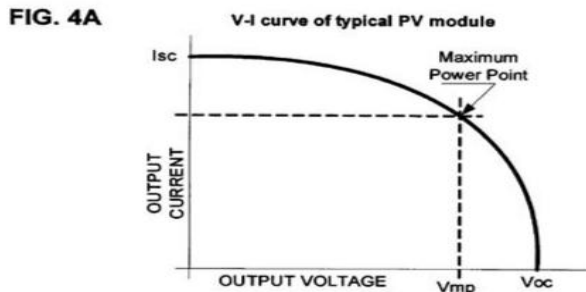

Figure 4a: Pictorial illustration of the I-V curve of a typical photovoltaic module;  
 Figure 4b: Pictorial illustration of exemplary scanning operations that are carried out by the charge controller of FIG. 2 for deriving an input voltage for estimated maximum power point conversion operations in accordance with the present invention;  
 Figure 4c: Pictorial illustration of exemplary perturbation and observation operations that carried out by the charge controller of FIG. 2 for deriving the input voltage for estimated maximum power point conversion operations in accordance with the present invention;

## 5. PERFORMANCE EVALUATION

### 5.1 Pulse-Width Modulation

#### Charging Method

With pulse-width modulation (PWM) a voltage or current signal is switched on and off with a variable duty cycle,  $\beta$ . The average output voltage is  $\beta V_s$ , where  $\beta = T_{on} / (T_{on} + T_{off})$ ,  $T_{on}$  is the on-time and  $T_{off}$  is the off-time of the switch and  $V_s$  is the supply voltage. PWM is produced by a power MOSFET transistor switched through channel RC2 of the microcontroller via a transistor. Charging from the lower set point take place at full panel current ( $\beta = 1$ ). When normal gassing occurs,  $\beta$

is progressively decreased almost to zero until the upper set point is reached.

Software is crucial element in the development of solar charge controller. The main objective of the software development is to give instruction, control and coordinate the PIC16F877A to execute various tasks. In this case, mikroC code is written for the software development of solar charge controller. Microcontroller based designs are able to provide more intelligent control with the same device simply by changing the program parameters and/ or adding more sensors and by matching it to the various stages of charge of the battery. If the surrounding temperature is higher

than 70°C, the system will be turn off. Figure 3 illustrates the flow chart for the software development of charge controller. The complete

schematic diagram of the proposed charge controller is shown in figure 4.

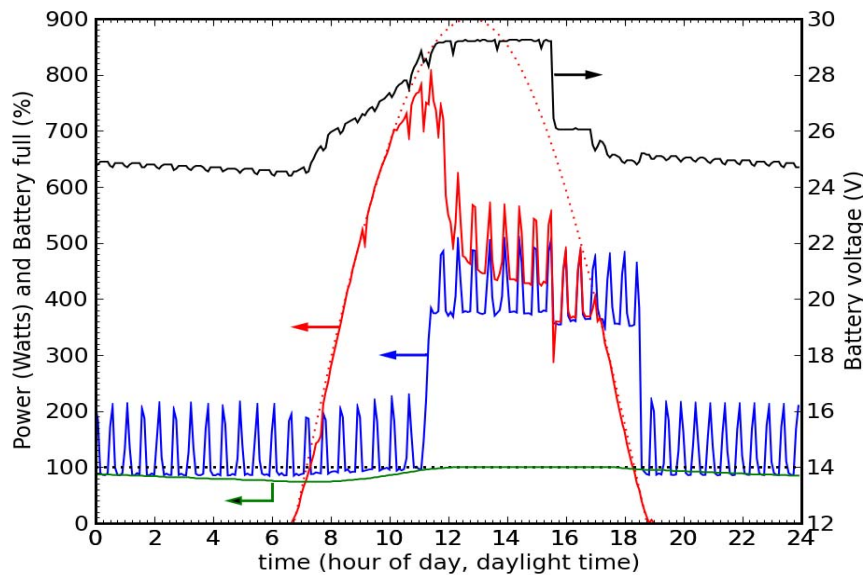

**Figure 5: Evaluation Graph**

## 6. CONCLUSION

It is preferably that the control operations be realized as a program of instructions that are loaded into the firmware of the microcontroller or other programmed logic device. Furthermore, while the embodiments described above utilize field effect transistors as switching devices, it will be understood that other switching devices such as IGBT insulated gate bipolar transistors can be similarly used. In addition, while particular solar applications have been disclosed, it will be understood that the charge controller described herein can be adapted for other energy conversion applications such as wind energy harvesting, wave-energy harvesting, hydroelectric energy harvesting, thermoelectric energy harvesting, etc. It will therefore be appreciated by those skilled in the art that yet other modifications could be made to the provided invention without deviating from its spirit and scope as claimed.

The PV output power delivered to a load can be maximized using MPPT control systems, which consist of a power conditioner to interface the PV output to the load, and a control unit, which drives the power conditioner such that it extracts the maximum power from a PV array. The system consists of a high-efficiency, Boost-type dc/dc converter and a microcontroller-based unit which controls the dc/dc converter directly from the PV array output power measurements.

PIC microcontrollers are easy to be used with mikro C code and there are many types of PIC microcontroller in the market that can perform better than PIC16F877A. Therefore, there is a potential for further research and future work on application of high end PIC microcontroller to further improve the performance of charge controller with some cost effective designs.

## REFERENCES

1. G. M. Sharif, S. Mohaiminul Islam, and K. M. Salim, "Design & construction of microcontroller based maximum power point PWM charge controller for photovoltaic application," in *Developments in Renewable Energy Technology (ICDRET), 2009 1st International Conference on the*, 2009, pp. 1-4.
2. M. Alam, K. Muttaqi, and D. Sutanto, "A comprehensive assessment tool for solar PV impacts on low voltage three phase distribution networks," in *Developments in Renewable Energy Technology (ICDRET), 2012 2nd International Conference on the*, 2012, pp. 1-5.
3. F. Shahnian, R. Majumder, A. Ghosh, G. Ledwich, and F. Zare, "Sensitivity analysis of voltage imbalance in distribution networks with rooftop PVs," in *Power and Energy Society General Meeting, 2010 IEEE*, 2010, pp. 1-8.

4. R. Yan and T. K. Saha, "Voltage variation sensitivity analysis for unbalanced distribution networks due to photovoltaic power fluctuations," *Power Systems, IEEE Transactions on*, vol. 27, pp. 1078-1089, 2012.
5. H. Pezeshki, P. Wolfs, and M. Johnson, "Multi-agent systems for modeling high penetration photovoltaic system impacts in distribution networks," in *Innovative Smart Grid Technologies Asia (ISGT), 2011 IEEE PES*, 2011, pp. 1-8.
6. X. Liu, A. Aichhorn, L. Liu, and H. Li, "Coordinated control of distributed energy storage system with tap changer transformers for voltage rise mitigation under high photovoltaic penetration," *Smart Grid, IEEE Transactions on*, vol. 3, pp. 897-906, 2012.
7. N. Jayasekara and P. Wolfs, "A hybrid approach based on GA and direct search for periodic optimization of finely distributed storage," in *Innovative Smart Grid Technologies Asia (ISGT), 2011 IEEE PES*, 2011, pp. 1-8.
8. I. A. Karim, A. A. Siam, N. A. Mamun, I. Parveen, and S. S. Sharmi, "DESIGN OF A SOLAR CHARGE CONTROLLER FOR A 100 WP SOLAR PV SYSTEM," in *International Journal of Engineering Research and Technology*, 2013.
9. E. M. Barber and J. Provey, *Convert your home to solar energy*: Taunton Press, 2010.
10. Sree Manju B, Ramaprabha R and Mathur B.L, "Design and Modeling of Standalone Solar Photovoltaic Charging System", *International Journal of Computer Applications* (0975 – 8887), Volume 18–No.2, March 2011.
11. Wikipedia Contributors: Solar Energy, Wikipedia, the Free Encyclopedia, 23, August, 2012.