



FULLY AUTOMATED VALET CAR PARKING SYSTEM AND UNIQUE VEHICLE EXIT NUMBER

T.Joby Titus¹, V.S.Sanjana Devi², B.Saranya³, M.Pravin⁴

^{1,4}Assistant Professor (Sr.Grade), ³ Assistant Professor,
Department of Electronics and Communication Engineering,
Sri Ramakrishna Institute of Technology, Coimbatore, India.

²Assistant Professor, Department of Electrical and Electronics Engineering,
Sri Krishna College of Technology, Coimbatore, India

Abstract

Due to a rapid increase in the number of vehicles, the need for parking spaces is on rise in smart cities. It is important to park the cars in close proximity to avoid traffic congestion and use a parking area efficiently. Recent car parking management systems utilize human personnel to find free parking areas or use a video based system that collects the information in the form of images and tracks available parking slots. This new model proposes a novel low cost automated car parking system in which human involvement is eliminated. The number of vacant parking slots is indicated at the entrance of parking area as well as to the vehicle owner using GSM module. The vehicle owner mobile number is linked to automated valet parking system using RFID tag. A unique RFID tag is linked with the mobile number of driver/owner of vehicle. The driver has to park the car in the specified slot near entrance and the person can leave the vehicle without searching for a vacant space thus reducing the time for parking and making an efficient use of available space. The robotic module places the vehicle in the vacant slot. The parking slot level location information is send to the driver. The driver has to dial to the valet common linked number and the chosen vehicle would be moved to exit location slot. The vehicle arrival location to the exit slot is also indicated to the mobile number of vehicle owner. The result suggests that it is a novel robust system and can be

implemented in real time with an option to increase the number of parking slots as required.

Index Terms: RFID, GSM, DC Motor, LCD.

I. INTRODUCTION

Parking space has always been a problem since the invention of vehicles. At the start, people parked their car manually. Then at fancy restaurants and parties men were used to park cars, this is referred as valet parking. Due to advancement in technology human operated robots were used to park cars in slots. Shortage of parking spaces led to multistory parking areas. Conventional systems had a runway in which the user has drive all the way and park the car. To save space these runways were eliminated and robotic arms were used to pick and place the car in those slots. They were controlled by humans. Then it was automated. Tokens were given to users when they leave. They have to return them to get back their cars. Then video based systems were used to park the cars in those slots. This system uses high resolution cameras to acquire real time images of the slots and free slots are identified with the help of image processing. The robotic arm is made to function based on these results. Human operated robotic arms were also used to place the cars in those desired slots. Here the human identifies the free slot and controls the robotic arms with the help of a console. The arm is controlled and moved to pick the car and place it in a desired slot. These parking systems must not be complex for the user. It should be user

friendly only then they can implement with greater efficiency. The backend processes should not affect the user at any cost. The safety of the cars is ultimate. Cars should be handled with care and there should be no chances for error.

Due to a rapid increase in the number of vehicles, the need for parking spaces is on rise in smart cities. It is important to park the cars in close proximity to avoid traffic congestion and use a parking area efficiently. Recent car parking management systems utilize human personnel to find available parking areas or use a video based system that collects the information in the form of images and tracks available parking slots. This new system proposes a novel automated car parking system in which human involvement is eliminated. The number of vacant parking slots is indicated at the entrance of parking area as well as to the vehicle owner using GSM module. The vehicle owner mobile number is linked to automated valet parking system using RFID tag. A unique RFID tag is linked with the mobile number of driver/owner of vehicle. The driver has to park the car in the specified slot near entrance and the person can leave the vehicle without searching for a vacant space thus reducing the time for parking and making an efficient use of available space. The robotic module place the vehicle in the vacant slot and the parking slot level location information is send to the driver. The driver has to dial to the valet common linked number and the chosen vehicle would be moved to exit location slot. The vehicle arrival location to the exit slot is also indicated to vehicle owner mobile number. The results suggest that it is a novel robust system and can be implemented in real time with an option to increase the number of parking slots as required. All APS take advantage of a common concept to decrease the area of parking spaces - removing the driver and passengers from the car before it is parked. With either fully automated or semi-automated APS, the car is driven up to an entry point to the APS and the driver and passengers exit the car. The car is then moved automatically or semi-automatically (with some attendant action required) to its parking space. Fully automated parking systems operate much like robotic valet parking. The driver drives the

car into an APS entry (transfer) area. The driver and all passengers exit the car. The driver uses an automated terminal nearby for payment and receipt of a ticket. When driver and passengers have left the entry area, the mechanical system lifts the car and transports it to a pre-determined parking space in the system. More sophisticated fully automated APS will obtain the dimensions of cars on entry in order to place them in the smallest available parking space. The driver retrieves a car by inserting a ticket or code into an automated terminal.

The APS lifts the car from its parking space and delivers it to an exit area. Most often, the retrieved car has been oriented to eliminate the need for the driver to back out. Fully automated APS theoretically eliminate the need for parking attendants. Semi-automated APS also use a mechanical system of some type to move a car to its parking space, however putting the car into and/or the operation of the system requires some action by an attendant or the driver. The choice between fully and semi-automated APS is often a matter of space and cost, however large capacity (> 100 cars) tend to be fully automated. By virtue of their relatively smaller volume and mechanized parking systems, APS are often used in locations where a multi-story parking garage would be too large, too costly or impractical. Examples of such applications include, under or inside existing or new structures, between existing structures and in irregularly shaped areas. APS can also be applied in situations similar to multi-storage parking garages such as freestanding above ground, under buildings above grade and under buildings below grade.

The token based system and other existing systems have lot of disadvantages. The token system requires a human to check the token and identify the car. And the user has to keep his token safe in order to get his car back. When it comes to video based system, Low light conditions may cause troubles and video based system is not much efficient. Chance for error is high and human supervision is required. The other system where human operated arm is used also has disadvantages. Human errors are unpredictable and could happen anytime. In this proposed system no human involvement is required and all these errors could be avoided.

The Arduino microcontroller along with GSM technology is used to automate all these process.

II. PROCEDURE FOR PAPER SUBMISSION

Fully automated parking systems operate much like robotic valet parking. The driver drives the car into an APS entry (transfer) area. The driver and all passengers exit the car. The driver uses an automated terminal nearby for payment and receipt of a ticket. When driver and passengers have left the entry area, the mechanical system lifts the car and transports it to a pre-determined parking space in the system. More sophisticated fully automated APS will obtain the dimensions of cars on entry in order to place them in the smallest available parking space.

The presence of car is detected with the help of sensor. Owner’s mobile number is detected with the help of RFID tag present in the car. RFID reader is present at the entrance of the parking. Controller checks for free space and places the car in the slot and the corresponding slot number is sent as message to the owner .When the user is about to leave he has to call a registered mobile number. The GSM module detects the incoming mobile number and locates the car. The controller then commands the arm to bring the car to the exit slot.

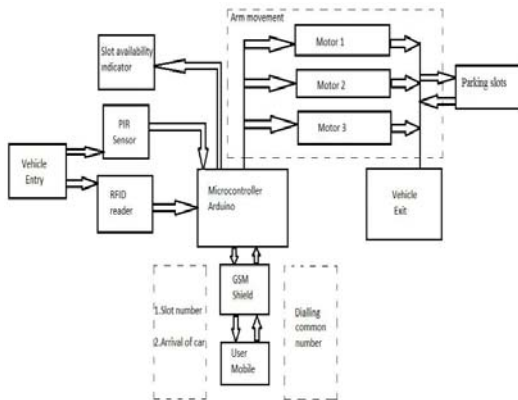

Figure 1 Block diagram of proposed system

Figure 1 shows that the microcontroller acts as the heart of the system. The entry and id of the car are detected and given to the controller. The controller checks the slots and places it. And based on GSM input the position of the car is located and arm movement is done to get the car back. The components used here are PIR sensor, RFID reader, LCD display, Arduino as

microcontroller, GSM SIM900A and three DC motors for Arm movement.

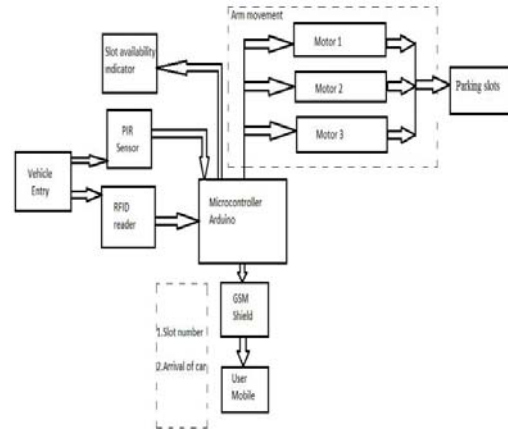

Figure 2 Block diagram for vehicle entry module

This module explains the first part i.e, finding free slots and placing the car. At the start, the arrival of car is detected with the help of PIR sensor. PIR sensor gives an output 1 when a movement is detected in its field. It is read by the arduino which in turn triggers the RFID reader to read the RFID tag present in the car. The information from RFID tag identifies the mobile number of car’s owner from the database. The number thus obtained is saved as a string for further operations. Now the controller searches for free slots from an array of slots. The slots are assigned virtually in the controller. Each slot is declared as a string. When a slot is free the string corresponding to the slot is set as ‘0’ and when a car is to be placed at that slot, the string value is replaced with the owner’s mobile number. If the slot has anything other than zero that means the slot is occupied. After checking the number of free slots and is displayed in the slot availability indicator. If free slot is available the owner parks the car at the zero position and leaves.

Arm movement to each slot is functioned based on free slots and when a free slot is detected that particular function is called. The controller commands the arm to pick the arm from zero position and place at the free slot. Arm movements are done with the help of DC motors. DC motors are controlled driver ICs LM293D. Using belts and bearings the arm in moved in all three co-ordinates. For efficient usage the arm should be able to move in all three directions. After Parking, an acknowledgement with slot

number is sent as an SMS to the owner with the help of GSM module. The GSM module is set to text mode with the help of 'AT+CMGF=1' command. Number to which the text is to be sent is already there in the string corresponding to the slot. Here the car is placed in the free slot and acknowledgement is sent to the owner.

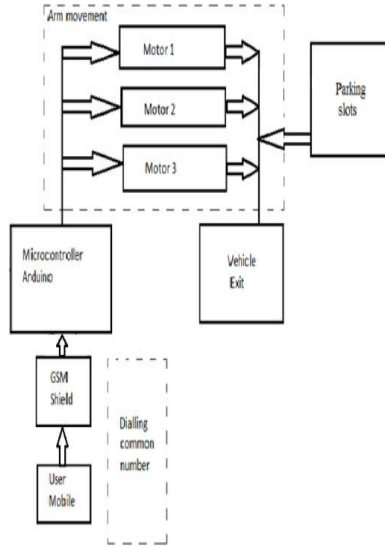

Figure 3 Block diagram for vehicle exit module

Figure shows the block for identifying and getting the car to the exit slot. Here the process starts from GSM module. When the user is about to leave he has to call the number registered in the GSM module. When the call is detected, the incoming call number is detected with the help of 'AT+CLIP=1' command. The incoming number thus obtained is saved as a string. This string is then compared to the string already saved in virtual slots. When the strings match, arm function corresponding to that slot is called. Based on this function the controller commands the arm to get the car to the exit slot.

III. ALGORITHM

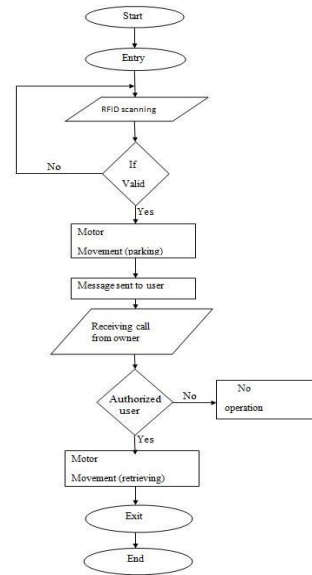

Figure 4 flowchart of proposed system

The above figure shows the flowchart for the entire proposed system. The proposed system is divided into two modules.

- Placing the car
- Getting the car back

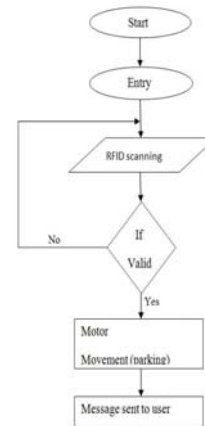

Figure 5 Flowchart for vehicle entry module

Step 1: The car enters the entry slot.

Step 2: The RFID reader reads the tag placed in car.

Step 3: If the tag is valid, motor movement is done and the car is placed in the desired slot

Step 4: An acknowledgement message is sent to the car's owner.

Step 5: If the RFID tag value does not match with the database, then the control moves back to RFID scanning.

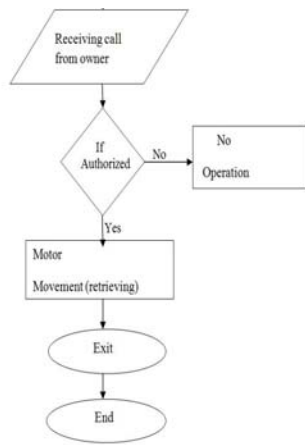

Figure 6 flowchart for vehicle exit module

Step 1 : Owner calls a registered mobile number.

Step 2 : Call is detected with the help of GSM module

Step 3 : If the call is authorized, it checks for the position of the car and desired motor movement is done to retrieve the car.

Step 4 : The car is brought to the exit slot.

Step 5 : If the call is not authorized, no operation is done and control goes back to the GSM and waits for call.

IV. RESULT AND DISCUSSION

This system is created and developed using simple and cost-efficient components. This system is divided into two modules and can be interfaced with the use of wires.

In the first module, a PIR Sensor module is interfaced with Arduino Mega is sensing the arrival of the vehicle. The PIR Sensor Module has three pins: Vcc, Vout and GND. Vout pin of the PIR Sensor is connected to any one of the analog pin of Arduino Uno (A0-A5), the supply is given in the Vcc pin and the GND pin is grounded as shown in the figure.

RFID Reader module reads the RFID tag and sends the tag value to the Arduino and that tag value is linked with the appropriate car owner mobile number. Once the tag is read the car will be parked and the car parked slot number is sent as message to the number which is linked with the tag.

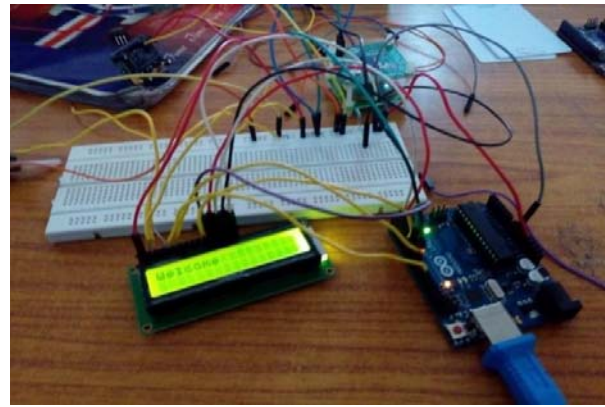

Figure 6 Diagram of interfacing PIR sensor and RFID Module

The available no. of slots will be displayed using 16x2 LCD module when the PIR sensor senses the vehicle entry.

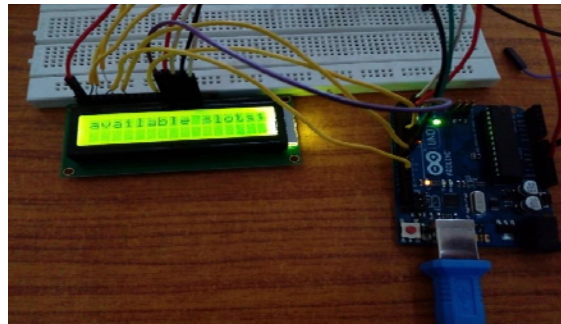

Figure 7 Diagram of interfacing LCD Display

The GSM module is used to send the slot number in which the car has been parked and receive call from the user to get the car back.

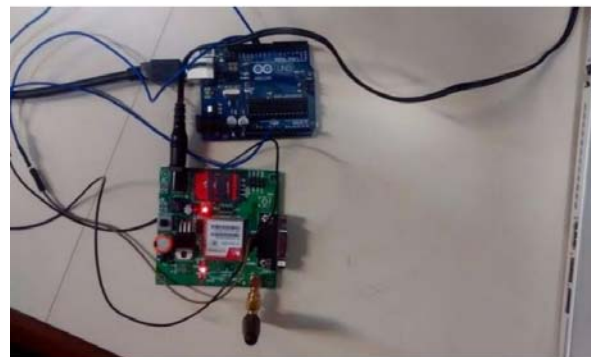

Figure 8 diagram of interfacing GSM Module

In the second module, in order to get the car back, the user has to call to the common registered number which is installed in the GSM module. On calling the controller check the number is from authenticated person or not. If the call is from authenticated person then the robotic arm operates and places the car at the exit slot. If not, the GSM hangs up the incoming call.

The developed module was tested in all the five

steps. All the other units in the system, including sensors, GSM module and power unit are tested and are found to be in working condition. The vehicle owner should leave the car at the entry slot from where the car is taken and parked automatically by the control of Arduino microcontroller 2560. once the vehicle is sensed by PIR sensor and the RFID Reader. After getting user information the car will be allowed to the entry slot.



Figure 9 Diagram of vehicle entry

After the user leaves the car at the entry slot the car is parked. Parking of the car is done by the lifting mechanism of robotic arm which is controlled by the controller. Three motors are used to lift the car from the entry slot to the respective parking slots. Once the car is parked the slot number is sent to the user mobile number through GSM technology.

The below figure shows output message to user sent by GSM module. The slot number is sent to the user mobile number.

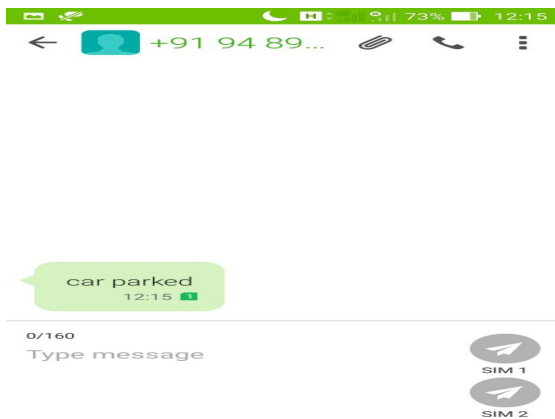

Figure 10 Diagram of message sent to user
When the user wants to get the car from the parking he has to call to the common registered number.

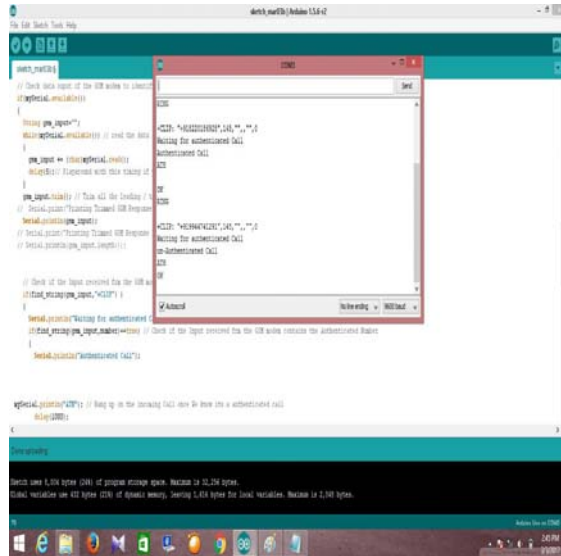

Figure 11 Diagram of output message to user
The above figure shows the message which is sent to user. Since this system is useful for office car parking purpose or for authorized car parking system only authorized user can park the car in their respective slot area. If the user is not authorized the car will not be parked in the slots. If the call is received from the authorized user the car will be moved to the exit slot by the lifting arm mechanism. Else the motor will not be operated.

Once the user called to the common number the robotic arm is activated automatically and the car is lifted from the slots and brought to the exit slot.

V. CONCLUSION

The proposed model has presented a novel automated car parking system using RFID and GSM technology. The RFID reader reads when the car is detected at entry slot. The robotic arm which is operated by arduino identifies the free slots and parks the car in the destined slot. The parking information will be sent to the user through GSM. While returning, the user has to call the registered number to get back his car. Our proposed work can be well suited for real time efficient parking implementation. Future work includes improvising RFID to ZigBee or other protocols. Instead of using database the user itself provides the data about him. If this could be achieved this model can be implemented in all parking areas.

REFERENCES

- [1] Mihai Chirca, Roland Chapuis, Roland Lenain (2015) 'Autonomous Valet Parking System Architecture' IEEE 18th International Conference on Intelligent Transportation Systems, Pg: 2619 - 2624.
- [2] K. Rajasekhar; U. Thirumalai Kumar , G. Vignesh Kumar (2015) 'GPS Based Office Cab Monitoring System using RFID Technology' International journal of scientific engineering and technology research, Pg:2673-2675.
- [3] Daejeon, South Korea, Jeong-Dan Choi, (2013) 'Design and implementation of autonomous vehicle valet parking system' , 16th International IEEE Conference on Intelligent Transportation Systems, Pg:2082 - 2087.
- [4] Anuj K. Nayak, H. C. Akash, Geetha Prakash, (2013) 'Robotic Valet Parking System' India Educators' Conference (THIEC), 2013 Texas Instruments, Pg: 311 – 315.
- [5] Zeydin PALA and Nihat INAN, (2007) 'Smart Parking Applications Using RFID Technology', IEEE Conference on Automation on Robotics, pg 215-219.
- [6] Pala, Z Van, (2007) ' Automation with RFID Technology as an application Parking Lot Circulation Control' (MSc), Yuzuncu Yil University, pg 123-126.