



REVIEW OF SUSPENSION SYSTEM AND EXPERIMENTAL STUDY OF 2 DOF QUARTER-CAR SEMI-ACTIVE SUSPENSION SYSTEM FOR RIDE COMFORT

Pramod A. Yadav¹, Deepak.A.More²

^{1,2}Mechanical Engineering Department, Pune University,

Shri Chhatrapati Shivajiraje College of Engineering and Technology, Dangawadi, Pune, India.

Abstract

This paper presents an experimental analysis of 2 degree-of-freedom quarter-car passive suspension system (2 DOF QC-PSS) and 2 degree-of-freedom Semi-active suspension system (2 DOF QC-S-ASS) (typically composed of a controlled damper and a passive spring) for ride comfort. A quarter-car suspension system consists of the sprung mass, unsprung mass, a suspension spring and damper and a tire spring. A damper with Electro- Rheological (ER) fluid has been considered as one of the most feasible choice for a semi-active suspension system due to its Rheological properties and low cost. Thus this model is modified to a 2 DOF Quarter-car Semiactive Suspension System by placing ER Damper, with its assistant control instrumentation, in between sprung and unsprung masses. The results illustrate considerable improvement in ride comfort above the conventional passive system. The details of the quarter-car model progress with the test set-ups for the passive and hydraulic semi-active suspension systems, suspension elements employed, experimental analysis and results are presented.

Keywords: 2 DOF quarter-car model; Semi-active suspension system; hydraulic actuator; ride comfort

1. Introduction

The main goal of a vehicle's suspension system is to separate the occupants from external terrain included disturbances, while still allowing the average driver to maintain control over the vehicle and drive it safely. The design of vehicle

suspension system always involves a compromise between ride comfort and handling. For good ride comfort a compliant suspension system is normally required, while good handling demands a stiff suspension system to control body roll.

With passive suspension system, the characteristics of the springs and dampers are permanent at the design stage and cannot be changed afterwards. By using controllable springs and dampers, the suspension characteristics can be changed while vehicle is moving. It therefore becomes possible to have soft settings for good ride comfort while travelling on straight lane on good road, as well as changed to hard setting moments later to give good handling when vehicle has to change direction as required for lane changing or even accident avoidance. Setting can also be adjusted based on terrain roughness.

With limited suspension travel available, increased terrain roughness might require an increase in spring stiffness to prevent bump stop contact and therefore improve ride comfort.

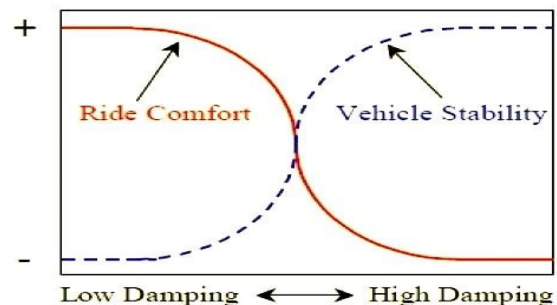

Fig 1 Compromise between Ride and Handling [10]

In order to accomplish the objectives of suspension system i.e. to increase the ride comfort and road handling, there are three parameters to be observed in the simulations. The three parameters are the wheel deflection, dynamic tire load and car body acceleration. For definition of the allowable limits of car body acceleration, there is a frequency domain where human beings are most sensitive to vibration (human sensitivity band 4 ~ 8Hz). It means that for the purpose of improving the ride comfort the car body acceleration gain should be in this range (ISO/DIS 5349 & ISO 2631 – 1978).

The vibration of an on-road vehicle is mainly excited by the roughness of the road surface on which the vehicle travels. Vehicle dynamic analysis has been a hot study topic for many years due to its significant role in ride comfort, vehicle safety and overall vehicle performance. Numbers of papers about the theoretical and experimental study on the dynamic performance of passively and actively suspended road vehicles have been published. The quarter-car model, half-car model and full-vehicle model have been developed with researches related to the dynamic behavior of vehicle and its vibration control.

REVIEW TO SUSPENSION SYSTEM

Generally, there are two categories of vehicle's suspension i.e. conventional suspension and advanced suspension systems. Conventional suspension system refers to the passive suspension system whereas advanced suspension system indicates semi-active suspension and active suspension system.

Passive Suspension System

Conventional suspension system is also known as a passive suspension system consisting of spring and damper mounted at each wheels of the vehicle in parallel. A passive suspension system is one in which the characteristics of the components (springs and dampers) are fixed. These characteristics are determined by the designer of the suspension, according to the design goals and the intended application. Other purposes of suspension system are to isolate sprung mass from the unsprung mass vibration,

to provide directional stability during cornering and to maneuver and provide damping for the high frequency vibration induced tire excitations. The passive suspension system is an open loop control system. It only designs to achieve certain condition only. The characteristic of passive suspension fix and cannot be adjusted by any mechanical part.

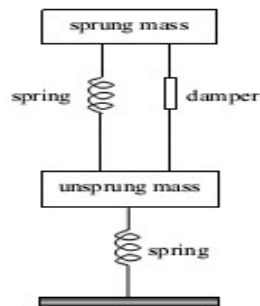

Fig 2 Quarter Car Passive Suspension System.

The problem of passive suspension is if it designs heavily damped or too hard suspension it will transfer a lot of road input or throwing the car on unevenness of the road.

Adaptive Suspension System.

Adaptive systems can usually change certain characteristics slowly to adapt to changes in vehicle load, speed or other operating conditions. These changes may take a few seconds or few minutes to have an effect. Self leveling is best known example. Self leveling is accomplished by using the energy that is generated by relative movement between the vehicle body and suspension whilst moving.

Semi Active Suspension System

Semi-active suspension system is quite similar with the conventional suspension system. This kind of suspension has a spring and controllable damper in which the spring element is used to store the energy meanwhile the controllable damper is used to dissipate the energy. Some of the semi-active suspension systems use the passive damper and the controllable spring, the controllable damper usually acts with limited potential to create a controlled force when dissipating energy.

A semi-active suspension is identical to passive suspension system with only varying damping

coefficient and constant spring constant one without active force sources. Thus, the mechanical outline of a semi-active suspension is identical like a passive one. However, some control of damping coefficient can be attained by changing the characteristics of dampers. As a result, there is risk of the damper reaction forces. A semi-active suspension can be electrically switched to either soften or stiffen the suspension. Its damping coefficient can be changed continuously or discontinuously.

For large road wheel movements, moreover, it is often used to switch from the soft to hard settings to prevent crash-through of the suspension on irregular road surfaces. The soft setting is restored after a few seconds of fairly straight and constant speed driving.

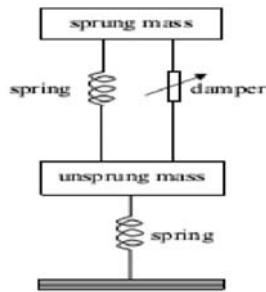

Fig 3 Quarter Car Semi-active Suspension System

It can be seen that semi-active suspensions works under closed-loop control. There are two types of dampers used in semiactive suspension system which are ER dampers and MR dampers.

ER dampers are consists of electrorheological fluids which are suspensions of micron sized particles in non-conductive oils or similar fluids. ER materials exhibit a dramatic change in properties when stimulated by an electrical field. These fluids have been proposed by several researchers as an effective means of providing fast response from a structural control system. From the engineer’s viewpoint, the most appealing changeable characteristic of ER materials is apparent fluid viscosity.

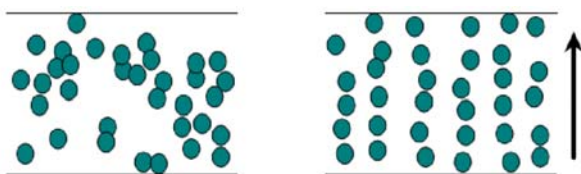

Fig 4.(a) Before an external (b) Structure of an ER electric field after electric field

With modern ER fluids, the application of an electrical stimulus changes the fluid viscosity from a relatively low, oil-like character to that of a viscous gel, exhibiting rubber-like viscoelastic properties. One obvious use of this material in structural control is to use the viscosity change to alter the output of a fluid damper. The damper includes orifices which bypass fluid with relatively low resistance when the ER fluid is not stimulated. When an electrical input is applied to the fluid, it reverts to its gel-like state within a very short time period, often approximating 1 millisecond.

MR fluids are non-colloidal suspensions of magnetizable particles that are on the order of tens of microns (20-50 microns) in diameter. MR fluid is composition of oil, usually mineral or silicone based, and varying percentages of ferrous particles that have been coated with an anti-coagulant material. When inactivated, MR fluid displays Newtonian-like behavior. When exposed to a magnetic field, the ferrous particles that are dispersed throughout the fluid ferromagnetic dipoles. These magnetic dipoles align themselves along lines of magnetic flux, as shown in Figure 5.

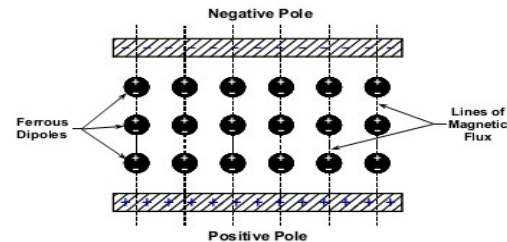

Fig. 5 Dipole alignment of ferrous particles

Varying the magnetic field strength has the effect of changing the apparent viscosity of the MR fluid. The reason why the phrase "apparent viscosity" is used instead of "viscosity" is that the carrier fluid exhibits no change in viscosity, but the MR fluid mixture thickens—even becoming a solid—when it is exposed to a magnetic field. The magnetic field changes the shear strain rate of the MR fluid, in the same sense that the fluid becomes more sensitive to shearing with an increasing magnetic field. As the magnetic field strength increases, the resistance to fluid flow at the activation regions increases until the saturation current has been reached. The saturation current occurs when increasing the electric current fails to yield an increase in damping force for a given velocity. The

resistance to fluid flow in the activation regions is what causes the force that MR dampers can produce. This mechanism is similar to that of hydraulic dampers, where the force offered by hydraulic dampers is caused by fluid passage through an orifice. Variable resistance to fluid flow allows us to use MR fluid in electrically controlled viscous dampers and other devices.

Active Suspension System

Active suspensions usually replace spring and dampers with fast hydraulic, pneumatic or electric actuators. A soft spring is often used in parallel with the actuator to reduce power consumption by carrying the static wheel load. Active systems are still in the prototype stage and suffer from high power demands and cost. Active suspension has the ability to add significant amounts of energy to the system.

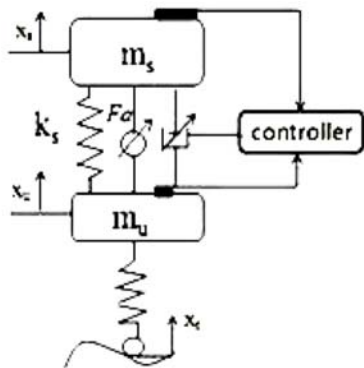

Fig.6. Active Suspension System

I. EXPERIMENTAL SET UP AND RESULT

The test set up for 2 DOF QC-PSS is developed, as shown in Fig 7. This is an assembly of a sprung mass, two linear springs, passive damper and motion sensors. The signals from the accelerometers on sprung mass for displacement, velocity and acceleration were acquired and processed by FFT analyzer.

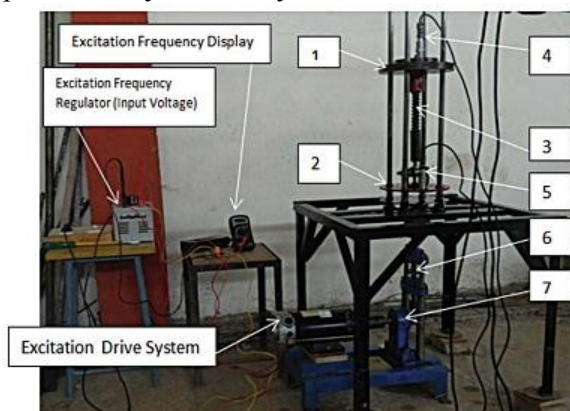

Fig.7. 2 DOF-QC-PSS Model

The 2DOF modeling approach is selected as it is capable of capturing all the important dynamic response characteristics of the quarter-car model. The mechanism for road disturbance input was developed with the goal of driving the suspension system in the vertical direction. A cam-follower system is driven by a changeable speed DC motor with control panel. It was found that a circular cam with an offset bore would produce a very good estimate of a sinusoidal waveform when driving a load placed upon its surface. The cam had 0.03 m peak to peak stroke and it generated a waveform modeled as $r(t)=0.03\sin\omega t$. The system ensures that the follower will always be in contact with the cam during the working. A mounting plate along with the guide bars provides an arrangement for setting (i) 2 DOF QC-PSS configuration Accelerometer 1 has been mounted on the sprung mass plate to determine the responses $x_s(t)$, $\dot{s}(t)$, $\ddot{s}(t)$.

In the experimental set-up, a variable speed DC motor is attached to a cam and follower mechanism to provide harmonic base excitation at desired amplitude and frequency. It is mounted on a rigid cast iron base fixed on a firm concrete foundation.

Necessary instrumentation for obtaining time based data for sprung mass displacement and base excitation and converting them in graphical form, using FFT interfacing system has been developed and vertical displacement $x_s(t)$, velocity $\dot{s}(t)$ and acceleration response $\ddot{s}(t)$ been carried out respectively, for sprung mass. When excitation frequency was set at 41.63 rad/s, which is near the first natural frequency of the system and the curves of $x_s(t)$, $\dot{s}(t)$ and $\ddot{s}(t)$ have been obtained using the FFT analyzer. Here we are taking in consideration only ride comfort so we will only consider all the results related to sprung mass of the system.

Experimental results of 2 DOF QC-PSS

The peak value of $x_s(t)$ is 1.75 mm. The peak value of $\dot{x}_s(t)$ is 1.9 mm/s. Similarly, peak value of $\ddot{s}(t)$ is 0.52 mm/s².

To improve the ride comfort and response characteristics of 2DOF QC-PSS,

damper with ER fluid is used to convert 2 DOF QC-PSS model to a 2 DOF QC-S-ASS model. Current about is supplied using device to switch the properties of ER fluid.

Selection of ER-Fluid

Electro rheological fluids basically consist of particles that are held in suspension by a non-conducting fluid. The suspending liquid which should have a high electrical resistivity is typically low viscosity hydrocarbon or silicone oil. The particles dispersed in this liquid are commonly metal oxides, alumino silicates, silica, organics or polymers. In particular, the particles are very small and have sufficiently low concentration to allow the fluid to maintain a relatively low viscosity in the absence of an applied electric field.

In this experiment, Er-fluid which is mixture of Arabic Gum and Silicon oil is used. It is used in damper for testing its suspension ability. The damper is properly insulated and fitted on test rig. As shown in fig.8.

2 DOF QC-S-ASS Model

Fig.8. shows test rig and damper used to compare the results between passive and semi-active suspension system. The damper is provided with current to switch its rheological properties.

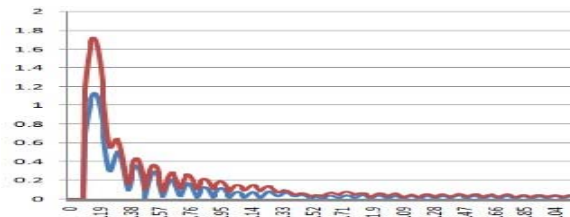

Fig.8. 2 DOF-QC-S-ASS Model

Comparison of Results between Passive and Semiactive Suspension.

Fig.9 show results between passive and semiactive suspension system. The results are plotted of sprung mass

displacement, sprung mass velocity sprung mass acceleration. As we are concerned about ride comfort here results of sprung mass are considered. For handling or road holding we consider parameters related to unsprung mass.



Comparison of Displacement

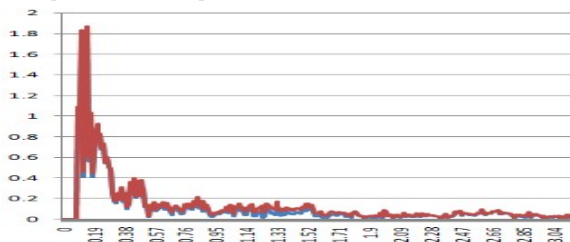

Comparison of Velocity

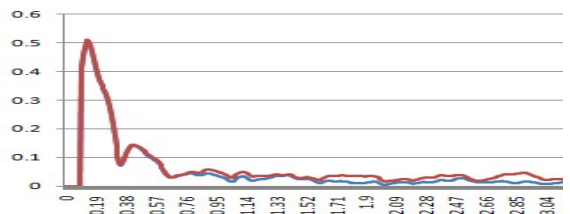

Comparison of Acceleration

— Passive Suspension, ——— Semiactive Suspension

Experimental results of 2 DOF QC-S-ASS

The peak value of $x_s(t)$ is 1.175 mm. The peak value of $\dot{x}_s(t)$ is 1.89 mm/s. Similarly, peak value of $\ddot{x}_s(t)$ is 0.495 mm/s².

Table No.1 Comparison of results between Passive and Semiactive Suspension System.

Parameter	Passive	Semiactive
Displacement $x_s(t)$	1.75 mm	1.175 mm.
Velocity $\dot{x}_s(t)$	1.9 mm/s	1.89 mm/s
Acceleration $\ddot{x}_s(t)$	0.52 mm/s ²	0.495mm/s ²

Conclusions

From grand literature some conclusions can be made on basis of some parameters and their distinguishing importance.

- 1) Design of adequate suspension system is a highly a difficult control problem due to the complicated relationship between its components and parameters. The researches were carried out in suspensions systems cover a broad range of design issues and challenges.
- 2) There are two criteria of good vehicle suspension Performance: the first one is typically their ability to provide good road handling and the other is grantee the passenger comfort. The main disturbance affecting these two criteria is terrain irregularities.
- 3) Comparison of different suspension system can be tabulated as follows.

Parameter	Passive	Semiactive	Active
Spring (Stiffness)	Fixed	Fixed	Fixed
Damper Damping Coeff.)	Fixed	Varying	Varying
Actuating Force	NA	NA	Provided

- 4) The present studies of electromagnetic active suspensions handle with permanent-magnet linear actuators, in which rare-earth materials are used in order to enhance force density. Thelinear switched reluctance actuator should be the feasible alternative, due to its simple and firm configuration, low cost, and sustainable development without any rare-earth materials.
- 5) From experimental results it is found that semiactive suspension gives good ride comfort than passive suspension system. As the graphs of displacement, velocity and acceleration shows the values of all parameters less than passive suspension system.

References

R. A. Williams (1994), Electronically Controlled Automotive Suspensions, Computing & Control Engineering Journal, Volume: 5, Issue: 3, 1994, pp. 143-148

M. Appleyard and P. E. Wellstead(1995), Active Suspensions-Some Background IEE Proc.-Control Theory Appl., Vol.142, No. 2, pp. 123-128.

I. Martins, M. Estevez, F. Pina da Silva, and P. Verdelho (1999), Electromagnetic Hybrid Active-Passive Vehicle Suspension System, IEEE 49th Vehicular Technology Conference, Vol. 3, pp. 2273-2277.

Website:<http://www.automobilesreview.com/auto-news/maserati-quattroporte-sport-gt-s-2/13824/>.

ISO/DIS 5349 & ISO 2631 – 1978, human sensitivity band.

Daniel Fischer, Rolf Isermann(2004), “Mechatronic semi-active and active vehicle suspensions”, journal of Control Engineering Practice 12 1353–1367.

Website:http://www.bmw.com/com/en/new-vehicles/6series/coupe/2007/allfacts/engine_dynamicdrive.html

Cao, H. Liu, P. Li, and D. J. Brown (2008), State of the Art in Vehicle Active Suspension Adaptive Control Systems based on Intelligent Methodologies, IEEE Transactions on Intelligent Transportation Systems, Vol. 9, NO. 3, pp. 392-405.

G. Corriga, S. Sanna, and G. Usai (1991), An Optimal Tandem, Active-Passive Suspension System for Road Vehicles with Minimum Power Consumption, IEEE Transactions on Industrial Electronics, Vol. 38, NO. 3, JUNE, pp. 210-216

Website:<http://www.mercedesbenz.com.cn/.../comfort.0002.html>

Anakwa, W.K.N., Thomas, D.R & Jones, S.C.(2002). Development and control of a prototype pneumatic active suspension systems. IEEE Transactions on Education,45, 43–49.

JBart L. J. Gysen, Johannes J. H. Paulides, Jeroen L. G. Janssen, and Elena A. Lomonova (2008), Active Electromagnetic Suspension System for Improved Vehicle Dynamics, IEEE Vehicle Power and Propulsion Conference, pp 1-6.

Bart L. J. Gysen, Johannes J. H. Paulides, Jeroen L. G. Janssen, and Elena A. Lomonova (2010), Active Electromagnetic Suspension System for Improved Vehicle Dynamics, IEEE Transactions on Vehicular Technology, VOL. 59, NO. 3, pp. 1156-1163.

Hsu, P,(1996) Power Recovery Property of Electrical Active Suspension Systems, Energy Conversion Engineering Conference, vol. 3, pp. 1899-1904.

W. D. Jones (2005), Easy Ride, IEEE Spectrum, Vol. 42, Issue 5, pp. 12-14

G. Kassakian, H C. Wolf, J. M. Miller, and C. J. Hurton (1996), The Future of Automotive Electrical Systems, Power Electronics in Transportation, pp. 3-12.

Website:<http://www.bose.com/controller?url=/automotive/index.jsp>

S. Buma, H. Kajino, T. Takahashi, and S. Doi (2008), Consideration of a Human Dynamic Characteristic and Performance Evaluation of an Electric Active Suspension, IEEE/ASME International Conference on Advanced Intelligent Mechatronics, pp. 1030-1036

C.Graf, J. Maas, and H.-C. Pflug(2009), Concept for an Active Cabin Suspension, IEEE International Conference on Mechatronics, pp. 1-6

Morteza Montazeri-Gh, Mehdi Soleymani (2010), Investigation of the Energy Regeneration of Active Suspension System

in Hybrid Electric Vehicles, IEEE Transactions on Industrial Electronics, VOL. 57, NO. 3, MARCH, pp. 918-925.

Abroon qazi, Umar A. Farooqui, Afzal Khan, Tahir khan (2013), Optimization of semi active suspension system using particle swarm optimization algorithm, AASRI conference on intelligent systems and control. pp. 161-166.

Bassam, A., Ahmad, A. F., & Mohamed, E. (1997). Optimal linear preview control of slow-active suspension systems. Proceedings of the 7th Saudi Engineering Conference (SEC7), Riyadh, pp. 1-11.

Cao, D., Song, X., & Ahmadian, M. (2011, January-February). Editors' perspectives: Road vehicle suspension design, dynamics, and control. Vehicle System Dynamics, 49(1-2), 3-28.

Karnopp, D. (1986). Theoretical limitations in active vehicle suspensions. Vehicle System Dynamics, 15, 41-54.

Mache, A. R., & Joshi, S. G. (2007). Theoretical and experimental dynamic response analysis of a road vehicle suspension system using electromagnetic damper. Proceedings of the International Conference on Advances in Machine Design and Industrial Automation, College of Engineering, Pune, pp. 144-149.

Nagai, M. (1993). Recent researches on active suspensions for ground vehicles. JSME International Journal, Series C, 36(2), 161-170.