



FOUR QUADRANT OPERATION AND SPEED CONTROL OF BLDC MOTOR

Gomathy S¹, Glory Priyadharshini J², Angalin E³

^{1,2,3}Assistant Professor, Department of EEE, Sri Ramakrishna Institute of Technology, Coimbatore

Abstract

Brushless Direct Current (BLDC) Motors are gaining higher priority in industrial automation, computers, aerospace, military, household appliances and traction applications because of their high efficiency, high power density and low maintenance cost. This makes the control of a BLDC motor in all four quadrants very vital. To control a BLDC drive, it is generally required to measure the speed and position of rotor by using the hall sensors. In this project, an attempt is made to study the four quadrant operation of a BLDC motor and also controlling the speed of the BLDC motor using PWM input to drive the motor by ARDUINO, and an emphasis is also made on the regenerative braking to increase the efficiency. BLDC motor requires a complex control to cope with the reversal of energy flow during transition from motoring to regenerative braking and this braking operation can be enhanced using a flywheel mechanism. This would conserve more energy that could be fed back to a battery storage system. This energy can further be used in an electric vehicle during the failure of the main supply, thus extending the driving range of the vehicle. Further, speed control based on user inputs is another aspect of the project which is implemented using the feedback from a simple IR sensor module.

Index Terms: BLDC motor, Arduino, Four quadrant, flywheel, Speed Control.

I. INTRODUCTION

Brushless dc motor is generally an DC motor turned in and out, which the stator with windings and rotor is permanent magnet. It has less inertia

so that we can start and stop very easily and disabling the motor becomes simple. The solid state switches replaces the working of brushless and commutator so that it is called maintenance free motor. The motor is operated by switching of poles excitations in the stator which creates back EMF that rotates rotor of BLDC motor. In recent years various types of control mechanism are developed for BLDC motor. The four quadrant operation without any losses of power using battery to save energy during transition between quadrants[1], to make fast transition between quadrants and to improve speed control uses FPGA controller which is more advantageous than conventional controllers this control enhances the switching sequences and also stores the wasted energy during braking for further uses [2]. hysteresis controller is used as a study in matlab simulink model with a closed loop control speed error is minimized [3]. Genetic algorithm ie, intelligent controllers are used to achieve excellent speed control of this motor and conventional PID controller are designed by genetic algorithm by using this type of controllers gives better performance than other conventional controllers [4]. And the sensorless control are employed by estimating the back EMF constant [5].

For the speed control of BLDC motor speed is controlled by using position of rotor it is sensed by internal hall sensor and switching the phases of motor based on hall sensor that makes rotor to rotate [6]. Microcontroller used for switching between phases [7]. Four switch three phase inverter used which reduces the cost of semiconducting switches [8]. So far the control of BLDC motor have been increasing by various new techniques to operate the motor in an optimum manner.

This paper is an attempt made to study the four quadrant operation of BLDC motor in real time applications like electric vehicles and also the speed control of the BLDC motor is also carried out by the arduino. The BLDC motor drive used is manufactured for user inputs to control motor that can be speed, reversing, braking, and disabling. The speed of the motor is controlled by the PWM pulses that drive's the motor. From the IR sensor the speed is captured and gives feedback to the arduino which is compared with the desired value, based on the comparisons arduino generates PWM pulses that is used to control the speed of the motor. For further increasing the efficiency of motor regenerative braking is used, the power from the motor windings returns back to the supply this excess power is stored in a battery for further uses when the main supply fails in vehicles the stored energy can be utilised. flywheel mechanism is used for longer braking period instead of tyres in electric vehicles the stored kinetic energy from the flywheel is delivered even after the motor is cut off from the supply so that it rotates for longer period due to the mass of flywheel.

II. FOUR QUADRANT OPERATION

There are four possible modes or quadrants of operation are possible in Brushless DC Motor which is depicted in Fig 1. In X-Y plot of speed versus torque, Quadrant 1 is forward speed and forward torque. The torque is propelling the motor in forward direction. Conversely, Quadrant 3 is reverse speed and reverse torque. Now the motor is "motoring" in the reverse direction, but torque is being applied in reverse. Torque is being used to "brake" the motor , and the motor is now generating power as result.

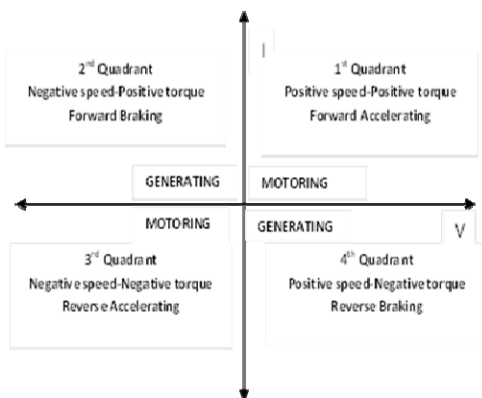

Fig.1 Four Quadrant Operation

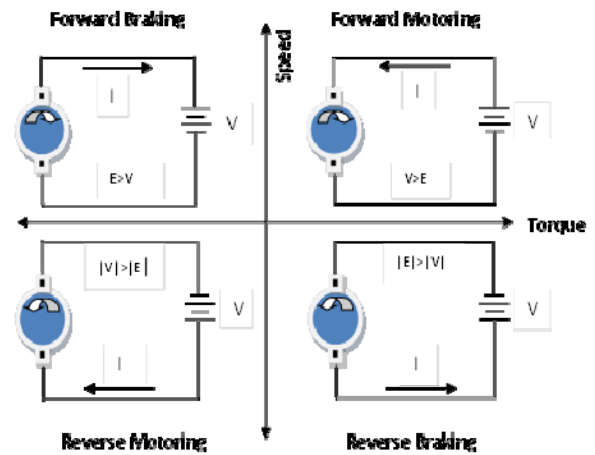

Fig. 2 Operation modes

Finally, Quadrant 4 is exactly the opposite. The motor is spinning in the direction, but the torque is being applied in forward direction. Again, torque is being attempt to slow the motor and change its direction to forward again. Once again, power is being generated in motor.

When BLDC motor (Fig.2) is operating in the first and third quadrant, the supplied voltage is greater than the back EMF which is forward motoring and reverse motoring modes respectively, but the direction of current flow differs[5]. When the motor operates in the second and fourth quadrant the value of the back EMF generated by the motor should be greater than the supplied voltage which are the forward braking and reverse braking modes of operation respectively, here again the direction of current flow is reversed. The BLDC motor is initially made to rotate in clockwise direction, but when the speed reversal command is obtained, the control goes into the clockwise regeneration mode, which brings the rotor to standstill position. Instead of waiting for the absolute standstill position, continuous energization of the main phase is attempted. This rapidly slows down the rotor to a standstill position. Therefore, there is the necessity for determining the instant when the rotor of the machine is ideally positioned for reversal. Hall effect sensor are used to ascertain the rotor position and from the Hall sensor outputs, it is determined whether the machine has reversed its direction. This is the ideal moment for energizing the stator phase so that the machine can start motoring in the counter clockwise direction[4]-[6].

III. BLDC MOTOR CONTROL

Two separate modules are required in order to control a BLDC motor. The two modules are power module and a control module.

A BLDC motor requires a DC source voltage to be applied to its stator windings in a sequence so as to sustain rotation. It is done by electronic switching using an inverter circuit as shown in Fig.3. The circuit employ a half n-Bridge for each stator winding Controller is used to read the rotor position information from the Hall Effect sensors and determine which phase to energize.

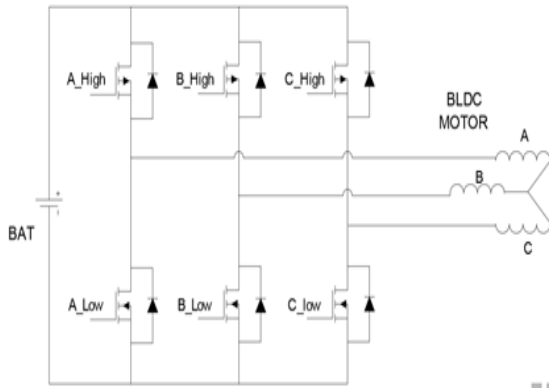

Fig. 3 Inverter Circuit

In case, if a BLDC motor has three pairs of stator windings, a pair of switches must be turned ON sequentially in the correct order to energize a pair of windings. This commutation sequence is shown in the Table I with “0” designating the pair of stator windings (phase) which are energized during this commutation step. Table I shows the corresponding switching sequence.

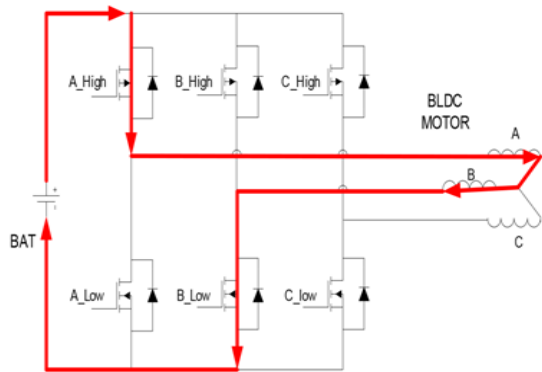

Fig. 4 Energisation of Phases A & B

Fig-4 illustrates the current flow from the inverter circuit at the first commutation step to energize the winding pair of phases A and B.

A similar strategy can be applied to achieve reversal of the sense of rotation, as shown in the Table II. A number of switching devices can be used in the inverter circuit. However MOSFET

and IGBT devices are the most common in high power applications due to their low output impedance. Switching the appropriate devices as depicted in the Table I,II. Alternatively, phase EMFs can be monitored to determine the rotor position in sensor less applications [9].

I. Switching sequence for *CLOCKWISE* direction

States of Hall sensors			States of switches in three phase inverter					
H_U	H_V	H_W	S1	S2	S3	S4	S5	S6
1	0	1	1	0	0	1	1	1
1	0	0	1	1	0	0	1	1
1	1	0	1	1	1	0	0	1
0	1	0	1	1	1	1	0	0
0	1	1	0	1	1	1	1	0
0	0	1	0	0	1	1	1	1

II. Switching sequence for *ANTI-CLOCKWISE* direction

States of Hall sensors			States of switches in three phase inverter					
H_U	H_V	H_W	S1	S2	S3	S4	S5	S6
1	0	1	1	1	1	1	0	0
1	0	0	0	1	1	1	1	0
1	1	0	0	0	1	1	1	1
0	1	0	1	0	0	1	1	1
0	1	1	1	1	0	0	1	1
0	0	1	1	1	1	0	0	1

IV. PROPOSED WORK

A. Regenerative braking using flywheel mechanism

Regenerative braking can be achieved by the reversal of current in the motor-battery circuit during deceleration, taking advantage of the motor acting as a generator, redirecting the current flow into the supply battery. Flywheel mechanism has been introduced into the system because flywheel is a kind of heavy wheel which needs really high potential to set it spinning. Just as it needs a lot of force to start it off. So it needs a lot of force to make it stop. As a result when braking is applied during high speed running condition it tends to keep rotating for larger time when compared to ordinary mounting on the motor shaft.

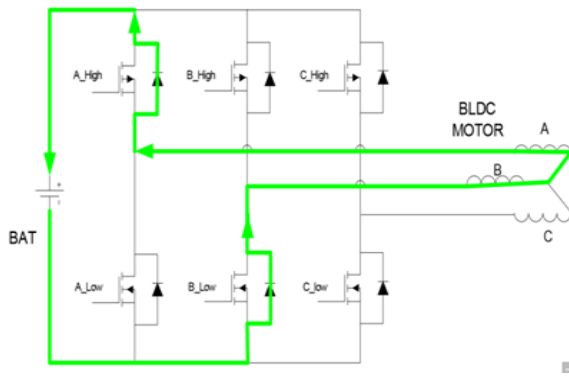

Fig. 5 Current In The Winding Reversed To Sources

This angular momentum persisting for long period could be used in terms of charging the battery. In this mode, current in the winding is reversed and supplied back into the battery. All switches are turned off and the current can flow back through the freewheeling diodes. Fig-5 shows an example of the current flow when the winding pairs of the A and B phases are energised. To control the level of braking the PWM duty cycle is varied, which essentially toggles the current flow between regeneration and coasting. The maximum level of regeneration occurs when the low-side switches are all turned off. Consequently the duty cycle is varied from high to low. Therefore, by simply disconnecting the inverter circuit from the control source controlling the inverters switching sequence, regenerative braking will occur to its maximum potential. The switching steps are controlled by the control stage measuring the Hall sensor readings, similar to the motoring process.

Regenerative braking can also be applied during the vehicle is in reverse. The same method is used as in the forward mode; however the phases are energised differently and thus require a different switching sequence.

The prototype is based on the ARDUINO platform, BLDC motor drive is controlled based on user inputs. The various controls include the forward, reverse throttle and dis-brake control through the help of switches making the motor to rotate in the concerned direction based on changing the switches strategy. The braking operation is done based on any interruption or obstacle in front of the car. This is sensed using the ultrasonic sensor and braking is applied automatically. The braking operation is

proceeded with the cutting down of the phase supply to the motor using a relay setup and the generated energy during this specific time interval is feed into the battery system through the charging circuit.

B. Speed control

Speed adjustment is another major concern in automotive application. There are various methods to calculate the speed of the BLDC motor, this prototype makes use of the Infrared sensor which is placed in front of the flywheel setup. The wheel is strike with a black line which is read by the IR sensor during the rotation as black surface absorbs the transmitted IR radiation which is sensed by the ARDUINO microcontroller. This black stroke indicates the completion of one complete rotation, so an algorithm can be framed based on the IR sensor input. The change in the edge from 0 to 1 can be taken as the completion of one complete rotation and time taken for this rotation is sensed using the micros () function in the ARDUINO IDE and this is further extended to calculate the revolutions per minute.

Fig-6 shows that the user defined speed can be set using the potentiometer knob and the set rpm is compared with the present rpm of the motor and the needed increment or decrement in the speed is inculcated by varying the PWM duty cycle. The PWM signal is processed through a circuitry which converts the low level PWM signals to the motor compatible one. Fig. 7 shows the speed control of BLDC motor.

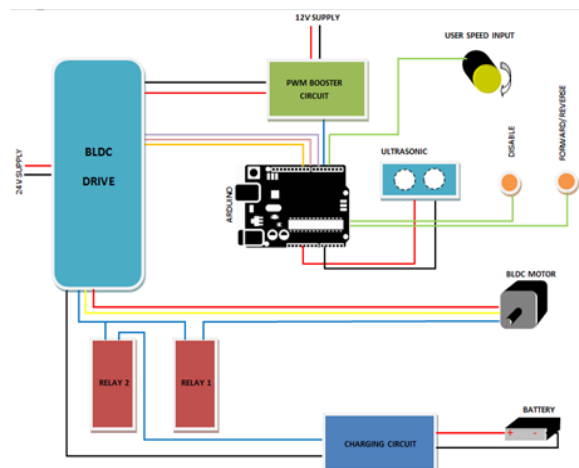

Fig. 6 Block Diagram



Fig. 7 Hardware setup

V. CONCLUSION

The project results shows the controlling of BLDC motor with a ARDUINO platform and regenerative braking is also applied to make it as an energy efficient motor. In future this system can be incorporated with GPS/GSM module to ensure it as an smart system.

REFERENCES

- [1] V. Vijayakumar V.Udayakumar and J. Muruganandham, "Speed Control Of BLDC Motor For Four Quadrant Operation Without Loss Of Power", International Conference On Computation Of Power, Energy, Information And Communication, pp.0541-0546, 2015.
- [2] K. Arun Babu and M. Vijayakumar, "Analysis of Four Quadrant Operation Of BLDC Motor With The Implementation Of FPGA", International Journal Of Innovative Research In Science, Engineering and Technology, vol. 3, pp. 976-983, February 2014.
- [3] A.S Sreesha, and P. Vandana,"Four Quadrant Operation Of BLDC Motor With Current Controller", International Journal Of Engineering Trends and Technology(IJETT),vol. 28, No. 2,pp. 85-90,ISSN: 2231-5381, oct-2015.
- [4] Md Mustafa Kamal, Lini Mathew and S. Chatterji,"Speed Control Of Brushless DC Motor Using Intelligent Controllers", IEEE 978-1-4799-4939-7/14, 2014.
- [5] Dong-Youn Kim, Jong-Joo Moon, Jang-Mok Kim, Jong-Seung Ji, "Sensorless control method of 3-Phase BLDC motor through the real time compensation of Back-EMF constant", IEEE 8th International Power Electronics and Motion Control Conference (IPEMC-ECCE Asia), 978-1-5090-1210-7/16, 2016.
- [6] Abhishek Padalkar, "Speed and Position Control of BLDC Motor Using Internal Hall Sensors and Hardware Design", International Conference on Information Processing (ICIP) 978-1-46733-7758-4/15 IEEE, December 2015.
- [7] G. SanthoshKumar, S. Arockia Edwin Xavier," Brushless DC Motor Speed Control Using Microcontroller", International Journal Of Current Engineering And Scientific Research (IJCESR), ISSN (PRINT): 2393-8374, (Online): 2394-0697, Vol-2, Issue-2, 2015.
- [8] M .S. Aspalli, Farhat Mubeen Munshi, Savitri. L. Medegar," Speed control of BLDC Motor with Four Switch Three Phase Inverter using Digital Signal Controller", International Conference on Power and Advanced Control Engineering (ICPACE), 978-1-4799-8371-1/15 IEEE, 2015.
- [9] Chen Youngjun, Raun Bo," Sensorless Control of BLDC Motor Drive for a Drilling Rig System in Shale Gas Developmen", IEEE 11th Conference on Industrial Electronics and Applications (ICIEA), 978-1-4673-8644-9/16, 2016.