



# QUALITY IMPROVEMENT IN MATRIX CONVERTER USING VENTURINI ALGORITHM

D.Thiyaharajan

Asst. Professor, Dept. of Electrical and Electronics Engg.,  
Dr.SivanthiAditanar College of Engineering.,Tiruchendur

## Abstract

**In this paper, a matrix converter (MC) which makes directly AC-AC power conversion is modelled based on FPGA and the control algorithm has been performed using a hardware description language (VHDL), which provides great flexibility and technology independence. The gate signals of the power switches of MC are produced using Venturini Modulation method. This method provides the amplitude of output voltage up to 86.6% of input voltage, and unity fundamental displacement factor at the input regardless of the load displacement factor. In this paper the duty cycles of the matrix converter switches are obtained from VHDL coding using Venturini algorithm.**

**Keywords: Matrix converter, OAVM method, Field Programmable Gate Array (FPGA), Very High Speed Integrated Circuits Hardware Description Language (VHDL).**

## I. INTRODUCTION

One of the most important processes in power electronics is to convert electric power to different forms. In controlling of the electric energy, the great advances are provided together with fast improvements in semiconductor power elements and power electronics converters.

The matrix converter providing directly ac-ac power conversion is one of the most interesting members of the power converter family. Matrix converter was introduced in 1976 and started to its improvement after the papers of Venturini and Alesina in 1980 . The proposed method by these authors is known as the Venturini method or the direct transfer function approach. In this method, gate-drive signals for the nine bidirectional switches are calculated to generate

variable-frequency and/or variable-amplitude sinusoidal output voltages from the fixed-frequency and the fixed-amplitude input voltages.

The MC has some advantages as follows according to traditional converter.

- Generation of output voltages with the desirable amplitude and frequency;
- Energy regeneration aptitude to the mains;
- Sinusoidal input and output currents;
- Controllable of input displacement factor regardless of the load
- Compact design due to the lack of dc-link components for energy storage.

In recent years, the development of application-specific integrated circuit (ASIC) technology has made it possible to integrate complex analog and digital circuits by utilizing the libraries of basic circuit cells. With the advancement of various technical aspects of ASIC, three major categories have been developed: cell based integrated circuits (CBIC), gate arrays, and programmable logic devices (PLD). The field-programmable gate array (FPGA) is a new PLD developed by Xilinx. The FPGA comprises thousands of logic gates, some of which are grouped together as a configurable logic block (CLB) to simplify the higher-level circuit design. The simplicity and programmability of the FPGA designate it as the most favourable choice for prototyping an ASIC. When compared with conventional schemes, the advantages of the FPGA include three aspects.

First of all, the FPGA IO resource is abundant . Secondly, the real time control needs faster digital circuits than before, and the performance of the FPGA to the design sequential logic

circuits is good .Lastly, the development environment of the FPGA is easy to use. The difficulty and time cost for the hardware design have been greatly reduced. In this work, the basic concepts of matrix converter are explained and the mathematical model of matrix converter is briefly given in a clear form. Optimum Amplitude-Venturini Modulation (OAVM) method is used to produce the gate signals driving bidirectional power semiconductors, and a maximum voltage transfer ratio (0.866) was obtained. An input filter is used at input side of converter. It smoothes distortion of the input current around the switching frequency and eliminates the generation of overvoltage produced during commutation of currents due to the presence of the short-circuit reactance of any real power supply. The working principles of MC producing the output voltages at various amplitude and frequency are analyzed. Also, simulation results of OAVM method based matrix converter are given.

**II. THE BASIC TOPOLOGY OF MATRIX CONVERTER**

The matrix converter is a single-stage converter, which is composed of an array of m x n bidirectional power switches, each connected between one phase of the input and one phase of the output. Theoretically, the number of input phases, m must be at least three, and the number of output phases, n can be chosen from one to infinity. The basic matrix converter topology which connects a three-phase voltage source to a three-phase load as shown in Fig. 1 is the most important converter from a practical point of view [2]. A matrix converter is an unlimited frequency changer, which can generate both smaller and bigger output frequency than input frequency of the converter. The output voltage waveforms are constructed by piecing together selected segments of the input voltage waveforms.

Each switch is characterized by a switching function, defined as follows [1],

$$S_{Kj}(t) = \begin{cases} 0 & S_{Kj} \text{ is open} \\ 1 & S_{Kj} \text{ is closed} \end{cases} \quad (1)$$

Each switch,  $S_{Kj}$ ,  $K=\{A,B,C\},j=\{a,b,c\}$  can connect or disconnect phase  $K$  of the input stage to phase  $j$  of the load. Output voltages  $V_{jN}$  can

be synthesized by switching according to a proper combination of these switches.

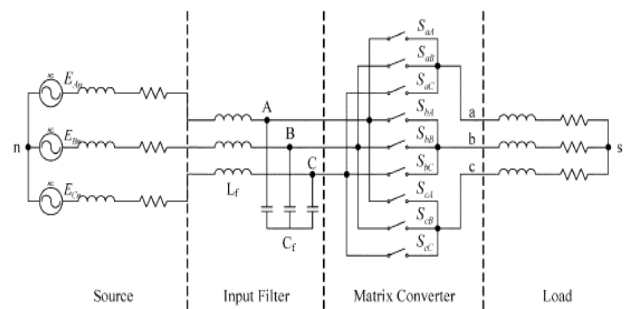

Fig.1. The basic matrix converter topology

Control of the matrix converter must comply with the following basic two rules. Firstly, any two input terminals should never be connected to the same output line to prevent short-circuit, because the MC is fed by a voltage source. The other, an output phase must never be open-circuited, owing to the absence of a path for the inductive load current which leads to the over-voltages. The above two constraints can be expressed by (2).

$$\sum_{K=A,B,C} m_{Ka}(t) = \sum_{K=A,B,C} m_{Kb}(t) = \sum_{K=A,B,C} m_{Kc}(t) = 1$$

When these rules are provided, the 3 x 3 matrix converter can allow only 27 different switching states among the possible 512 switching combinations. To derive modulation rules, it is also necessary to consider the switching pattern that is employed. This typically follows a form similar to that shown in the Fig.2. By considering that the bidirectional power switches work with high switching frequency, a low-frequency output voltage of variable amplitude and frequency can be generated by modulating the duty cycle of the switches using their respective switching functions.

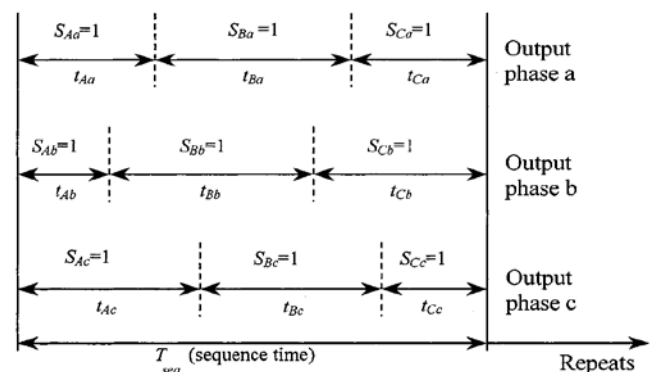

Fig.2. General form of switching pattern.

Let  $m_{Kj}(t)$  be the duty cycle of switch  $S_{Kj}$ , defined as,  $m_{Kj}(t)=t_{Kj}/T_s$  which can have the following values

$$0 < m_{Kj} < 1, K = \{A, B, C\}, j = \{a, b, c\}$$

### III. VENTURINI METHOD FOR MATRIX CONVERTER

In 1980, Venturini and Alesina presented a converter, which consists of bidirectional power switches constructed as matrix and they introduced to as “matrix converter”. In addition to, they proposed a PWM modulation method for the control of matrix converter. The proposed method by these authors is known to as the Venturini method or the direct transfer function approach.

In Venturini method, the appropriate firing pulses to each of the nine bidirectional switches must be calculated to generate variable-frequency and/or variable-amplitude sinusoidal output voltages from the fixed-frequency and the fixed-amplitude input voltages.

In this paper,  $V_{sA}, V_{sB}, V_{sC}$  are the source voltages,  $i_{sA}, i_{sB}, i_{sC}$  are the source currents,  $v_{jn}$ ,  $j = \{a, b, c\}$  are the load voltages with respect to the neutral point n of the load, and  $i_j$ ,  $j = \{a, b, c\}$  are the load currents. Also, other variables have been defined to be used as a basis of the modulation and control strategies:  $v_i$ ,  $i = \{A, B, C\}$  are the MC input voltages,  $i_j$ ,  $j = \{A, B, C\}$  are the MC input currents, and  $v_{jN}$ ,  $j = \{a, b, c\}$  are the load voltages with respect to the neutral point N of the grid.

If it is defined as  $t_{Kj}$ : the time during which switch  $S_{Kj}$  is on and  $T_s$ : the sampling interval,  $m_{Kj}(t)=t_{Kj}/T_s$  duty cycle of switch  $S_{Kj}$ , modulation matrix is given in (3).

$$M(t) = \begin{bmatrix} m_{1a}(t) & m_{1b}(t) & m_{1c}(t) \\ m_{2a}(t) & m_{2b}(t) & m_{2c}(t) \\ m_{3a}(t) & m_{3b}(t) & m_{3c}(t) \end{bmatrix} \quad (3)$$

Under ideal conditions, the three-phase sinusoidal input voltages of the MC can be given as,

$$[v_i(t)] = v_{im} \begin{bmatrix} \cos(\omega_1 t) \\ \cos(\omega_1 t + 2\pi/3) \\ \cos(\omega_1 t + 4\pi/3) \end{bmatrix} \quad (4)$$

In accordance with this, each output phase voltages can be expressed by (5).

$$[v_o(t)] = qv_{im} \begin{bmatrix} \cos(\omega_o t) \\ \cos(\omega_o t + 2\pi/3) \\ \cos(\omega_o t + 4\pi/3) \end{bmatrix} \quad (5)$$

$$[v_{jN}(t)] = [M(t)][v_i(t)] \quad (6)$$

In the same way, the input currents are also shown by expression in (6).

$$[i_i(t)] = [M(t)]^T [i_o(t)] \quad (7)$$

Where,  $[M(t)]^T$  is the transpose matrix of  $[M(t)]$

#### A. Voltage Ratio Of 50%

The first method attributable to Venturini is defined by [2]. However, calculating the switch timings directly from these equations is cumbersome for a practical implementation. They are more conveniently expressed directly in terms of the input voltages and the target output voltages (assuming unity displacement factor) in the form of (8)

$$m_{Kj} = \frac{v_{Kj}}{v_{imj}} = \frac{1}{3} \left[ 1 + \frac{2v_{Kj}v_j}{v_{im}^2} \right] \quad (8)$$

where  $K = \{A, B, C\}, j = \{a, b, c\}$

This method is of little practical significance because of the 50% voltage ratio limitation as shown in Fig.3.

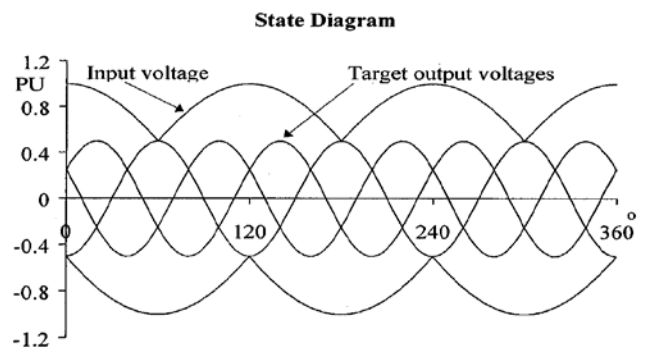

Fig.3. Illustrating maximum voltage ratio of 50%.

#### B. Optimum Amplitude Venturini Modulation (OAVM)

Venturini’s optimum method employs the common-mode addition technique to achieve a maximum voltage ratio of 87%. The amplitude of the output voltage is limited to 50 percent of the input voltage in the initial approach of Venturini Modulation method. To obtain a maximum voltage transfer ratio, third harmonics of the input frequencies are added to

the target output phase voltages and third harmonics of the output frequencies are subtracted from it as given in (9).

$$[v_{pki}(t)] = qv_{im} \begin{bmatrix} \cos(\omega_0 t) - \frac{1}{6}\cos(3\omega_0 t) + \frac{1}{24\sqrt{3}}\cos(3\omega_1 t) \\ \cos(\omega_0 t + 2\pi/3) - \frac{1}{6}\cos(3\omega_0 t) + \frac{1}{24\sqrt{3}}\cos(3\omega_1 t) \\ \cos(\omega_0 t + 4\pi/3) - \frac{1}{6}\cos(3\omega_0 t) + \frac{1}{24\sqrt{3}}\cos(3\omega_1 t) \end{bmatrix} \quad (9)$$

Where,  $q$  is the voltage gain or voltage transfer ratio. By this way, a voltage transfer ratio of 0.866 which is maximum value can be obtained. The third-harmonic injection of the input and output frequencies into the target output voltages has no effect on the output line-to-line voltages. The target output voltage equals the average output voltage during each switching sequence.

If unity input displacement factor is required in the optimum-amplitude Venturini method [2], [5], the algorithm can be more simple in the form of (10)

$$m_{Kj} = \frac{v_{Kj}}{V_{smq}} = \frac{1}{3} \left[ 1 + \frac{2v_{Kj}^{(1)}}{v_{im}^{(1)}} + \frac{2q}{3q_{im}} \sin(\omega_1 t + \beta_K) \sin(3\omega_1 t) \right] \quad (10)$$

Where  $K=\{A,B,C\}$ ,  $j=\{a,b,c\}$ ,  $\beta_K=\{0,2\pi/3,4\pi/3\}$

The common-mode voltages have no effect on the output line-to-line voltages, but allow the target outputs to fit with in the input voltage envelope with a value of up to 87% as illustrated in Fig. 4.

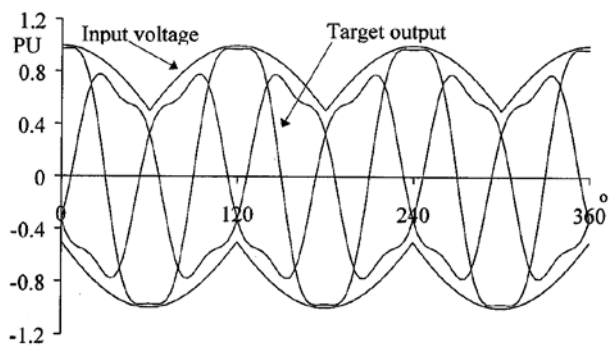

Fig.4. Illustrating maximum voltage ratio of 87%.

The improvement in voltage ratio is achieved by re distributing the null output states of the converter (all output lines connected to the same input line) and is analogous to the similar well-established technique in conventional dc-link PWM converters. It should be noted that a voltage ratio of 87% is the intrinsic maximum for any modulation method where the target

output voltage equals the mean output voltage during each switching sequence.

As shown in Fig. 5, signals,  $X$  and  $Y$  are obtained by comparing saw tooth signal with switching frequency and these calculated duty cycles.

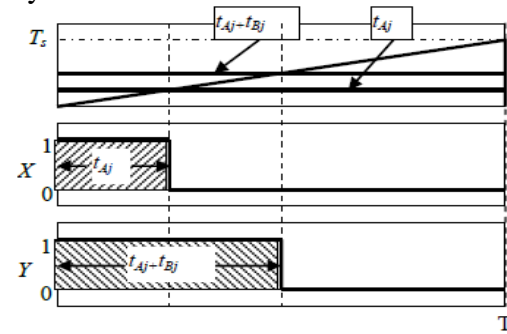

Fig.5. Obtaining turn-on-time of the power switches

Final gate drive signals  $S_{Kj}(t)$ , determining turn-on-time of the power switches can be obtained according to the logic statements in (11). Consequently, only duty cycles of six switches are sufficient to calculate the gate signals for all of the power switches

$$\left. \begin{matrix} X=t_{Aj} \\ Y= \\ t_{Aj}+t_{Bj} \end{matrix} \right\} \rightarrow \begin{matrix} S_{Aj}=(X) \\ S_{Bj}=\text{not}(X) \text{ and} \\ (Y) \\ S_{Cj}=\text{not}(X) \text{ and} \\ \text{not}(Y) \end{matrix} \quad (11)$$

A global Matlab & Simulink model of matrix converter which includes models of three-phase source, reference voltage, load, and especially the switching pattern is given in Fig.6. As a result, input and output currents, output phase voltages with respect to N ( $v_{aN}$ ,  $v_{bN}$ ,  $v_{cN}$ ) and  $n$  ( $v_{an}$ ,  $v_{bn}$ ,  $v_{cn}$ ), output line-to-line voltages ( $v_{ab}$ ,  $v_{bc}$ ,  $v_{ca}$ ) of matrix converter controlled with venturini method are attained using this model.

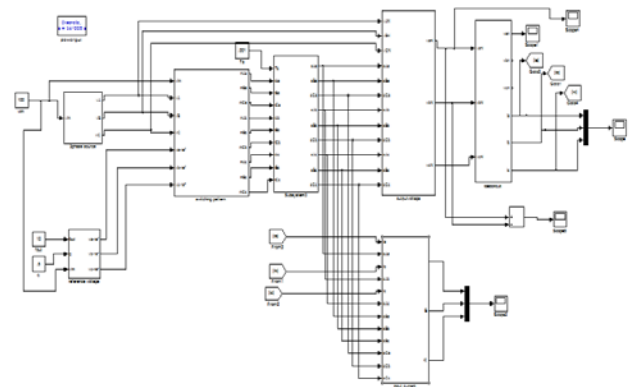

Fig.6. Matlab&Simulink model of the 3 x 3matrixconverter

IV. SIMULATION RESULTS

Parameters used in the developed simulation model have been given in Table I.

TABLE I  
SIMULATION PARAMETERS

Source voltage amplitude, $V_{im}$	325V
Input frequency, $f_i$	50Hz
Output frequency, $f_o$	25&50Hz
Load resistance, R	10Ω
Load inductance, L	30mH
Switching frequency, $f_s$	2kHz
Voltage transfer ratio, $q$	0.5&0.8

Simulation of matrix converter has been performed to produce output with variable frequency from input with fixed frequency. In this paper, simulation results have been presented for only output frequencies of 25 and 50 Hz from an input of 50 Hz.

Table 2 shows the THD analysis of output line voltages of matrix converter and it is easily shown from table that harmonics components are reduced in line voltages of the Optimum Amplitude Venturini Modulation (OAVM) method. It is also cleared in the harmonic analysis spectrum shown in the Fig.9&13.

The Fig.7,8&12 shows the Output phase voltage of matrix converter with respect to the star point of load & output line to line voltages with the output frequency of 50Hz and  $q=0.5&0.8$

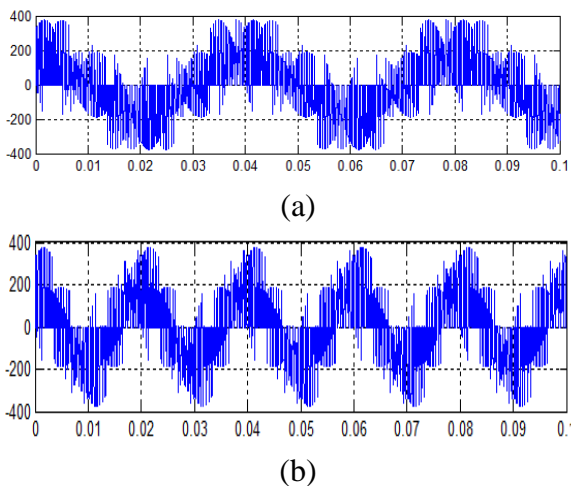

Fig. 7. Output phase voltage with respect to star point of load (a) in 25 Hz (b) in 50 Hz with  $q=0.5$

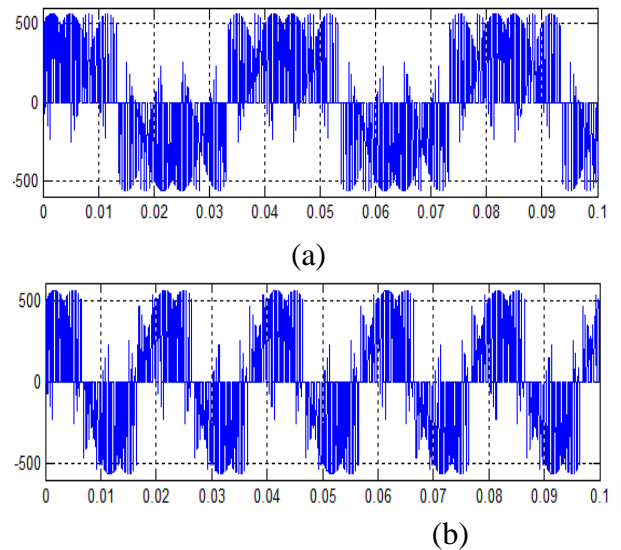

Fig.8 output line-to-line voltage: (a) in 25 Hz (b) in 50 Hz with  $q=0.5$

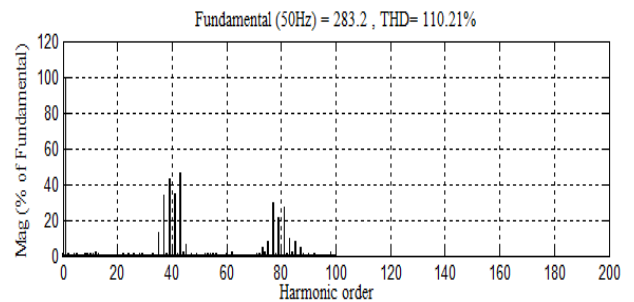

Fig.9.harmonic spectrum of line to line voltage with 50Hz& $q=0.5$

The Fig.10&11 shows the three phase output current of the matrix converter with output frequency 50Hz and the voltage transfer ratio of  $q=0.5&0.8$

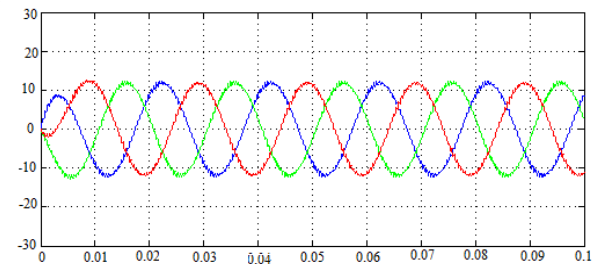

Fig. 10.Three phase output current with 50Hz & $q=0.5$

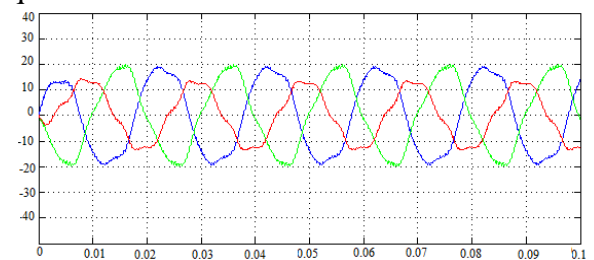

Fig.11. Three phase output current with 50Hz & $q=0.8$

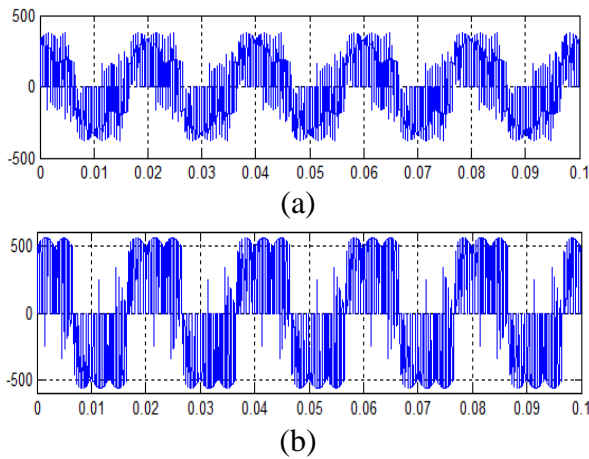

Fig.12 output line-to-line voltage & output phase voltage with respect to star point of load in 50Hz & q=0.8

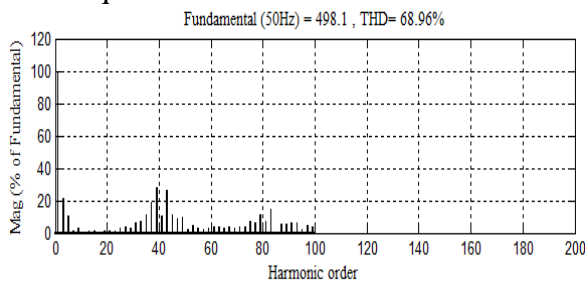

Fig.13.harmonic spectrum of line to line voltage with 50Hz & q=0.8

TableII: THD Analysis in Output Line Voltages

S.No	Voltage/frequency	q	THD(output line voltage)
1	230/50	0.5	110.21%
2	150/25	0.5	106.39%
3	230/50	0.8	69.02%
4	150/25	0.8	81.64%

### V. CONCLUSION

Matrix converter modelling based on FPGA using Venturini algorithm have been done. It is observed from above table that total harmonics distortions are reduced in line voltages of the OAVM method because of the triplen harmonics are almost zero in line voltages in the above cases. Modulation strategies and fundamental mathematical equations of the MC have been presented clearly. Also, modelling and simulation of the OAVM method, which can give an output voltage with maximum amplitude, has been implemented. The simulation results show that the modulation algorithm provides a unity input displacement

factor even if the load has an inductive characteristic.

### References

- [1] A.Alesina, M.Venturini, "Analysis and Design of Optimum- Amplitude Nine Switch Direct AC-AC Converters", IEEE Trans. Power Electron., vol. 4, no.1, pp. 101-112, Jan. 1989.P.W. Wheeler, J. Rodriguez, J.C. Clare, et al., "Matrix Converters: a Technology Review", IEEE Trans. Ind. Electron., Vol. 49, no.2, pp.276-288, April 2002.
- [2] K.Sun, D. Zhou, L. Huang, K. Matsuse, "Compensation Control of Matrix Converter Fed Induction Motor Drive under Abnormal Input Voltage Conditions", IEEE-IAS'04, pp. 623-630, 2004.
- [3] H.Karaca and R.Akkaya, "Modelling and Simulation of Matrix Converter under Distorted Input Voltage Conditions," Simulat. Modell.Pract. Theory (2010), doi:10.1016/j.simpat.2010.09.005, 2010.
- [4] H.Karaca and R.Akkaya, "Control of Venturini Method Based Matrix Converter in Input Voltage Variations," in Proceedings of the International Multi Conference of Engineers and Computer Scientists IMECS'09, vol II, 1412-1416, 2009, March 18-20, Hong Kong.
- [5] M. Venturini, "A New Sine Wave in Sine Wave out, Conversion Technique Which Eliminates Reactive Elements," in *Proceedings of Powercon 7*, pp. E3/1-E3/15, 1980.
- [6] J.Rodriguez,E.Silva, F.Blaabjerg, P.Wheeler, J.Clare, J.Pontt, "Matrix Converter Controlled with the Direct Transfer Function Approach: Analysis Modelling and Simulation", Taylor&Francis-International Journal of Electronics, vol. 92, no. 2, pp. 63-85, February 2005
- [7] K. Sun, D. Zhou, L. Huang, K. Matsuse, "Compensation Control of Matrix Converter Fed Induction Motor Drive under Abnormal Input Voltage Conditions", *IEEE-IAS'04*, pp. 623-630, 2004.
- [8] D. Casadei, G. Serra and A. Tani, "Reduction of the Input Current Harmonic Content in Matrix Converters under Input /Output Unbalance" *IEEE Trans. Ind. Electron.*, vol. 45, no. 3, pp. 401-409, June 1998.