



WIRELESS MEASUREMENT AND CONTROL SYSTEM FOR ENVIRONMENTAL PARAMETERS

Divya Priyadarshini M¹, Nishanthi M², Josephine R L³, Prabha Maheswari M⁴

Abstract

According to the environmental parameters, the aim is to monitor the requirements based on wireless measurement and control system for temperature, LDR and Co₂ is developed. It eradicates the disadvantages of wired monitoring system such as complicated wiring, and maintenance. Thermistor sensor used for measuring temperature followed by LDR sensor and Co₂ sensor for measuring light and gas. The environmental parameters were measured and controlled by microcontroller. ZigBee is used to transfer and also to receive the values of sensor and it will transmit to pc via interface communication. The hardware and software of the monitoring system was discussed in detail. The existing system concentrated mainly on greenhouse but this paper can be implemented for industries, agricultural and various commercial purposes. The experimental results show that the developed monitoring system has the following features such as high reliability, good extensibility and flexible configuration. The results can be easily checked and verified easily by using visual programming.

Keyword: Co₂, LDR and Temperature sensor, pic controller, RS232 and Zigbee.

I. INTRODUCTION

For the large use of rural distract wired monitoring system is difficult, such as complicated wiring, maintenance and so on. To overcome this, wireless monitoring system is developed which is based on ZigBee technology. Wired is most commonly done with point to point to multipoint technology [1] but ZigBee network provide complete transparency. For the application of wireless medium the ZigBee protocol places primary importance on power

management; it was developed for low power consumption and years of battery life then Bluetooth [1]

Companies developing monitoring and control applications in industrial and commercial building environments are looking to wireless technologies like ZigBee to save the cost of wiring and installation, ZigBee was developed to satisfy the market's need for a cost-effective, standards based wireless network that supports low data rates, low power consumption, security, and reliability [4]

This paper illustrates that the ZigBee wireless technology can perform well in industrial environments as well as agriculture in terms of performance and reliabilities. Starting from environmental controls, industrial controls, it is now being widely applied in military also. Its advantages include the liability, simplicity, and low cost in both installation and maintenance [5]

To monitor the environmental parameters in industry, commercial purpose, agriculture the thermistor, LDR, Co₂ sensor are used. The experimental setup consists of two segments one acts as a monitoring and the other for interfacing pc.

The monitoring segment consists of the following, Thermistor sensor is used to monitor the room temperature is well known for the application of low power system. LDR is used to control and monitor the illumination of light. If the carbon-di-oxide level in the room increases it is monitored by the Co₂ sensor.

The zigbee is used as a transceiver between monitoring side and pc. Here the visual program was developed for automatic monitoring the sensed value.

II. COMPARISON OF ZIGBEE, WI-FI, AND BLUETOOTH PROTOCOLS

Wi-Fi, Bluetooth and ZigBee work at similar RF frequencies, and their applications sometimes overlap. In the current study, we chose the following five main factors of environmental networks to compare: cost, data rate, number of nodes, current consumption and battery life [7]

(1) Cost. ZigBee chip is US\$ 1 or less, the lowest; Wi-Fi and Bluetooth chips are \$ 4 and \$3, respectively. The overall system cost can be significantly reduced by the employment of ZigBee chip.

(2) Data rate. ZigBee is 250 kbps, while Wi-Fi and Bluetooth are 54 Mbps and 1~2 Mbps, respectively. Despite the lowest data rate, ZigBee is sufficient for a greenhouse. Generally, data traffic in a greenhouse is low—usually small messages such as the change of temperature or a command from the controller to an actuator. And also, low data rate helps to prolong the battery life.

(3) Number of nodes. The capacity of network is determined by the number of nodes, and ZigBee has up to 254 nodes, the largest among the three. It meets the application demand of more and more sensors and actuators in a greenhouse.

(4) Current consumption. ZigBee has the lowest current consumption, 30 mA, while Wi-Fi, 350 mA, and Bluetooth, 65~170 mA. It also greatly helps to prolong the battery life.

(5) Battery life. ZigBee chip has the longest battery life, a few months or even years. As a whole, ZigBee technology offers long battery life, small size, high reliability, automatic or semi-automatic installation, and, particularly, a low system cost. Therefore, it is a better choice for greenhouse monitoring and control than other wireless protocols.

III. PROPOSED WORK

A. Measurement and control system

The block diagram of measurement and control system is showed in figure 1.

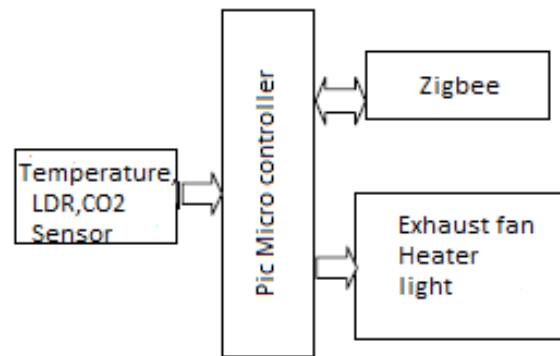

Figure 1 : Block Diagram of Measurement and Control Unit

It mainly includes data acquisition subsystems, wireless communication subsystems and control subsystems. It is mainly used to measure the temperature, carbon dioxide concentration and LDR, through respective sensors were micro controller was used to measure and control through pc via zigbee.

1) The microcontroller that has been used for this project is from PIC series. PIC microcontroller is the first RISC based microcontroller fabricated in CMOS, it consist of following features: Operating speed: DC - 20 MHz clock input, DC - 200 ns instruction cycle, Direct, indirect, and relative addressing modes, Watchdog Timer, In-Circuit Serial Programming via two pins, operating voltage range: 2.5V to 5.5V, Current range: 25 A

2) Zigbee was selected due to high performance, low cost, low power, advanced networking & security, easy to use, battery life 1 year, operating voltage: 12V, current consumption: 130mA.

The sensor is chosen in practical application in energy consumption, measuring range and precision, cost and volume, with the performance are shown as follows:

(1) Temperature sensor is chosen as thermistor, its performance index are: Wide operating temperature range: -50°C to 150°C, Overall lengths from 18mm to 78mm, response time is less than 8s , average power consumption is 20 μ W;

(2) LDR sensor is chosen due to its low cost, response time is less than 6s, long life;

(3) The concentration sensor of CO₂ is chosen as infrared CO₂ sensor of GS-106, It's main performance index are: measuring range is 0~5000ppm, response time is less than 4s, power supply is 3.3V DC, average power consumption is less than 100mW.

The controlling members for environment parameters consist of the controlling of heater, exhaust fan and light. If the temperature, LDR and co₂ concentration goes beyond the limit than PC can send out instructions to control solid state relay, then the heater, exhaust fan and light are turned on by solid state relay; Otherwise these controllers are turned out.

B. Power supply unit

The ac voltage, typically 220V rms, is connected to a transformer, which steps that ac voltage down to the level of the desired dc output. A diode rectifier then provides a full-wave rectified voltage that is initially filtered by a simple capacitor filter to produce a dc voltage. This resulting dc voltage usually has some ripple or ac voltage variation. A regulator circuit removes the ripples and also remains the same dc value even if the input dc voltage varies, or the load connected to the output dc voltage changes. This voltage regulation is usually obtained using 7805, 7812, 7912 voltage regulator IC units.

C. Serial communication circuit unit

The serial communication circuit accomplishes the communication between the PC and microcontroller. The system on the one hand collects the data which every terminal collected; on the other hand controls the action of ach terminal by the instruction of the PC. This serial communication circuit is designed based on RS232C serial interface for data transmission. The conversion between RS232 and TTL level by STC3232, because it is RS232C duplex transmitter/receiver interface chip, which has level multiplication circuit with spontaneously stepping up and only needs a single power supply of +3.3V.

IV. PROGRAMMING

A. Microcontrol programming

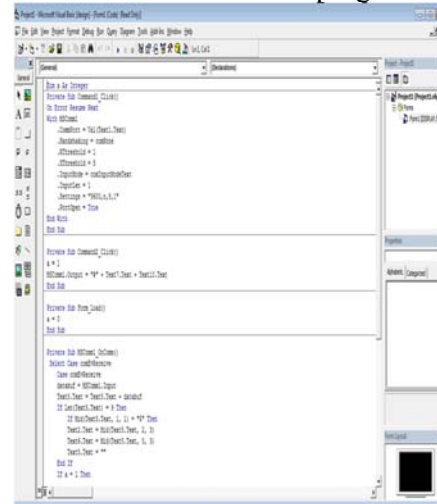

Figure 2 MATLAB program for Pic Microcontroller

MATLAB program was fed to the Pic microcontroller 16F877. It is used to control the temperature sensor, LDR and Co₂ (gas) sensor. The sensed values are fed to the pic there by it convert the analog input to the digital and send to the control circuit.

B. Interface control using VISUAL BASICS

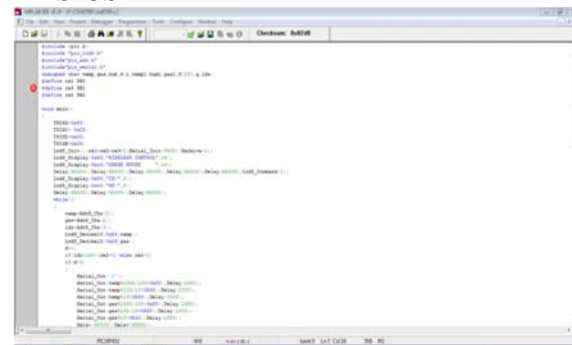

Figure 3 Visual basic program for measuring the sensor values

The program was developed for the comparison of temperature and co₂ (gas) with set value and there by monitoring the parameters takes place.

V. HARDWARE IMPLEMENTATION

A. Modules

The module setup consists of two parts, 1. It consists of 5V power supply, RS232 and zigbee. 2. It consists of 12V power supply, sensors, micro controller, driving circuit, relay, zigbee.



Figure 4 Hardware module

Hardware components can be carried over to various places since it is a compact circuit. The module was connected to pc via serial port communication. There by it can monitor the current status of temperature, Co2 and light.

B. Block Diagram

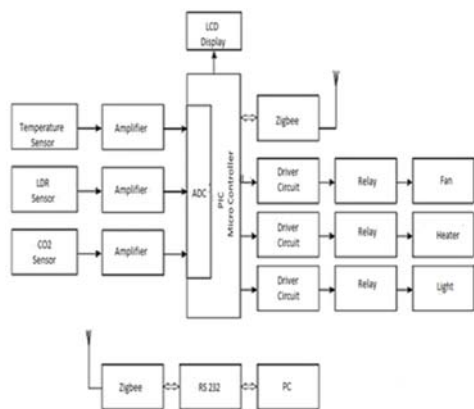

Figure 5 Block diagram

C. Block Diagram Description

Available inputs from various sensors like temperature, LDR, Co2 were given to the amplifier, it is used to amplify the sensors output. From there the output were send to the pic controller were the ADC was inbuilt. Driver circuit was used as a switch for the relay. Relay will control the controller circuit like fan, heater, and light. Zigbee was used as transceiver, RS232 serial communication is to interface the zigbee and pc.

The experiment was setup in the laboratory. The hardware modules consist of two parts, one is interfaced with the pc and the other one was used to monitor. Since zigbee of 5V supply is used for lower power consumption the maximum distance between monitoring circuit and interfacing circuit is 30m. The test results for the

developed system at a moment are shown in table 1. 5 different values had been taken through different location. The acquisition data are sent to control unit by every terminal controller, and then also sent to the PC by the transceiver. The data can be stored, displayed, analyzed, and printed by the software of the PC.

Through pc the temperature set value has been fed as 31°C. In monitoring circuit the thermistor senses the temperature and stored as a received value with the help of visual basic programming the received value and set value was compared, according to first location the temperature was 24.8°C it was less than the set value so the relay will be in off state but for 32.3°C it was greater than set value so the relay get energized and switch on the controller.

Similar as temperature sensor the set value for Co2 was fed as 025 in ppm, according to first location the received value was 003 so the relay will be off for second location the value was 047 so the relay get energized and switch on the exhaust fan.

TABLE 1. Experimental Results

SL.NO	Temperature in (°c)	Concentration of Co2 in (ppm)
1	24.8	003
2	27.5	045
3	32.3	036
4	34.0	012
5	39.9	001

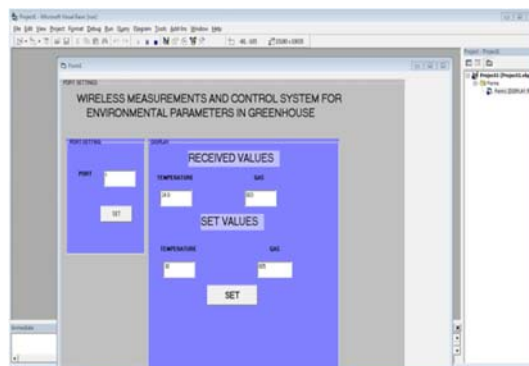

Figure 6 Output for the visual basic program

The brightness of light will be varies according to the usage in the room. If the room needs more brightness then the light will glow more brightly or else the brightness of light will be reduced.

VII. RELATED WORKS

The work of a human plays a major role in olden days they mainly rely on man power, but due to the advancement in technology and rapid growth, science and technology plays an inevitable one. The trend is moving towards wireless solutions due to an increased interest in it as compared to the current wired-based system. SMS technology was developed to monitor and predict changes of temperature level in agricultural greenhouse. The proposed system has a measurement which capable of detecting the level of temperature. This system also has a mechanism to alert farmers regarding the temperature changes in the greenhouse so that early precaution steps can be taken [2]

The main concern from manufacturers of industrial control and building automation systems considering any wireless technology are around robustness and security ZigBee addresses both concerns.

- ZigBee networks are self-healing, rebuilding themselves when nodes drop out of the network and repairing routes when the preferred route for wireless traffic is blocked – something that is very likely to happen in an industrial or commercial building environment over time. Robustness is provided by a powered mesh network providing multiple potential paths for data packets en route to their destination.
- The ZigBee standard includes security on a number of levels, from basic authentication to 128 bit AES encryption, with keys delivered to joining nodes by a trust centre. Security is also enhanced by strict mechanisms for forming, joining and allowing new nodes onto the network when and for how long they will allow nodes to join the ZigBee Coordinator and ZigBee Routers can decide network [4].

The auto control system that collect and automatically control condition of greenhouse environment and crops by using sensor network. The existing control system monitors the temperature and humidity in the green house but, the condition of crops cannot be checked exactly. By using auto control system the conditions of the crops can be checked [6] Automatic control and robotics techniques are incorporated in all the agricultural production levels: planting, production, harvest, post-harvest processes, and transportation. Modern agriculture is subjected to regulations in terms of quality and

environmental impact, and thus it is a field where the application of automatic control techniques has increased substantially during the last years [8], [9]

VIII. CONCLUSION

The measurement and control system for environment parameters based on wireless communication technology is developed and initially experimented. The experimental results show that the developed monitoring system has the following features such as high reliability, good extensibility and flexible configuration. This project illustrates on industrial purpose were the environmental parameters on room can be measured and controlled. The recently developed zigbee wireless has been used.

REFERENCES

- [1] Luis Ruiz-Garcia 1,*, Loredana Lunadei 1, Pilar Barreiro 1 and Jose Ignacio Robla 2 “A Review of Wireless Sensor Technologies and Applications in Agriculture and Food Industry: State of the Art and Current Trends”, Spain.
- [2] Izzatdin Abdul Aziz, Mohd Hilmi Hasan, Mohd Jimmy Ismail, Mazlina Mehat, Nazleeni Samiha Haron ” Remote Monitoring in Agricultural Greenhouse Using Wireless Sensor and Short Message Service (SMS)”, Malaysia.
- [3] D.D.Chaudhary1, S.P.Nayse2, L.M.Waghmare3 “Application Of Wireless Sensor Networks For Greenhouse Parameter Control In Precision Agriculture “, India.
- [4] Archana R. Raut*, Dr. L. G. Malik* ZigBee: The Emerging Technology in BuildingAutomation”, India.
- [5] ZHANG Qian†, YANG Xiang-long†‡, ZHOU Yi-ming, WANG Li-ren, GUO Xi-shan “A wireless solution for greenhouse monitoring and control system based on ZigBee technology*”, China.
- [6] BeomJin Kang, DaeHeon Park, KyungRyung Cho, ChangSun Shin, SungEon Cho, JangWoo Park “A Study on the Greenhouse Auto Control System based on Wireless Sensor Network “Sunchon National University.
- [7] Jin-Shyan Lee, Yu-Wei Su, and Chung-Chou Shen “A Comparative Study of Wireless Protocols: Bluetooth, UWB, ZigBee, and Wi-Fi”, Taiwan.
- [8] Ying Zhang “Design of the node system of wireless sensor network and its application in

digital agriculture” College of Information Engineering, Shanghai Maritime University, Shanghai 200135,China.

[9] Andrzej Pawlowski 1, Jose Luis Guzman 1,*, Francisco Rodríguez 1, Manuel Berenguel 1, José Sánchez 2 and Sebastián Dormido 2” Simulation of Greenhouse Climate Monitoring and Control with Wireless Sensor Network and Event-Based Control”,Spain.

[10] R. Jaichandran ,Dr. A. Anthony Irudhayarj “Prototype System for Monitoring and Computing Greenhouse gases ”, India.

[11] Dr. Mikael Sjödin “Remote Monitoring and Control Using Mobile Phones” Embedded Wireless Information Servers”.

[12] Tao Zheng, Sridhar Radhakrishnan, Venkatesh Sarangan “An adaptive energy-efficient MAC protocol for Wireless Sensor Networks”,Norman.

[13] Muhamad Azman Miskam, Azwan bin Nasirudin, “Preliminary Design on the Development of Wireless Sensor Network for Paddy Rice Cropping Monitoring Application”,Malaysia.

[14] Ning Wang a,, Naiqian Zhang , Maohua Wang “Wireless sensors in agriculture and food industry—Recent development and future perspective”, USA, China.

[15] Anuj Kumar, Abhishek Singh, I. P. Singh, and S. K. Sud “Prototype Greenhouse Environment Monitoring System”, India.