



ANTI-THEFT SECURITY SYSTEM FOR VEHICLES USING EMBEDDED CONTROLLER

Korivi Soumya

Asst.Professor, ECE Dept, St.Martin's Engineering College

Abstract

A capable automobile security system and keeping pace of development in vehicle features with technology have been major concern in automobile industries. A lot of people have to face difficulties in locking/unlocking and switching ON/OFF the car engine upon losing the car key or misplacing the key. Moreover, if a car gets stolen and used for some unlawful activities banned by the government then a car owner will face several legal problems. So to engage in all these issues, an electronic system based on embedded controller is designed and implemented in a real car that does not offer only car security aspects but provides additional features such as unlocking and locking of the car, and switching ON and OFF the car engine vaguely using mobile phone. This paper basically discuss the technological aspects of such electronic system.

Index Terms: Automatic vehicle security system, embedded controller, Global System for Mobile communication, Hardware design.

that the number of cars is growing rapidly and so is the number of car theft attempts, locally and internationally [2]. Although there are a batch of car security systems that had been produced lately, but the result is still unsatisfactory as the number of car theft cases still increases. The thieves are inventing cleverer and stronger stealing techniques that need extra powerful security systems [1].

So, one practicable car security system should be capable, robust and reliable. Many auto theft alarms and devices are installed in cars but they didn't attest to be a solution to the customer's problems. GSM based car/vehicle security system is one of the possible technology solution and it is designed by several groups to identify the car/vehicle location upon getting it stolen. However, the issues in locking/unlocking and switching ON and OFF the car engine upon losing the keyless remote of the car are untouched. . It is quite frequent that a person faces many difficulties in locking and unlocking the car upon losing the keyless remote of the car.

I. INTRODUCTION

As far as vehicle security is concerned many options are available depending upon the technology being adopted. With the development and applications of lots of embedded techniques, car security system design and analyses are continually improving. Many new techniques, such as biometric recognition technique, image processing technique, communication technique and so on, have been included into car security systems. At the same time, the amount of accident of cars still remains high, specially, lost. Statistics show

II. SYSTEM DESIGN

Nowadays crime rate is growing day by day as it is quite clear from the fact that thefts have become a matter of routine. The vehicle thefts particularly cars may cause huge loss on the part of the amount invested on these vehicles. Therefore, the need of the hour is a better anti-theft control system that can be implement by using several technologies like GPS, GSM, GPRS systems. However these systems will offer only the location of the car. In this proposed system it provides additional features such as locking/unlocking the car and

switching ON/OFF car engine. It also provides advantages such as when the car key is missed it helps the user to control the car engine and locking/unlocking the door by just sending an SMS from the user mobile number.

The block diagram shown in Figure 1 completely depict the components involved in the implementation of the embedded security system.

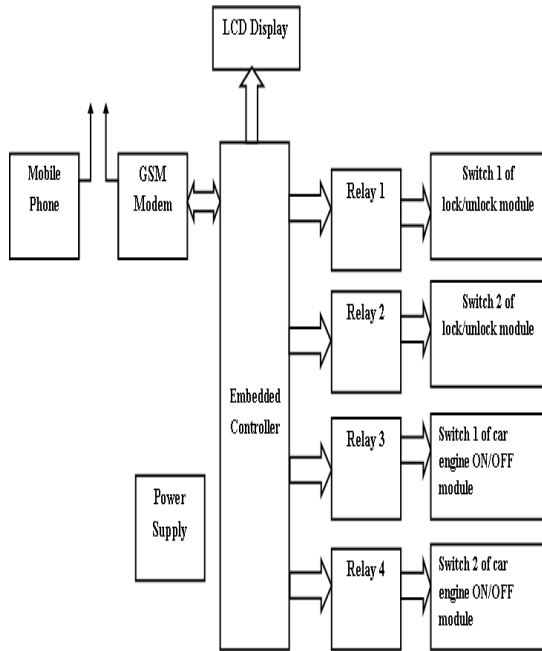

Figure1. Block diagram of vehicle controlled security system

III. PROPOSED SYSTEM

An electronic system proposed in this paper has the following objectives:

- (i) Locking of the car by sending SMS from the user mobile phone to the GSM modem installed in the car.
- (ii) Unlocking of the car by sending SMS from the user mobile phone to the GSM modem installed in the car.
- (iii) Switching ON the car engine by sending SMS from the user mobile phone to the GSM modem installed in the car.

- (iv) Switching OFF the car engine by sending SMS from the user mobile phone to the GSM modem installed in the car.

A. Relay

A relay is electrically operated switch. Lots of relays use an electromagnet to function a switching mechanism mechanically, but other operating principles are also used. Relays are used where it is essential to control a circuit by a low-power signal (with complete electrical isolation between control and controlled circuits), or where several circuits must be controlled by one signal. The first relays are used in extensive distance telegraph circuits, repeating the signal coming in from one circuit and re-transmitting it to another. Relays were used extensively in telephone exchanges and early computers to perform logical operations.

A type of relay that can handle the high power required to directly drive an electric motor is called a contactor. Solid-state relays control power circuits with no moving parts, instead using a semiconductor device to perform switching. Relays with calibrated operating characteristics and sometimes multiple operating coils are used to protect electrical circuits from overload or faults; in modern electric power systems these functions are performed by digital instruments still called "protective relays".

B. Relay driver

The ULN2803A is a huge high-voltage, high-current Darlington transistor array. The device consists of eight NPN Darlington pairs that characteristic high-voltage outputs with common-cathode clamp diodes for switching inductive loads. The collector-current rating of each Darlington pair is 500 mA.

Darlington pairs may be paralleled for higher current capability. Applications comprise relay drivers, hammer drivers, lamp drivers, display drivers (LED and gas discharge), line drivers, and logic buffers. The ULN2803A has a 2.7-kW series base resistor for each Darlington pair for operation directly with TTL or 5-V CMOS devices. The ULN2803A is offered in a standard 18-pin dual in-line (N) package. The device is

characterize for operation over the temperature range of -20°C to 85°C .

C. GSM (Global System for Mobile communication)

The SMS specification has defined a way for a computer to send and receive messages through a mobile phone or a GSM modem. A GSM modem is a wireless modem that operates with GSM wireless networks. This wireless modem transmit the data through the wireless network. To send the SMS messages, first a valid SIM card is located from a wireless carrier into a mobile phone or a GSM modem, which is then connected to the computer. There are several ways of making interface between a computer and a mobile phone. These are through the USB cable, Serial cable, Blue Tooth link or an infrared link. But the definite way to use depends upon the capability of the GSM modem or mobile phone.

If a mobile phone does not support Blue Tooth, it cannot get associated to the computer through the Blue Tooth link. After connecting the mobile or GSM modem, we can control the system by sending the instructions to it that is in the form of messages. The instructions that we give and the messages we receive is fully managed by the software that we are using to control the system. We should write a source code for connecting the mobile to the system and sending and receiving commands to and fro between the GSM modem and the system.

D. PIC microcontroller

Microcontroller is used for broad range of Applications because it is low in cost and easily available. The Microcontroller used in this system is 16F887 operating at a frequency of 20MHz. This PIC acts like analyzer that will analyze a serial signal from machine and generate a PWM (Pulse Width Modulation) pooled with Electronic Speed Controller (ESC) that has high current spec to control high power motor[9].The operating voltage needed to operate this microcontroller range from 2 to 5.5 Volts. It has 35 Input/output pins. It has 256 bytes of EEPROM memory. The data in it can be written about 1,000,000 times. It has 368 bytes

of RAM memory. It has 14 channel A/D converters and 3 independent timers.

This microcontroller is used to run an algorithm and control other peripherals of the system required to position the actuators of the lighting system. Sensor is directed to the microcontroller. Then the Microcontroller identifies the received command and then performs the assigned task PIC 16F887 is one of the most advanced microcontroller from Microchip. This controller is broadly used for experimental and modern applications because of its low price, wide range of applications, high quality, and ease of availability. It is ideal for applications such as machine control applications, measurement devices, study purpose, and so on.

IV. HARDWARE IMPLEMENTATION

Interface of the controller with the output device is shown in Figure 3, LED is associated to the relay in order to find whether the relay is ON/OFF position. Initially the relay is in off position. When the user send the command through SMS the relays are turned ON/OFF according to the command. When the user sends the command the GSM modem acknowledge the received command and display the user phone number and command in the LCD display.

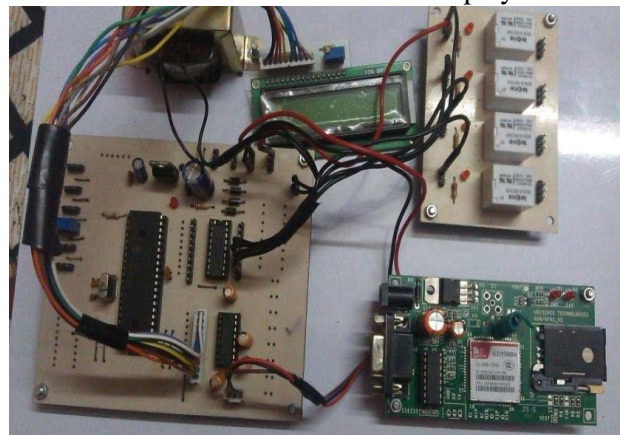

Figure 2 . Hardware implementation of car security system

When the embedded system is initially switched ON the initialization of GSM module is done, which is also displayed in the LCD display shown in below Figure4,



Figure 3. Hardware implementation of car security system LCD initialization

When the user sends the command “RL1ON”, the microcontroller receive the command and in turn it sends logic 1 that switches ON the transistor and energizes the relay corresponding to the unlocking the car will be turned ON. It is indicate by the LED which is also turned ON. This relay can be turned OFF by sending the command “RL1OF” and the LED connected to the relay is also turned OFF.

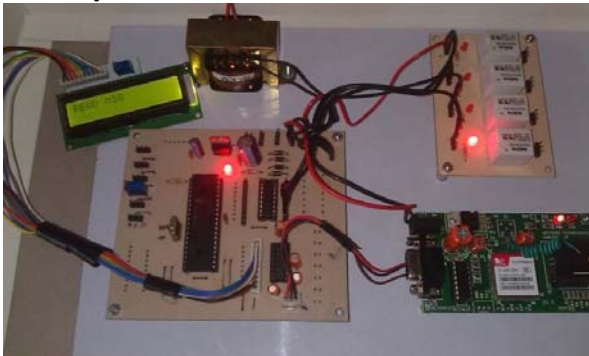

Figure 4. Car security system with relay ON for unlocking the car

IV. CONCLUSION

Vehicle tracking system is fetching increasingly important in large cities and it is more secured than other systems. Now a days vehicle theft is quickly increasing, with this we can have a fine control in it. The vehicle can be turned off by only with a simple SMS. Since, now a days the cost of the vehicles are rising they will not step back to afford it. This setup can be made more interactive by adding a display to show some basic information about the vehicle and also add emergency numbers which can be used in case of crisis. Upgrading this setup is very simple which makes it open to future requirements without the need of rebuilding everything from scratch, which also makes it more competent.

This paper outfit the car security system based on GSM. Earlier security systems designs provide in the car consists of only GPS/GSM modem providing only latitude/longitude location of the car. This paper provides additional features such as locking/unlocking and switching ON/OFF of the car engine. It eliminate the major complaints of the people upon losing a car key by providing an alternative way to control the car using smart phone. System like this can get quite fashionable within a community as it provides more features to the car user at lower cost.

REFERENCES

- [1] R. Ramani, S.Valarmathy, N. Suthanthira Vanitha, S.Selvaraju, M.Thirupathi, and R.Thangam, “Vehicle Tracking and Locking System Based on GSM and GPS,” in *Int. J. of Intelligent Sys. and Appl.*, vol. 5, no. 9, pp. 86-93, Aug. 2013.
- [2] A.K. Mittal and D. Bhandari, “A novel approach to implement green wave system and detection of stolen vehicles,” in *Proc. of Int. conf. on Adv. Comp.*, pp. 1055-1059, 2013.
- [3] R. Venkatesh, G. Ravikanth, and P. Ramu , “Embedded Automated Vehicle Location System ,” in *Int. J. of Research in Comp. and Comm.Tech.*, vol. 2, no. 5, pp. 261-266, May 2013.
- [4] R. Rathiakumar, and D. Manivannan, “Wireless Accident Information System Using GSM and GPS”, *Res. J. of App. Sci., Engg. & Tech.*, vol.18, no. 4, pp. 3323 - 3326, Apr. 2012.
- [5] S. S. Pethakar, N. Srivastava, and S. D. Suryawanshi, “GPS and GSM based Vehicle Tracing and Employee Security System”, *Int. J. of Comp.Appl.*, vol. 62, no. 6, pp. 37-42, Jan. 2013.
- [6] C. VidyaLakshmi and J. R. Balakrishnan, “Traffic Accident Detection through Satellite Navigation System Using GPS Automatically”, in *Proc.Int. conf. on Comp. and Control Engg. ,* pp. 1-4, 2012.