



DESIGN AND IMPLEMENTATION OF OPTIMAL ENERGY MANAGEMENT CONTROLLER FOR THE EFFECTIVE UTILIZATION OF SOLAR POWERED ONLINE- UPS SYSTEM

Dr. M. Karthik¹, T. Chandravadivel², M. Divya³, S.A. Puvarasan⁴

¹Assistant Professor (Sr. G), Department of Electrical and Electronics Engineering, Kongu Engineering College.

^{2,3,4}Scholars of Department of Electrical and Electronics Engineering, Kongu Engineering College.

Abstract

For the effective utilization of Solar Powered Online-UPS System, it requires an Optimal Energy Management Controller. Whenever there is a power demand at times of non-availability of sunlight or at night times, the conventional charge controller automatically charges the battery to its maximum limit and as well supplies the load demand by utilizing the grid power. This leads to the inability of utilizing the solar power effectively for the next day during the time when there is an abundant solar power available. Besides this limitation, the existing solar powered online UPS system faces other two issues such as in delivering the sufficient power demand by the load at times when there is no grid power (Power shut off for maintenance that happens very often) during the day time, the other issue is that the charging method of battery which is usually based on the MPPT charge controller and not according to manufacturer's recommendation which leads to reduction of battery's life. Thus there is a need of an optimal energy management controller to resolve the above said technical obstacles in the solar powered online UPS and henceforth it can be commercialized into the market successfully.

Index Terms: Effective utilization, MPPT Charge Controller, Optimal Energy

Management Controller, Solar Powered Online-UPS System.

I. INTRODUCTION

Solar power is one of the promising renewable energy resources that will surely lead us away from non-renewable energy resources. Building a solar based energy system is cost effective when compared with conventional fossil fuel dependent system. Thus the Solar Powered Online-Uninterrupted Power Supply (UPS) is becoming popular these days. In case of day loads it can be run with relatively lesser solar powered online UPS power with grid disconnected facility ensuring the effective utilization of solar energy. To get rid of the complexity in the existing solar powered online UPS system, an optimal battery management controller will be designed that continuously monitors the grid, solar power availability, battery charging state and the load demand which eventually controls the MPPT charge controller, Inverter and the Battery State of Charge (SoC). The controllers used are Raspberry Pi and Arduino, here the former acts as master and the other acts as slave.

The proposed controller has the additional ability of ascertaining the scheduled shutdown period with the aid of Internet of Things (IoT) technology for the effective power management. This will offer an effective utilization of solar power through the online UPS and paves the way

for delivering the sufficient power demand by the load at times when there is no grid power. This retrofitting leads to the optimal power management for the earlier discussed issues and also enhances the reliability of the system, ensuring the uninterrupted supply of power to the load demand with the effective management of the battery. Hence the motivation of the proposed paper is to design an optimal energy management controller for the effective utilization of solar powered online UPS System with a specific attention given in reducing the grid power usage and energy costs to a great extent.

II. PROBLEMS IN EXISTING SYSTEM

A. Improper utilization of solar energy

In case of the existing Solar Powered Online-UPS System, whenever there is an insufficient power for the load during the night time or when there is an absence of sunlight, the battery charges itself from the grid to its maximum extent. This avoids the utilization of the sunlight during its availability, the efficiency of solar panels are only around 20% and a maximum of 40%, if this energy is also not completely utilized then it leads to further decrease in efficiency. Since the investment cost is also high, the profit is not to the expected limit.

B. Battery charging method

Battery is the key storage element for the solar power, this battery has to be charged according to the manufacturer's recommendation or else it may lead to overheating and frequent battery replacement. The three charging methods of battery are constant current, constant voltage and float charging. The Characteristics of Battery Charging Methods is shown in the fig.1.

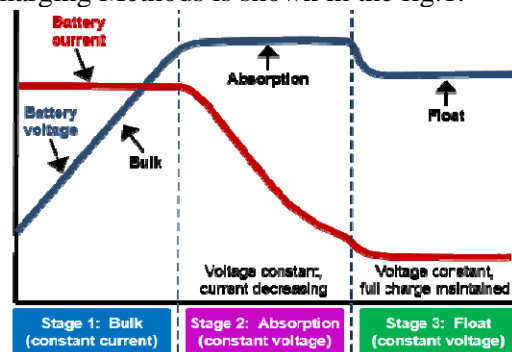

Figure.1. Characteristics of Battery charging Methods

Constant current charging is a method with which the current level set nearly at 10% of rated battery current. Overheating is the effect of improper charging leading to frequent battery replacement. Constant voltage is the method of allowing maximum current to flow into the battery up to the maximum voltage value. After that it remains in float voltage.

C. Power outage

At times of power shutdown, the information may not be sensed by the conventional charge controller. Therefore it may result in insufficient power at times in need of heavy load. In order to overcome these issues, a universal charge controller is proposed.

III. DESIGN FLOW

A. MPPT charge controller

Maximum Power Point Tracker is a type of controller that tracks the maximum power point and confirms that the load receives maximum current and the voltage at which the maximum power is delivered to the loads with minimum losses. The Maximum Power Point indicates the point at which the solar panel generates the largest output i.e. where the product of current intensity and voltage is at peak. The available controller in the market charges the battery with its own specified method of charging and not according to the manufacturer's recommended method of charging.

The designed MPPT Charge Controller consists of a Buck Converter where the battery charging can be controlled in all the three stages i.e. constant current, constant voltage and float charging. Here the designed so called Optimal Energy Management Controller is connected to the MPPT, once the battery model number is given as input to the system; it identifies the recommended charging method from the cloud by the Raspberry Pi controller. The respective information is given to the MPPT and it charges by the battery's desired method of charging. The Circuit Diagram of MPPT Charge Controller is shown in the fig.2.

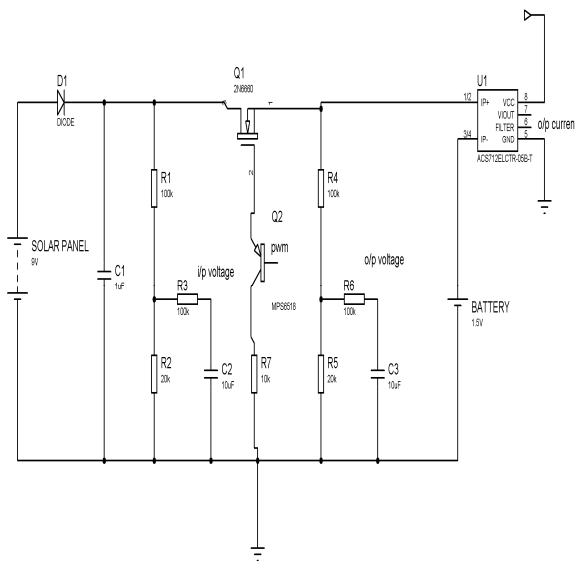

Figure.2. Circuit Diagram of MPPT Charge Controller

B. Energy Management controller

The Block Diagram of Energy Management Controller is shown in the fig.3.

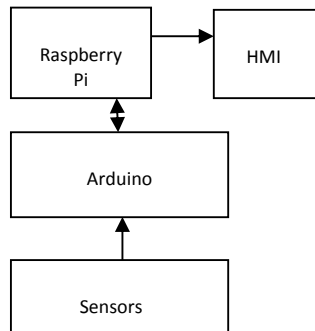

Figure.3. Block Diagram of Energy Management Controller

Here the Raspberry Pi acts as master and the Arduino acts as slave controller. The output from the current and voltage sensors are given to the Arduino which processes and maintains all information. Raspberry Pi is used for fast computation purpose. The Human Machine Interface (HMI) is the touch screen display, where the information such as average load, state of charge is displayed.

C. COMPONENTS DESIGN

Components usage description:
In order to drive IRF9540, $V_{GS(max)} = -20V$

Therefore gate to source resistance = 10K ohms, it is provided in order to limit gate current.

NPN Transistor is used for switching.
Base resistance for transistor = 330 ohms, it is provided in order to limit base current.

Maximum current is 4A, therefore 5A current sensor is chosen.

Arduino needs 5V analog signal, therefore convert 25V in to 5V using voltage divider network.

$$\text{Ratio} = 25V/5V = 5V.$$

Considering leakage current, Resistors of 100K, 20K is chosen. The designed components so far used are shown in the table.I.

Table.I. Designed components

S.NO	COMPONENTS	RATINGS
1.	Solar panel	Maximum output voltage-20V Maximum output current-4A
2.	Fuse	4A
3.	MOSFET P-Channel(IRF9540)	-
4.	Resistor	20K ohms 330 ohms 100K
5.	Current sensor	5A

The components used for rectifying the battery charging problem are mentioned in this tabulation.

IV. PROCESS FLOW

A Solar panel, Battery, MPPT charge controller, 2 Current sensors, Voltage sensor and two different controllers such as Raspberry Pi and Arduino which acts as the heart of the project are the required components.

The Energy meter is connected to the inverter which monitors the daily average load and will continuously updates it to the Raspberry pi which acts as the Master controller and Arduino acts as the Slave controller. During the night time if there is no sufficient solar power to meet out the load then it is detected by the controller

and the state of charge of the battery is maintained. Therefore the power from the grid is taken only for required amount and it does not charges it completely. Thus the solar power in the morning can be utilized effectively. The current sensors are used to indicate the flow of current to the battery and load. The voltage sensor is used to indicate the voltage level.

A machine to machine communication such as IOT/GSM is availed between local distribution station and Prepaid E.B energy meter (expected to be implemented in near future). Therefore it delivers the information regarding the power shutdown finally to the controller. The energy meter has a wireless connectivity with the Raspberry Pi through the wifi chip placed over the energy meter. Based on the information the battery is completely charged and utilized.

The Block Diagram of Optimal Energy Management Controller in a solar powered online-UPS System is shown in the fig.4.

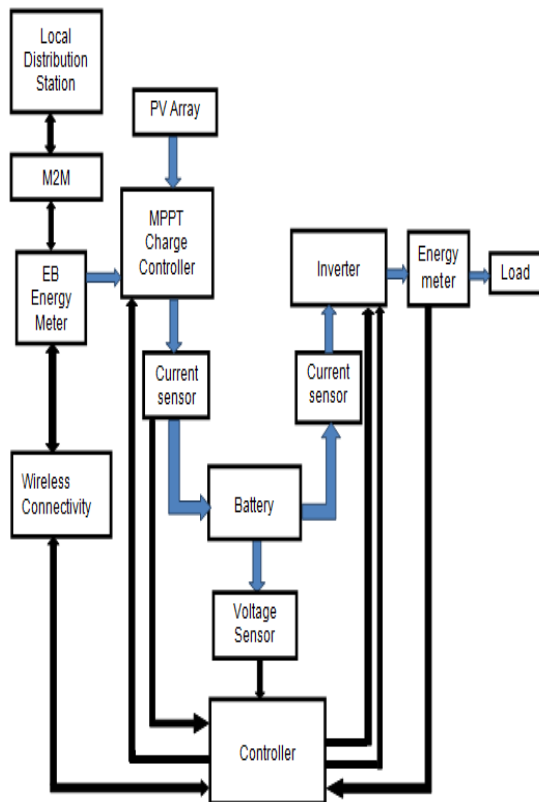

Figure.4. Block Diagram of Optimal Energy Management Controller in a Solar powered Online-UPS System

The Block Diagram of Optimal Energy Management Controller in a solar powered online-UPS System is shown in the fig.5.



Figure.5. Implementation of Optimal Energy Management Controller for rectifying the battery charging problem

The DC output from the solar panel is given to the MPPT charge controller which is a electronic tracker. It provides the maximum power for the battery to be charged but doesn't charge the battery to its specific method of charging. Therefore in our project the battery serial no. is fed to the controller where it searches the details regarding the battery charging method from the cloud and gives it as input to the charge controller. Therefore the charge controller charges the battery with the manufacturer's recommended method. Hence the life of the battery is improved.

V. CONCLUSION

This system is used to improve the life of battery and will increase the charging rate and provides effective utilization of solar power. The technical obstacles present in the Solar Powered Online-UPS system will be resolved and also it will be a cost effective and energy efficient in utilizing the solar power that can be adopted well suitably for the domestic and as well as for the small scale industries where there are frequent power shutdown. The proposed system can be easily configured and it is user friendly.

VI. ACKNOWLEDGEMENT

We are endeavouring immense efforts for this project, yet it would not have been possible without the guidance of many individuals of our Institution. I would like to enlarge my heartfelt thanks to all of them. My gratefulness also goes to my colleague in developing the project and people who have eagerly helped me out with their resourcefulness.

VII. REFERENCES

- [1] Chunjie Hou, Jiabin Wang and Chun Gao, 'Design of Remote Monitoring and Evaluation System for UPS Battery Performance', International Journal of u- and e- Service, Science and Technology Vol.9, No. 5 (2016).
- [2] Hemal Patel, 'Design and Development of Battery charger for Online UPS using Pic Microcontroller', International Journal of Industrial Electronics and Electrical Engineering, ISSN: 2347-6982 Volume-3, Issue-4, April -2015.
- [3] Kanakasabapathy, Vinod kumar Gopal, Abhijith V 'Advancements in Power and Energy (TAP Energy)', International Conference on June 2015.
- [4] Aniruddha Dekate, Pradip Ramchaware (2015) 'Fault Acknowledgement System for UPS using GSM', International Journal of Scientific and Research Publications, Volume 5, Issue 5, May 2015.
- [5] Apiwat Auswamaykin, Boonyang Plangklang (2014) 'Design of Real Time Battery Management Unit for PV-Hybrid System by Application of Coulomb Counting Method', Energy and Power Engineering, 2014, 6, 186-193 Published Online July 2014 in SciRes.
- [6] Nagaraja Naik R, Jayapal.R (2012) 'Design of Online Ups System with Over Voltage, Under Voltage and Phase Out Protection', International Journal of Modern Engineering Research (IJMER) Vol.2, Issue.5, Sep-Oct. 2012.
- [7] S. N. Patil, Sangmeshwar S. Kendre, Dr. R. C. Prasad (2011) 'Battery Monitoring System using Microcontroller', International Journal of Computer Applications (0975 – 8887) Volume 28– No.6, August 2011.
- [8] S.A.Z. Murad, M.N.Md. Isa and N.A. Rahman (2007) 'Monitoring System for Uninterruptible Power Supply', American

Journal of Applied Sciences 4 (3): 177-179, 2007.

[9] S. Cowell, M.A. Morling, New DC power systems for BT (2001) 'Telecommunications Energy Conference', INTELEC 2001. Twenty-Third International, Oct. 2001.

[10]J. Szymborski (1991) 'A high power density lead-acid battery for ups applications, Battery Conference on Applications and Advances', Proceedings of the Sixth Annual, Jan. 1991.