



# MITIGATION OF POWER CAPACITOR SWITCHING TRANSIENTS USING RESISTIVE CAPACITIVE SWITCHING

Dhananjay. S. Sargar<sup>1</sup>, Dr. Sanjay G. Kanade<sup>2</sup>, Soumitra S. Kunte<sup>3</sup>

<sup>1</sup>Assistant Professor, <sup>2</sup>Associate Professor, <sup>3</sup>Assistant Professor

TSSM's Bhivarabai Sawant College of Engineering and Research, Narhe, Pune

## Abstract

**This paper presents the mitigation of power capacitor switching transients using new technique of Resistor and Capacitor switching. Generally, the switching transients are the power quality disturbances that comprise destructive high magnitudes of current and voltage or even both. In case of capacitor switching it may reach thousands of volts and amps even in low voltage systems. However, such phenomena only exist in a very short duration time from less than 50 nanoseconds to as long as 50 milliseconds. Switching transients ordinarily include abnormal frequencies, which could reach to as high as 5 Mega Hertz. When a capacitor bank is switched ON, an unwanted, high frequency inrush current and transient overvoltage may appear during the energizing process. These transients lower the lifetime of the capacitor banks as well as can damage the electromagnetic switches such as circuit breakers in addition to that customer's electrical apparatus might be damaged. To reduce this problem new technique of resistor and capacitor switching can be used to remove this type of power capacitor switching transients. In this paper comprehensive MATLAB simulation of resistor capacitor switching is done for removing capacitor switching transients with improving power factor of the system.**

**Index Terms: Resistor capacitor switching, Transient limiter, PID Controller, Power factor, Power Quality, Power system**

## I. INTRODUCTION

Today's cost of power quality problems is more because increases power sensitive industries requires trouble free power. For the better regulation and use of power supply we connect capacitor banks in the electrical circuit to improve the power factor and reactive power compensation. While doing the switching of this capacitors, switching transients are arises in the power system. In another way, when a capacitor bank is switched on, an unwanted, high frequency inrush current and transient overvoltage may appear during the energizing process. These transients lower the lifetime of the capacitor banks and can damage the electromagnetic switches such as circuit breakers. Customer's electrical apparatus might be damaged during such phenomenon as well. In this context to remove such problems at start of this problem single-DC reactor-type limiter are used. The main drawbacks of such reactor is limiting capability is very poor and charging-discharging modes of the DC reactor result in continuous steady-state power loss [1]. The next solution in case of power factor correction is the new recommendations and Future Standards have increased the interest in power factor correction circuits. There are multiple solutions to this problem to obtain sinusoidal line current and in addition, a great number of circuits have been proposed with non-sinusoidal line current [2]. The Capacitors are prone to two major types of energizing transient phenomenon: transient overvoltage and inrush current (charging current). Energizing transients will shorten the lifetime of the capacitor, and furthermore they will damage the contacts of the switching device. This study

proposes a rectifier type capacitor energizing transient limiter (CETL) for mitigating the isolated capacitor and back-to-back capacitor switch-on transients [3]. The new application of the single-dc reactor-type fault current limiter to suppress the three-phase low-voltage capacitor switching transients [4]. The best solution for this problem is the use of Resistor Capacitor switching transient limiter (RCSTL). The RCSTL is composed of three limiting resistors, a three-phase full bridge diode rectifier, a thyristor and a single-phase coupling transformer. The limiting resistors are connected in series with the capacitor bank and the thyristor is installed at the DC side of the diode rectifier. During the capacitor bank energizing, the thyristor remains off and hence, the secondary side of the coupling transformer acts as open circuit. Consequently, high impedance including the transformer's magnetic reactance in parallel with the limiting resistors. Circuit breakers are inserted in series with the capacitor bank. Under such circumstance, the limiting resistors restrain the capacitor switching transients. In the steady-state, the control system triggers the thyristor and the coupling transformer acts as short circuit. As a result, the limiting resistors are bypassed by the coupling transformer and finally switching transients are gets eliminated.

**II. STRUCTURE AND OPERATION OF RESISTIVE CAPACITOR SWITCHING TRANSIENT LIMITER (RCSTL)**

**A. Structure of Resistive Capacitor Switching Transient Limiter**

The Construction of the Resistive Capacitor Switching Transient Limiter is displayed in Fig. 1. It is composed of a single-phase coupling transformer, a single-phase full bridge diode rectifier, thyristor and single limiting resistors. Single phase coupling transformer is consisting of similar single-phase coupling transformers as primary and secondary with same turn ratio. The limiting resistor is connected in series with the line and shunt with the primary side of the coupling transformer. The rudimentary task of the coupling transformer is to bypass the limiting resistors  $R_L$  in the steady-state condition.

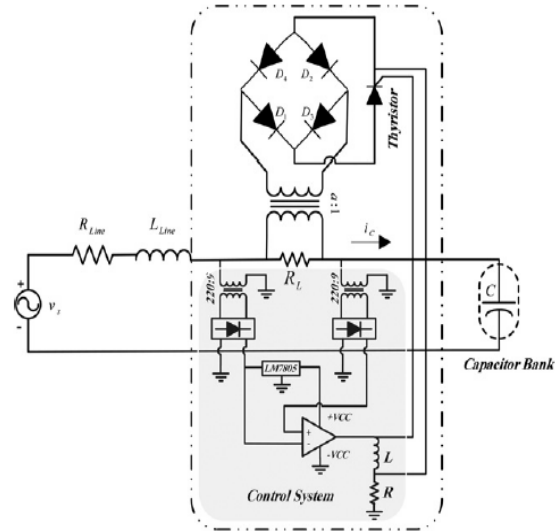

Fig. 1 Single line diagram of RCSTL

**B. Operation of Resistive Capacitor Switching Transient Limiter**

The Resistive Capacitor Switching Transient Limiter operation is distributed into two different situations as: (i) Limiting mode: During the energization process, since the capacitor bank is switched on initial voltage is zero, the positive terminal of the comparator is fewer than the negative terminal. Thus, the output of the comparator is equivalent to  $-VCC$  which is grounded. At this situation, the thyristor is off and the secondary side of the coupling transformer is open. In different way of words, a great impedance of the core magnetizing reactance is imitated to the primary side. Since this impedance is significantly larger than the limiting resistor, the line current flows through the limiting resistor. Therefore, the switching transients are considerably suppressed by the limiting resistor. Fig. 2 shows the Resistive Capacitor Switching Transient Limiter process in the limitation mode.

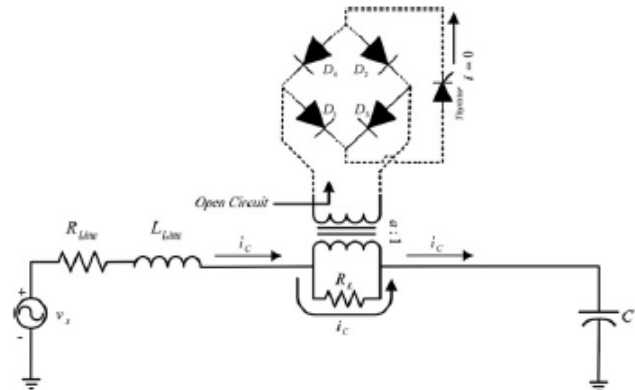

Fig.2 Limiting Mode RCSTL

(ii) Steady-state mode: When the capacitor bank is nearly charged, positive terminal of the comparator is greater than the negative terminal and henceforth, the output of the Op-Amp is equal to +VCC. The L-R circuit directs a pulse to the gate of the thyristor. As a result, the thyristor turns ON and the secondary side of the coupling transformer acts as short-circuits. Thus a little impedance is imitated to the primary side of the coupling transformer. This impedance is appropriate to the leakage inductances and resistances of the primary and the secondary windings of the coupling transformer. This coupling transformer windings are planned to have a little numbers of turns.

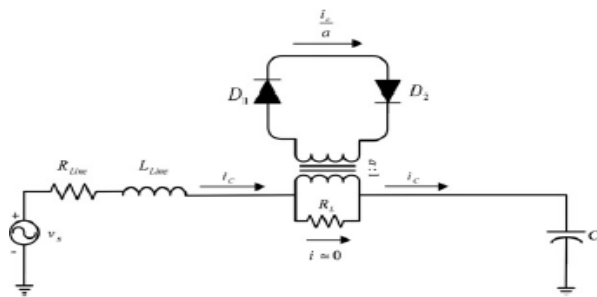

Fig.3 RCSTL in steady state mode

### III. DESIGNING ATTENTIONS

#### A. Full Bridge Diode Rectifier

The bridge rectifier is an arrangement of four or more diodes in a bridge circuit configuration which provides the same output polarity for either input polarity. The primary application of bridge rectifiers is converting an alternating current (AC) input into a direct current (DC). The full bridge rectifier consists of step down transformer, Diode Bridge, voltage regulators and capacitor.

#### B. Coupling Transformer

The heart of this paper is the coupling transformer. The design of this transformer is very crucial in RCSTL. This transformer is designed with the help of MATLAB code by considering input source parameters, load rating and capacitor to switch ON for power factor correction. This transformer generally used to transfer electrical power from a source of alternating current (AC) power to some equipment or device while isolating the powered device from the power source, usually for safety reasons. Isolation transformers provide galvanic isolation and are used to protect against electric shock, to suppress electrical noise in sensitive

devices, or to transfer power between two circuits which must not be connected. A transformer sold for isolation is often built with special insulation between primary and secondary, and is specified to withstand a high voltage between windings. Coupling transformers block transmission of the DC component in signals from one circuit to the other, but allow AC components in signals to pass. Transformers that have a ratio of 1 to 1 between the primary and secondary windings are often used to protect secondary circuits and individuals from electrical shocks between energized conductors and earth ground.

#### C. Limiting Resistor

The performance of the proposed RCSTL essentially relies on the value of the limiting resistors. Indeed, neither too large nor too small values of the limiting resistor are appropriate. When RL is very small, the RCSTL would not offer enough suppression capability. The essential value limiting resistance can be calculated by using following equation.

$$R_L = \frac{V_m - V_0}{I_{Inrush, peak}} \quad (1)$$

In equation (1),  $V_m$  is main voltage source;  $V_0$  is capacitor bank initial voltage.

### IV. MATLAB SIMULATION RESULTS AND DISCUSSION

The MATLAB model of RCSTL simulation consists of voltage source, coupling transformer with limiter resistor, Capacitors to be switched ON, circuit breakers for switching of capacitor, PID controller, Thyristor valve which is triggered by PID controller and diode rectifier bridge. The fig.4 shows the MATLAB simulation of RCSTL for mitigating capacitor switching transients.

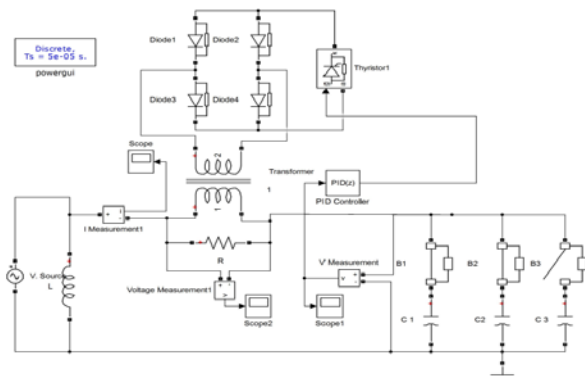

Fig.4 MATLAB Simulation model

Fig.5 shows the current through coupling transformer primary is purely sinusoidal having magnitude of 2 Amperes. This due to switching of resistor and capacitor using PID controller. Fig. 6 shows current through limiting resistor which is again purely sinusoidal because of switching of resistor and capacitor using PID controller. This current has magnitude of again 2 amperes. The fig. 7 shows the voltage across capacitor banks, which have the very high spike at the starting instant because of capacitor switching. These capacitors are switched ON for the improving power factor and reactive power compensation. This voltage has spike at starting and having magnitude up to the 1000 volts and then reduces to normal single phase 230 volts supply. The fig.8 shows the voltage across capacitor which have no spikes throughout waveform and having magnitude 230 volts purely sinusoidal.

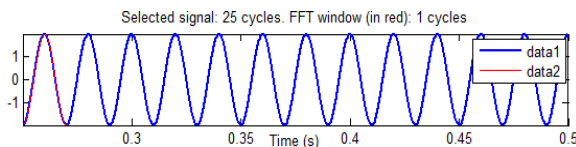

Fig. 5 Current through coupling transformer primary with RCSTL

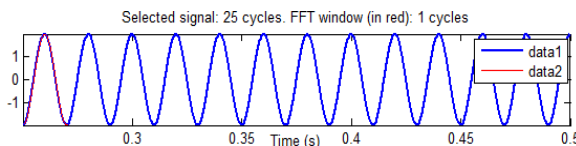

Fig.6 Current through limiting resistor with RCSTL

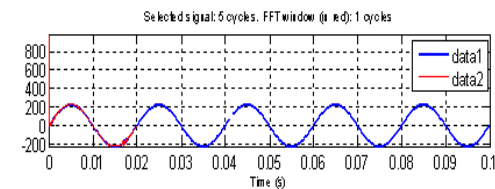

Fig. 7 Voltage across capacitor bank without RCSTL

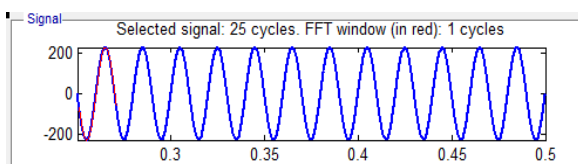

Fig. 8 Voltage across capacitor bank using RCSTL

## V. CONCLUSION

To diminish the switching transients of power capacitor bank, the single resistive capacitor switching transient limiter that is RCSTL is presented. During the energization process, the RCSTL mitigates the switching transients by utilizing three limiting resistors in series with the capacitor bank with the help of coupling transformer, rectifier bridge and thyristor valve with PID controller. In the steady-state, the secondary side of the coupling transformer is turned on and hence, the limiting resistors are bypassed by means of the coupling transformer. Agreeing to the simulation results, it can be concluded that the projected RCSTL is able to considerably remove the energizing transients.

## REFERENCES

- [1] Teymoor Ghanbari et al. "Three-phase resistive capacitor switching transient limiter for mitigating power capacitor switching transients," IET Generation, Transmission & Distribution, pp. 1-12, The Institution of Engineering and Technology 2015
- [2] Miller, T.J.E.: 'Reactive power control in electric system' (John Wiley and Sons, Inc. Press, 1982), pp. 204–214
- [3] Garcia, O., Cobos, J.A., Prieto, R., et al.: 'Power factor correction: A survey'. IEEE Proc., PESC, 2001, pp. 8–13
- [4] Blooming, T.M., Carnovale, D.J.: 'Capacitor application issues', IEEE Trans. Ind. Appl., 44, (4), pp. 1013–1026
- [5] Skeans, D.W.: 'Recent development in capacitor switching transient reduction'. Proc. T&D World Expo. Substation Section, pp. 1–13
- [6] Chandwani, H., Upadhyay, C.D., Vahora, A., et al.: 'Mitigation of switching overvoltage by application of surge arrester on capacitor bank', J. Electr. Engery Tech., 2013, pp. 37–45
- [7] Smith, L.M.: 'A practical approach in substation in substation capacitor bank applications to calculating, limiting, and reducing the effects of transients currents', IEEE Trans. Ind. Appl., 1995, 31, (4), pp. 721–72.