



ELECTRO MAGNETIC PISTON

Gadi Karthik¹, V.Upender²

^{1,2}Mechanical Engineering, Indur Inst of Engineering and Technology, Siddipet, India

Abstract

I have invented the Magnetic Repulsion Piston Engine, to substitute the internal combustion piston engine, The IC engines work by burning fuel and creating an explosion that forces the pistons down, consequently, emitting over a billion tons of Co₂ into our atmosphere That is why it is essential we find solutions to the noise, pollution, and health hazard caused by the IC engine. With the Magnetic Repulsion Piston Engine, internal combustion is substituted by a magnetic field which depends on a primary energy source of a 12 Volt battery and the results shows that when the delay time between the two pistons is decreasing, the rpm of crank is increasing and also the break power is increasing.

Keywords: Cylinder with copper winding, Stainless steel rods, wooden crank wheel, Crankshaft, Connecting rod, PCB circuit.

I. Introduction

An I.C engine converts chemical energy into mechanical energy. In some engines, pistons deliver this mechanical energy. The engines in which the combustion of fuel takes place inside the engine cylinder are called internal combustion engines (briefly written as I.C. engines). The working pressure and temperature inside the cylinder of I.C. engine is very high. The efficiency of I.C. engines is about 35-45 percent.

We know that the I.C. engine will work with the burning of the fossil fuel (with the burning of the fuel that will cause the environmental pollution). The cost of the fuel is much. This fuel is non-renewable source. May be in future the availability of the fuel is not possible.

Internal combustion engines generate undesirable emissions during the combustion

process. In this, both SI and CI engines are equally responsible for the same. The emissions exhausted into the surroundings pollute the atmosphere and causes the following problems Global warming, acid rain, smog, odors, respiratory and other health hazards.

The major causes of these emissions are non-stoichiometric combustion, dissociation of nitrogen. Of nitrogen (NO_x), oxides of sulphur (SO_x), and solid carbon particulates.

It is the dream of engineers and scientists to develop engines and fuels such that very few quantity of harmful emissions are generated, and these could be let into the surroundings without a major impact on the environment.

So, to control all problems of I.C. engine, we are replacing the electromagnetic piston engine in the place of I.C. engine. Here we are using the I.C. engine technology, but in the place of fuel we are using the electromagnetic field as a source with the electromagnetic field we are getting the reciprocating movement of the piston so, then without using of any fuel there is no chance of any pollution. When compare to the I.C. engine the power losses are very less in electromagnetic piston engine.

A. Electromagnetic field

An electromagnetic field (also EMF or EM field) is a physical field produced by moving electrically charged objects. It affects the behavior of charged objects in the vicinity of the field. The electromagnetic field extends indefinitely throughout space and describes the electromagnetic interaction. It is one of the four fundamental forces of nature (the others are gravitation, the weak interaction, and the strong interaction).

The field can be viewed as the combination of an electric field and a magnetic field. The electric field is produced by stationary charges, and the magnetic field by moving charges (currents);

these two are often described as the sources of the field. The way in which charges and currents interact with the electromagnetic field. The electromagnetic field can be regarded as a smooth, continuous field, propagated in a wavelike manner.

B. Engine Components

We have taken the PVC pipe and cutted it with the help of hacksaw frame. The length of the PVC pipe is 10cm and the diameter is 12 mm. and to the PVC pipe the copper wire is winded. The length of copper wire is 50 m and thickness is 0.8mm. This arrangement is called cylinder. For this cylinder the upper part is closed with the rubber and down part is open.

Piston: We have taken the stainless steel rod and cutted with the help of haxa frame. The length of the rod is 16 cm and the diameter is 8 mm. this arrangement is called piston. **Connecting rod:** We have taken the wood and cutted the length of 16.5 cm and the thickness is 8mm this arrangement is called connect rod

Crank wheel: Wooden crank We have taken the wood the diameter is 120 mm and thickness is 18 mm the arrangement is called crank wheel.

Crank shaft:

we have taken the stainless steel rod the diameter is 5 mm the offset(length) is 10 cm and it is welded with gas welding this arrangement is called crank shaft.

Supports:

We have taken wood for the base and supporting rods (wood). Number of rods we have taken is 4 – 6.

Brake load: We have taken the cloth and cutted into required length and shape for the belt we have arranged. The belt one side fixed and another side to vary load. Loads act at center of the wheel is 9 cm

Balancing Cylinders: Straight-two engine, (also straight twin, parallel twin, inline twin, or vertical twin) is a two-cylinder piston engine that has its cylinders arranged side by side. There are three crankshaft configurations for this engine: 360°, 180°, and the new 270°:

- In a 360° engine, both pistons rise and fall together. The dynamic balance is identical to that of a single-cylinder engine.
- In a 180° engine, one piston rises as the other falls. This gives good primary balance.

- In a 270° engine, one piston follows a quarter of a turn behind the other. This is a compromise between the first two types, yielding results similar to a V-twin.

Bearings: We taken stainless steel material the model no of bearing is 626z the number of bearings we have used is 4.S

C. PCB circuit:

MICROCONTROLLER AT89S52
VOLTAGE REGULATOR 7805
CRYSTAL OSILLATOR
MOS FET 1RF540
MECHANICAL REGULATOR

A printed circuit board, or PCB, is used to mechanically support and electrically connect electronic components using conductive pathways, tracks or signal traces etched from copper sheets laminated onto a non-conductive substrate. It is also referred to as printed wiring board (PWB) or etched wiring board. A PCB populated with electronic components is a printed circuit assembly (PCA), also known as a printed circuit board assembly or PCB Assembly (PCBA). Printed circuit boards are used in virtually all but the simplest commercially produced electronic devices.

Alternatives to PCBs include wire wrap and point-to-point construction. PCBs are often less expensive and more reliable than these alternatives, though they require more layout effort and higher initial cost. PCBs are much cheaper and faster for high-volume production since production and soldering of PCBs can be done by automated equipment. Much of the electronics industry's PCB design, assembly, and quality control needs are set by standards that are published by the IPC organization. The AT89S52 is a low-power, high-performance CMOS 8-bit microcontroller with 8K bytes of in-system programmable Flash memory. The device is manufactured using Atmel's high-density nonvolatile memory technology and is compatible with the industry-standard 80C51 instruction set and pin out. The on-chip Flash allows the program memory to be reprogrammed in-system or by a conventional nonvolatile memory pro-grammar. By combining a versatile 8-bit CPU with in-system programmable Flash on a monolithic chip, the Atmel AT89S52 is a

powerful microcontroller which provides a highly-flexible and cost-effective solution to many embedded control applications. The AT89S52 provides the following standard features: 8K bytes of Flash, 256 bytes of RAM, 32 I/O lines, Watchdog timer, two data pointers, three 16-bit timer/counters, a six-vector two-level interrupt architecture, a full duplex serial port, on-chip oscillator, and clock circuitry. In addition, the AT89S52 is designed with static logic for operation down to zero frequency and supports two software selectable power saving modes. The Idle Mode stops the CPU while allowing the RAM, timer/counters, serial port, and interrupt system to continue functioning. The Power-down mode saves the RAM contents but freezes the oscillator, disabling all other chip functions until the next interrupt or hardware reset. 8-bit Microcontroller with 8K Bytes In-System Programmable Flash AT89S52 1919D

D. Mechanical Regulator

It consists of five steps they are connected to microcontroller pins i.e., 1, 2,3,4,5 respectively. Regulator regulate the speed of the engine .it is placed on the PCB board.

II Load testing

For testing the engine at the load condition we have arrange the belt to the wooden wheel. One end of the belt is fixed and the other end is at open condition for applying the loads. For this testing we will get the torque and break power of the engine. When the engine is in running position we may add a little amount of weight and take the readings which are required for the calculations. Now increasing the weights gradually and note down all of the readings. At a certain point when the weights are over loaded the wheel will stop the running. That is the break point of the engine.

III Working

We are replacing the electromagnetic piston engine in the place of IC engine. By this replacement we are eliminating the environmental pollution. Here we can take 12 volts DC battery as input .This battery is connected to PCB circuit. In this PCB circuit we are using micro controller , power supply unit , mechanical regulator. In microcontroller embedded C-language program is dumped. This engine works based on this program. The PCB circuit is connected to cylinder with copper winding.

When the power is supplied to the coils the electromagnetic field will generate inside the cylinder tube alternatively. Here we can arrange inline twin cylinders. With the electromagnetic field first piston is attracted upward direction and the second piston is in off mode. Then after the second piston is attracted upward the first one is in off mode. Both of these pistons are moving alternatively with one and another one. The pistons are connected with the connecting rods and the connecting rods are connected to crankshaft. With the alternating moment of the pistons the crankshaft will rotates the flywheel. i.e., the mechanical output By using the mechanical regulator.

A. Equations

Input power= $V \times I$ W

Output power= $V \times I$ W

Where, V=voltage, I=current (Ah).

Torque (T) = $(P \times 60) / (2\pi N)$ Nm

Where, P =output power (W) N=rpm
(Or)

$T = w \times l$ Nm

Where, w=load (N) l=moment arm (m)

Break power= $(2\pi NT) / (60)$ W

T=torque (Nm), N=rpm

Efficiency(η)=(output)/(input)

B.Figures and Tables

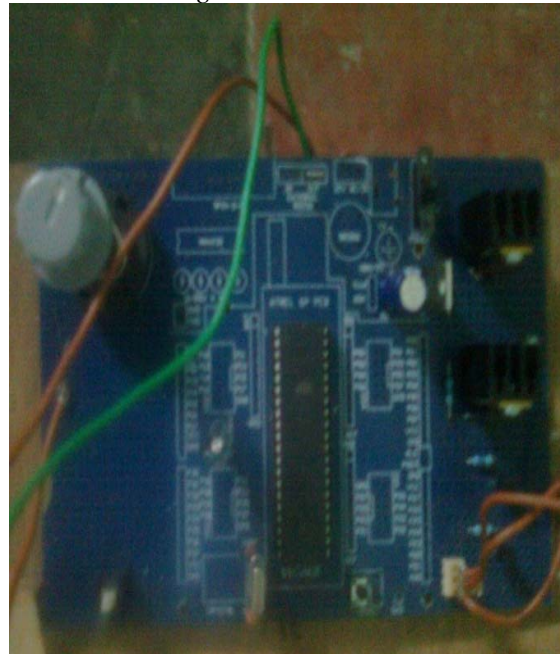

Fig.1. MICROCONTROLLER AT89S52

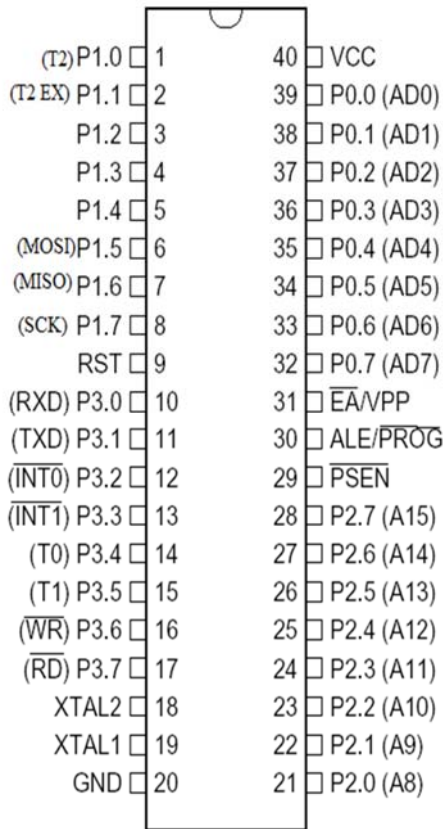

Fig.2.PCB circuit

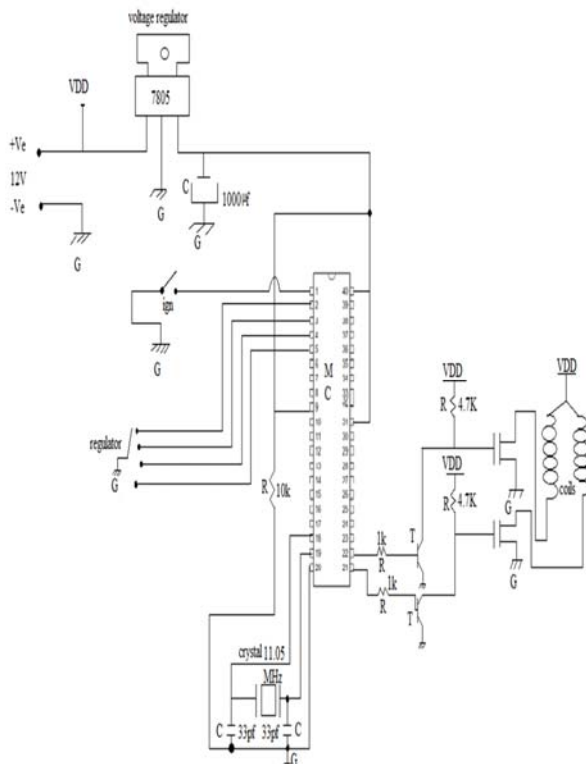

Fig. 3. MICROCONTROLLER AT89S52

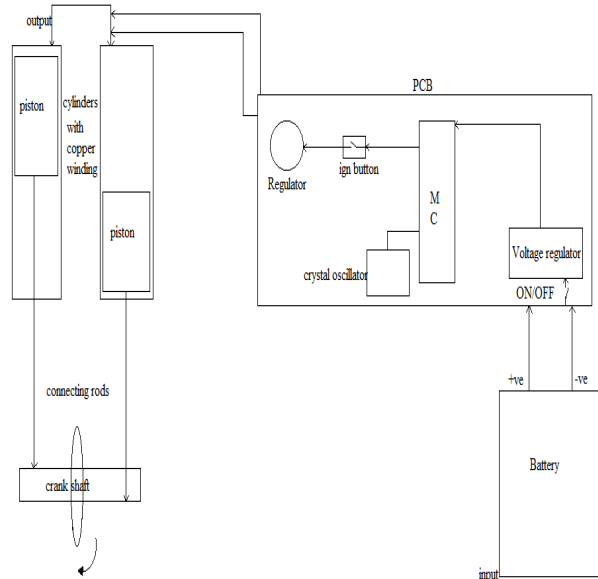

Fig.4.ENGINE WORKING DIAGRAM

TABLE 1

Regulator steps	Delay time in sec	Rpm	B.P. in W
1	0.03	450	1.27
2	0.026	840	2.37
3	0.023	1650	4.66
4	0.0195	2000	5.6
5	0.016	2300	6.49

Input =108 W, $l=0.09$ m
 Output =92 W, load (w) =30gm=0.027N
 $\eta=85.18\%$, torque= 0.027 Nm

TABLE 2

Regulator steps	Delay time in sec	rpm	B.P. in W
1	0.03	380	1.78
2	0.026	680	3.2
3	0.023	1000	4.71
4	0.0195	1250	5.88
5	0.016	1600	7.5

Input =108 W, $l=0.09$ m
 Output =96 W, load (w) =50gm=0.509N
 $\eta=88\%$, torque= 0.045 Nm

Regulator steps	Delay time in sec	rpm	B.P. in W
1	0.03	180	1.71
2	0.026	300	2.85
3	0.023	550	5.225
4	0.0195	680	6.46
5	0.016	800	7.6

Input =108 W, $l=0.09$ m

Output =100 W, load (w) =100gm=1.01N

$\eta=93\%$, torque= 0.09 Nm

Analysis

The above table shows that when the delay time between the two pistons is decreasing, the rpm of crank is increasing and also the break power is increasing.

C. Merits

1. Here we are not using any fuel, so that there is no environmental pollution that is environmental pollution is zero percentage.
2. Maintenance cost is less.
3. Noise pollution is very less
4. The power drops are less
5. If there is a any problem generated in this engine, repairing of this engine is very easy compare to IC engine.
6. It is an eco friendly engine.

D. Demerits

1. To recharge the battery external source is required.
2. The engine will works for only sufficient weights
3. Providing protection for the cylinders are must need.

IV Conclusion

Now a day we are facing increasing price of the fuel. The effect of burning fossil fuel is obvious and up to now no effort has been made to control the diversification effect it has on the environment. Let us solve these lots of problem for manufacturers with our simple and logical invention without them designing a "new type" of engine (electromagnetic piston) to replace the "classic type". However, some simple inexpensive modification will be made to the conventional type making it feasible, thereby keeping tradition.

We may avoid the environmental pollution. If we can develop this technology we have lots of uses of this technology in future.

References

- [1] www.8052.com/tutorial.phtml
- [2] www.physicsforums.com Engineering > Mechanical Engineering
- [3] [peswiki.com/index.php/Directory: Engines 8051](http://peswiki.com/index.php/Directory:Engines8051)
- [4] Micro controller by Kenneth J Ayala