



REVIEW AND ANALYSIS OF DISTRIBUTED POWER FLOW CONTROLLER (DPFC) - A NEW FACTS DEVICE

Sandesh Shete¹, Pavan Pohekar², Dhananjay Sargar³

¹Assistant Professor, Department of EE, TSSM' BSCOER, Narhe, Pune

²Assistant Professor, Department of EE, Govt. college of Engg., Nagpur

³Assistant Professor, Department of EE, TSSM' BSCOER, Narhe, Pune

Abstract

This paper presents a new Flexible AC Transmission system (FACTS) device as distributed power flow controller (DPFC). The aim of the paper is to introduce a new type of power- flow controlling device that offers the same controlling capability as the UPFC, at a reduced cost and with increased reliability. The new device is the further advancement in the UPFC. DPFC is derived from unified-power flow controller (UPFC) & DPFC has the same control capabilities as that of UPFC like impedance control. The DPFC can be considered as (UPFC) with an eliminated common dc link. The active power exchange between the shunt and series converters, which is through the common dc link in the UPFC, is now through the transmission lines at the third -harmonic frequency. The principle and interaction between the DPFC, the network and machines are analyzed.

Index Terms: FACTS, Power flow controlling devices, UPFC, DPFC, Modeling, power transmission, Power Flow Control, Power electronic devices.

I. INTRODUCTION

The growing demand ageing of networks make it desirable to control the power flow in power transmission system fast and reliably. The flexible ac transmission system (FACTS) technology is the application of power electronics in transmission system. Currently, the unified power flow controller (UPFC) shown in Fig.1 is the most powerful FACTS device which can simultaneously control all the parameters of the system: The line impedance, the transmission angle and the bus voltage. The

UPFC is the combination of static synchronous compensator (STATCOM) and static synchronous series compensator (SSSC), which are coupled via a common dc link, to allow bidirectional flow of active power between the series output terminals of the SSSC and the shunt output terminals of the STATCOM.

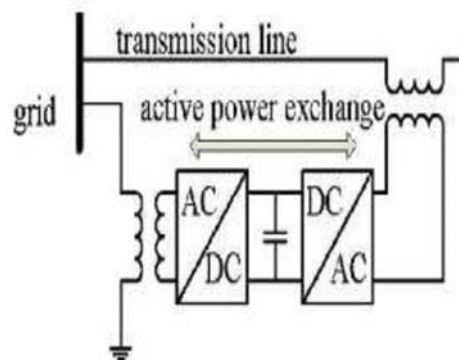

Fig.1 Simplified representation of a UPFC

The converter in series with the line provides the main function of the UPFC by injecting a four-quadrant voltage with controllable magnitude and phase. The injected voltage essentially acts as a synchronous ac- voltage source, which is used to vary transmission angle and line impedance, thereby independently controlling the active and reactive power flow through the line. (The two converters operated from a common DC link provided by a DC storage capacitor. The UPFC is not widely applied in practice due to their high cost and redundancy to failure. Since the components of the UPFC handle the voltages and current with high rating, therefore the total cost of the system is high. Due to the common DC link interconnection a failure that happens at one converter will influence the whole system. To achieve the required reliability

for power systems, bypass circuit or redundant backups are needed which leads to increase the cost. The same as the UPFC, the Distributed Power Flow Controller (DPFC) recently presented in is a power flow device within the FACTS family, which provides much lower cost and higher reliability than the conventional FACTS devices. It is derived from the UPFC and has the same capability of simultaneously adjusting all the parameters of power system like line impedances, transmission angle and bus voltage magnitude. The DPFC Flow chart and configuration are shown in Fig.2 and Fig.3 respectively

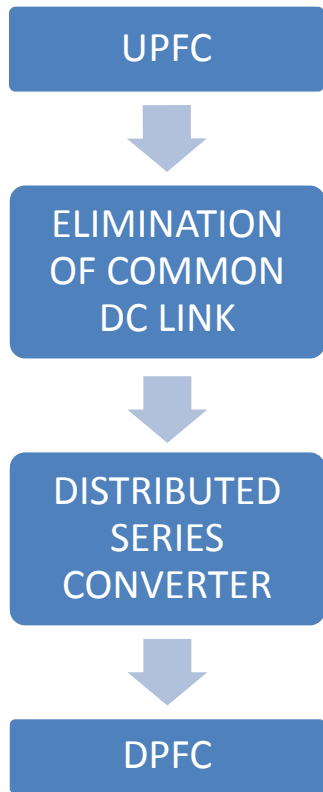

Fig. 2 Flow chart from UPFC to DPFC

II. DPFC OPERATING PRINCIPLE

The DPFC consists of one shunt and several series connected converters. The shunt converter is similar as a STATCOM, while the series converter employs the DFACTS concept, which is to use multiple single-phase converters instead of one large rated converter. Each converter within the DPFC is independent and has its own dc capacitor to provide the required dc voltage. The configuration of the DPFC is shown in Fig. 3. As shown, besides the key components, namely the shunt and series converters, the DPFC also requires a high-pass filter that is shunt

connected at the other side of the transmission line, and two Y-Δ transformers at each side of the line. To ensure that the DPFC have the same control capability as the UPFC, a method that allows the exchange of active power between converters with eliminated dc link is the prerequisite.

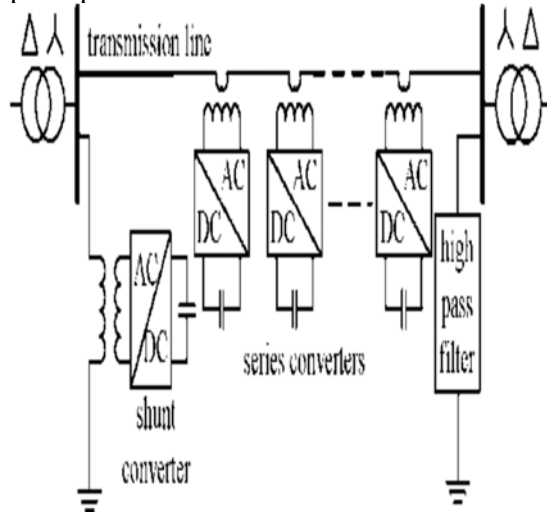

Fig3. DPFC Configuration

A. ELIMINATE DC LINK

Within the DPFC, transmission line is the common connection between the AC terminal of the shunt and series converters. Therefore it is possible to exchange the active power through the terminals of the converters. The method is based on power theory of non-sinusoidal components. According to the Fourier analysis, a non-sinusoidal voltage and current can be expressed by the sum of sinusoidal functions in different frequencies with different amplitudes. The active power resulting from this non sinusoidal voltage and current is defined as the mean value of the product of voltage and current. Since the integral of all the cross product of terms with different frequencies are zero, the power can be expressed by:

$$P = \sum_{i=1}^{\infty} V_i I_i \cos \phi$$

Where V_i and I_i are the voltage and current at the i th harmonic frequency, respectively, and ϕ_i is the corresponding angle between the voltage and current. From this equation active power at different frequencies is isolated from each other and voltage or current in one frequency has no influence on active power at other frequencies. The independency of the active power at different frequencies gives the possibility that a

converter without power source can generate active power at one frequency and absorb this power from other frequencies. By applying this method to the DPFC the shunt converter can absorb the active power from the grid at the fundamental frequency and inject the current back into the grid at a harmonic frequency. Due to unique features of 3rd harmonic frequency components in a three phase system, the 3rd harmonic is selected for active power exchange. In a three phase system the 3rd harmonic each phase is identical, which means they are zero sequence components. Because the zero sequence harmonic can be naturally blocked by star delta transformers and these are widely incorporated in power systems, there is no extra filter required to prevent harmonic leakage. Fig.4 shows Active power exchange between DPFC converters.

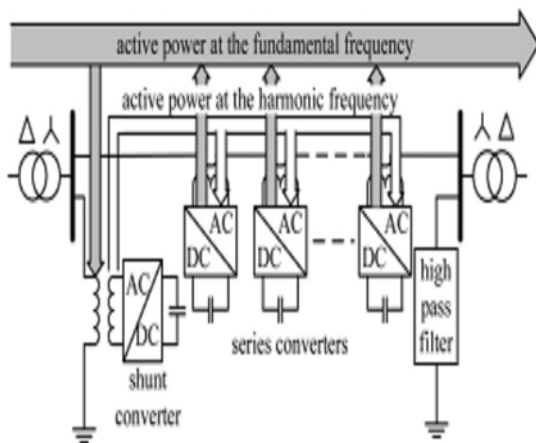

Fig. 4 Active power exchange between DPFC converters

B. Distributed Series Converter

The D-FACTS is a solution for the series connected FACTS, which can dramatically reduce the total cost and increase the reliability of the series FACTS device. The idea of the D-FACTS is to use a large number of controllers with low rating instead of one large rated controller. The small controller is a single-phase converter attached to transmission lines by a single-turn transformer. The converters are hanging on the line so that no costly high-voltage isolation is required. The single-turn transformer uses the transmission line as the secondary winding, inserting controllable impedance into the line directly. Each D-FACTS module is self-

powered from the line and controlled remotely by wireless or power line communication shown in Fig.5. The structure of the DFACTS results in low cost and high re-liability. As DFACTS units are single-phase devices floating on lines, high-voltage isolations between phases are avoided. The unit can easily be applied at any transmission voltage level, because it does not require supporting phase ground isolation. The power and voltage rating of each unit is relatively small. Further, the units are clamped on transmission lines, and therefore, no land is required. The redundancy of the D-FACTS provides an uninterrupted operation during a single module failure, thereby giving a much higher reliability than other FACTS devices.

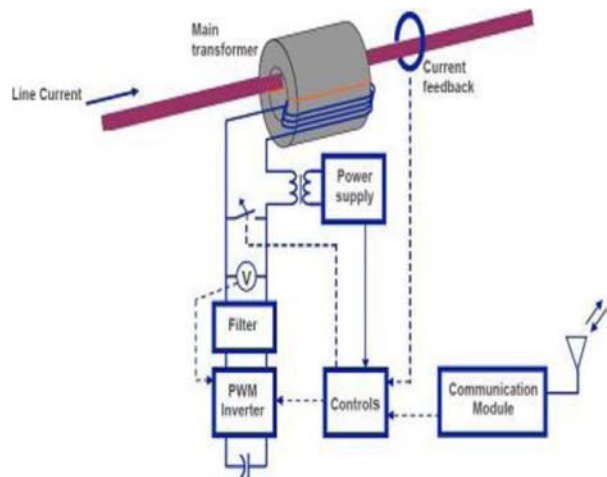

Fig. 5 D-facts Concept

C. Advantages of DPFC

The DPFC can be considered as a UPFC that employs the DFACTS concept and the concept of exchanging power advantages of the UPFC and the D-FACTS, which are as follows.

1. High control capability: The DPFC can simultaneously control all the parameters of the power system: the line impedance, the transmission angle, and the bus voltage.
2. High reliability: The redundancy of the series converter gives an improved reliability. In addition, the shunt and series converters are independent, and the failure at one place will not influence the other converters. When a failure occurs in the series converter, the converter will be short-circuited by bypass protection, thereby having little influence to the network.

- Low cost: There is no phase-to-phase voltage isolation required by the series converter. Also, the power rating of each converter is small and can be easily produced in series production lines.

III. DPFC CONTROL

To control the multiple converters, DPFC consists of three types of controllers; they are central controller, shunt control, and series control, as shown in Fig. 6. The shunt and series control are local controllers and are responsible for maintaining their own converters' parameters. The central control takes account of the DPFC functions at the power system level. The function of each controller is listed next.

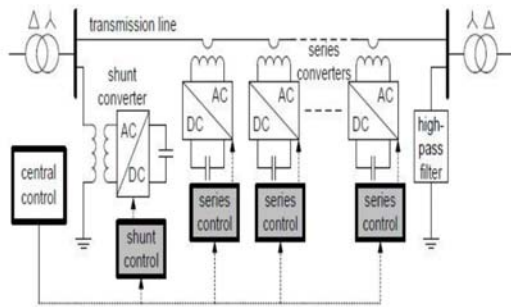

Fig. 6 DPFC control block diagram

A. Central Control

The central control generates the reference signals for both the shunt and series converters of the DPFC. It is focused on the DPFC tasks at the power-system level, such as power flow control, low-frequency power oscillation damping, and balancing of asymmetrical components. According to the system requirement, the central control gives corresponding voltage reference signals for the series converters and reactive current signal for the shunt converter. All the reference signals generated by the central control are at the fundamental frequency.

B. Series control

Each series converter has its own series control. The controller is used to maintain the capacitor DC voltage of its own converter, by using 3rd harmonic frequency own converter, by using 3rd harmonic frequency components, in addition to generating series voltage at the fundamental frequency as required by the central control

C. Shunt control

The objective of the shunt control is to inject a constant 3rd harmonic current into the line to supply active power for the series converters. At the same time, it maintains the capacitor DC voltage of the shunt converter at a constant value by absorbing active power from the grid at the fundamental frequency and injecting the required reactive current at the fundamental frequency into the grid.

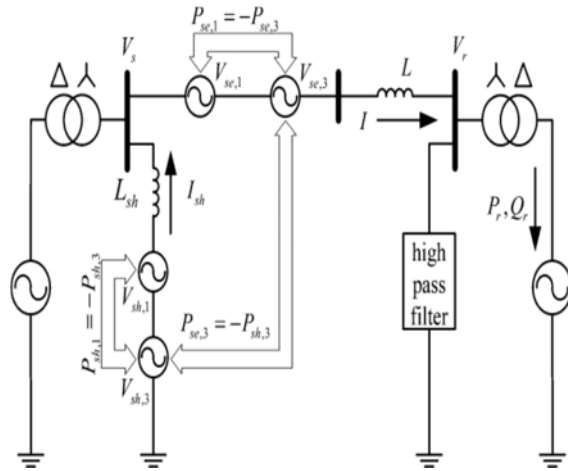

Fig.7. DPFC equivalent circuit: (a) the fundamental frequency;

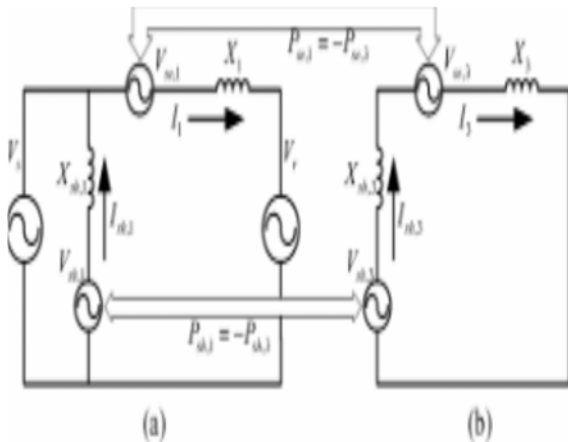

Fig.7. DPFC equivalent circuit: (b) the 3rd harmonic frequency.

IV CONCLUSION

The DPFC emerges from the UPFC and inherits the control capability of the UPFC, which is the simultaneous adjustment of the line impedance, the transmission angle, and the bus voltage magnitude. The common dc link between the shunt and series converters, which is used for exchanging active power in the UPFC, is eliminated. This power is now transmitted

through the transmission line at the third-harmonic frequency. The total cost of the DPFC is also much lower than the UPFC, because no high-voltage isolation is required at the series-converter part and the rating of the components is low. From above it is proved that the shunt and series converters in the DPFC can exchange active power at the third-harmonic frequency, and the series converters are able to inject controllable active and reactive power at the fundamental frequency.

REFERENCES

- [1] Z. Yuan, S. W. H. de Haan, and B. Ferreira, "Distributed power flow controller (DPFC) and Applications, 2007 European Conference on, 2007.
- [2] Zhihui Yuan, Sjoerd W.H.de Haan, J Braham Ferreira and Dalibor Cvoric "A FACTS Device: Distributed Power Flow Controller(DPFC)" IEEE Transactions Power Electronics, vol. 25, no.10, October 2010.
- [3] M. D. Deepak, E. B. William, S. S. Robert, K. Bill, W. G. Randal, T. B. Dale, R. I. Michael, and S. G. Ian, "compensator system for realizing active power flow control on existing power lines" IEEE Trans. Power Del., vol. 22 Jan. 2007.
- [4] Zhihui Yuan, Sjoerd W.H de Haan and Braham Ferreira "control during shunt converter failure Electronics 2009.
- [5] Z. Yuan, S. W. H. de Haan, and B. Ferreira, "Power Flow Controller (DPFC) for Power Oscillation Damping IEEE Power and Energy Society General Meeting 2009.
- [6] Z. Yuan, S. W. H. de Haan, and B. Ferreira, "Result of a Scaled Transmission System with the Distributed Power Flow Controller (DPFC)" European Conference on Power Electronics and Applications (EPE) 2009.
- [7] Z. Yuan, S. W. H. de Haan, and B. Ferreira, "Improve DPFC Performance during Series Converter Failures Power and Energy Society General Meeting (PESGM) 2010, Minneapolis, USA.
- [8] Sarimalla Pedakotaiah and Santosh A "power-flow controller (DPFC) Journal of Engineering and Science, Vol. 2,jan. 2013.
- [9] Praveena and M. Mahendran "The compensatation of unbalanced 3 phase currents in transmission systems on utilize distributed power flow controller" IJRET Apr. 2013.
- [10] P. Ramesh and M. Damodara Reddy "reliability improvement in a transmission line using distributed power- flow controller" International Computer Engineering (IJECE), Vol.2, Aug. 2012.
- [11] A.Jamshidi, S. Masoud Barakati, and M.M.Ghahderijani "quality improvement and mitigation case study using distributed power flow controller" IEEE Industrial Electronics,2012