



## PADDY STRAW BRIQUETTING

Prof. S. Chandrasekar<sup>1</sup>, R.Haridevi<sup>2</sup>, L. Harini<sup>3</sup>, K.S.Jaganath<sup>4</sup>

<sup>1</sup>Assistant Professor, Department of Electrical and Electronics Engineering,  
Kongu Engineering College.

<sup>2,3,4</sup>Final year Students of Department of Electrical and Electronics Engineering,  
Kongu Engineering ,College.

### ABSTRACT

**Abundant paddy straw is thrown as waste after harvesting time. With a very minimal wealth, this paddy waste could be a good source of income. It's completely Eco-friendly green energy project. It saves the global environment, and to produce green energy. This project is to produce the material as briquettes, which is made from the wastage like Paddy straw or the cattle wastage. Here in our work, paddy straw is mixed with paper binder to form briquettes. These briquettes and energy source for cooking purpose and in some industries like bricks and bakery.**

### I.INTRODUCTION

Every year, most of the farmers in Punjab and Haryana set fire the crop residues. After the paddy harvesting is over, they have to prepare the crop fields quickly for wheat and other Rabi season crops. This cropping pattern leads to the burning of paddy straw (stubble) which emits large amounts of gases including smog-forming carbon monoxide, carbon dioxide, nitrogen dioxide etc.

The thick smoke which spread out as a result of setting fields on fire leads to serious health hazards for people. Burning fields also affects the quality of the soil, steals its vital nutrients. The generated toxic smoke causes respiratory problems and other diseases.

Every year, around Mega tonnes of paddy residue causes total emissions due to paddy burning across India. The change in air quality is especially unpleasant for the elderly, children, and people with recurring respiratory conditions.

### II.PROBLEM STATEMENT

From the captured images of NASA Satellites, the active burning and fires spanning areas are more than 250kms from east to west, which even obscured the satellite view of Delhi during stubble-burning months of October-November. The substantial increase in the Air Quality Index (AQI) of Delhi exceeding a particulate concentration of 300-400 during these months, including most days of November, provides further evidence of the impact of stubble burning.

Apart from the environmental impact, stubble burning has been found to cause serious health hazards in Punjab and Haryana. A recent study says that “people in rural Punjab have to spend RS. 7.6crore every year on treatments for ailments caused by stubble burning”. The importance of the issue has been acknowledged by governments in Punjab and Haryana. However stubble burning is still practiced by many farmers as it is inexpensive and time efficient.

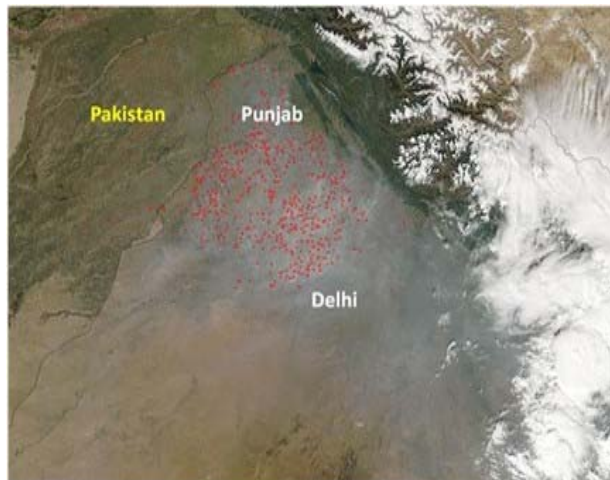

**Figure.1**

III. LITERATURE SURVEY

Every year about 12 million tonnes of paddy straw is burned in Punjab. According to O P Rupela, former soil microbiologist at the International Crops Research Institute for the Semi-Arid Tropics (ICRISAT), this leads to nutrient loss from the soil which is equivalent to US \$18 million worth of urea. Rupela, along with scientists from Punjab Agricultural University (PAU), has developed a simple and rapid composting technique to convert huge piles of paddy straw into organically rich soil. It takes about 45 days to prepare this paddy straw compost which helps conserve nitrogen and other nutrients contained in the straw, he says. The compost contains 1.7 to 2.1 per cent of nitrogen, 1.5 per cent phosphorous and 1.4 to 1.6 per cent potassium. It helps improve crop yield by 4 to 9 per cent. "But the problem was that farmers found it labour-intensive," says the soil scientist. A PAU scientist, who does not wish to be named, agrees with Rupela. "The problem with Punjab farmers is they want quick solutions. That is why the paddy straw compost was not adopted in our state as well as in neighbouring Haryana." Rupela offers another use of paddy straw—mulching. In this method, straw is spread across the soil surface and allowed to decompose naturally into the soil by the activity of worm and other organisms. "A few farmers in Punjab have adopted it. Farmers in Andhra Pradesh, another paddy growing state, have also resorted to this method as it helps maintain soil fertility," says Rupela, adding that crops like pigeon pea, soybean and maize are easily grown even with mulch on surface.

S Y Mehta, plant head of PBPL, says, "A 12 MW paddy-straw power plant typically needs 120,000 tonnes of stubble, which can be collected from about 15,000 farmers." Power sector pundits say that energy demand may increase by 50 per cent by 2030 and, as Mehta says, power production from paddy straw is a promising way to meet the demand. If enough biomass power plants are set up, it will provide a new source of income to farmers, he adds. But the power industry pays less to farmers than the packaging industry. Mehta says paper and packaging industry needs straw in small amounts and hence are spoiling the market (see 'What industry pays'). "Our straw requirement is 350 to 400 tonnes a day. We pay about RS 900 a tonne for non-basmati paddy straw and Rs 1,500 for

basmati straw as it has high calorific value," Mehta says, adding that paddy straw may increase in the future as the market becomes competitive. With several applications, it seems farmers have no lack of options for handling the agro-waste in a profitable way.

With continuous burning of paddy fields, Delhi's air quality is deteriorating. Data collected from October 30 to November 2 shows that there has been a continuous rise in the Air Quality Index (AQI) of the city. The more the AQI rises, the more people are likely to suffer from adverse health impacts. The monitored value of AQI from October 30 to November 2 ranges from 201 to 297 which fall under the "Very Unhealthy" category.

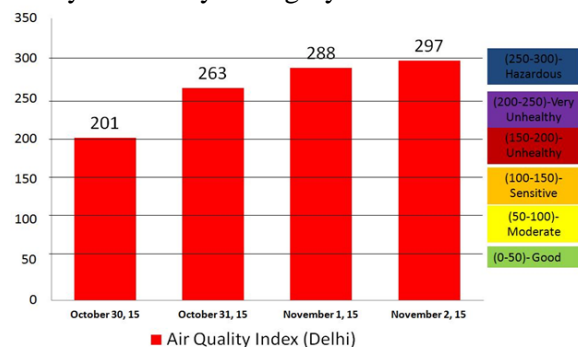

Figure.2

Source: US Embassy data calculated as per Indian standards by SAFAR, MOES-IITM-IMD

Punjab and Haryana are both responsible for causing air pollution due to burning. These two states contribute to 48 per cent of the total emission due to paddy burning across India. Burning of crop residues emits traces of carbon dioxide, methane, carbon monoxide, nitrous oxide, sulphur dioxide and particulates which affect human health.

IV. TECHNICAL DESCRIPTION  
BLOCK DIAGRAM

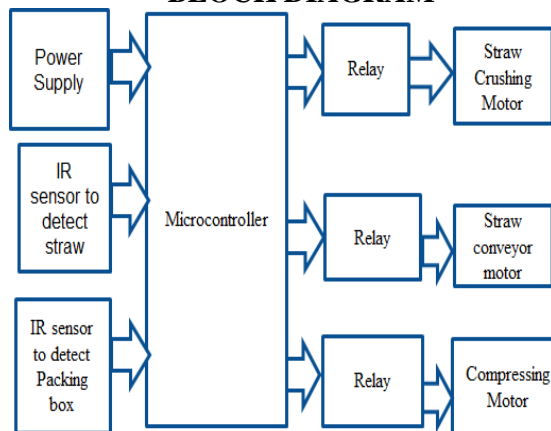

Figure.3

## INFRARED SENSOR

An infrared sensor measures the IR light that is transmitted in the environment to identify the objects by an IR LED. The infrared sensor have usage navigation purpose for object avoidance, distance Measurement or line following applications. This sensor is very sensitive to IR lights and sunlight, and this is the main reason that an IR sensor is used with great precision in spaces.

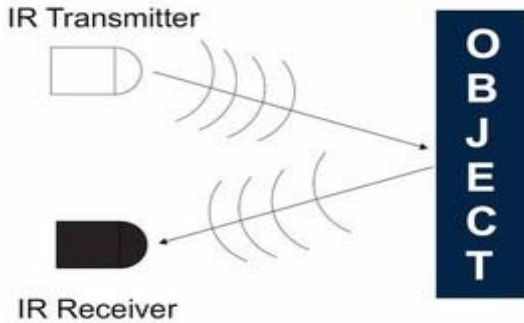

Figure.4

Advantages of Infrared sensors

- Infrared sensors can detect infrared light over a large area
- They can operate in real-time
- The IR sensor uses non-visible light for detection

Disadvantages of Infrared sensors

- This sensor is very sensitive to IR lights and sunlight
- It has a weakness to darker colours such as black

## DC MOTOR

A DC motor is a class of rotary electrical machine that convert electrical power into mechanical power. The most common types rely on the forces produced by magnetic fields. Mostly all types of DC motors have some internal mechanism, either electro mechanical or electronic to periodically change the direction of current flow in part of the motor. These are the more traditional type of motor and are typically used in cost-sensitive applications, where the control system is simple, such as in consumer applications.

- **Series Wound** – In this type, the field winding is connected in series with rotor winding and speed control is by varying the supply voltage, however this type offers poor speed control and as the torque to the motor increase, then the speed falls.

- **Applications** include automotive, hoists, lifts and cranes as it has a high starting torque.

## RELAY

A relay is an electrically operated switch. Many relays use an electromagnet to mechanically operate as a switch. Relays are used where it is necessary to control a circuit by a separate low-power signal, or where several circuits must be controlled by one signal. At first relays were used in long distance telegraph circuits as amplifiers: they repeated the signal coming from a one circuit and re-transmitted it on another circuit. Relays were used extensively in telephone exchanges and early computers to perform logical operations.

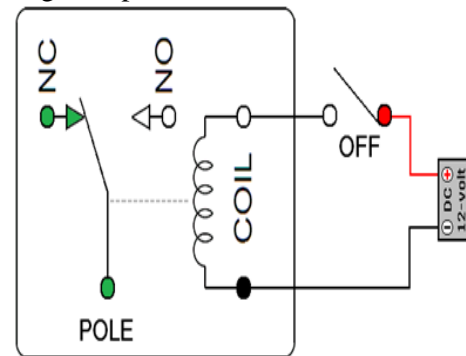

Figure.5

A type of relay that can handle the high power required to directly control the electric motor or other loads is called a contactor. Solid-state relays control power circuits with no moving parts, instead using a semiconductor device to perform switching. Relays with multiple operating coils are sometimes used to protect electrical circuits from overload or faults in modern electric power systems.

## TRANSFORMER

A transformer is an electrical device that transfers electrical energy between two or more circuits through electromagnetic induction. A current varying in one coil of the transformer produces a varying magnetic field, which in turn induces a varying electromotive force (emf) or "voltage" in another coil. Power can be transferred between the two coils through the magnetic field, without a metallic connection between the two circuits. Transformers are used to increase or decrease the alternating voltages in electric power applications.

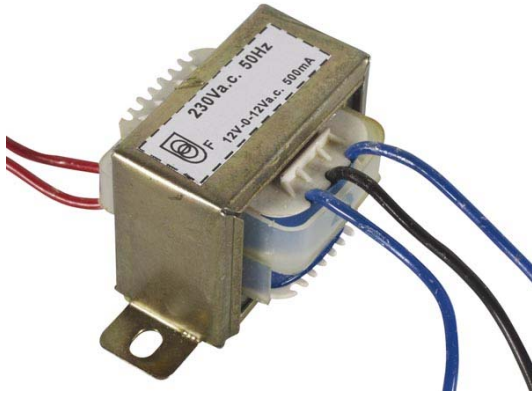

Figure.6

**MICROCONTROLLER**

The ATmega8 is a low-power CMOS 8-bit microcontroller based on the AVR RISC architecture. By executing powerful instructions in a single clock cycle, the ATmega8 achieves throughputs approaching 1 MIPS per MHz, allowing the system designed to optimize power consumption versus processing speed.

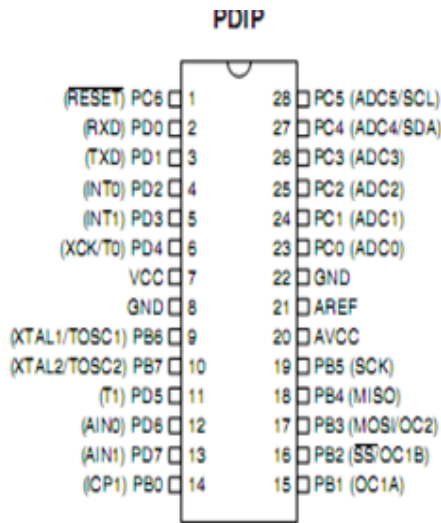

Figure.7

- High-performance, Low-power AVR 8-bit Microcontroller
- Advanced RISC Architecture
- High Endurance Non-volatile Memory segments
- Peripheral Features
- Special Microcontroller Features
- I/O and Packages

**Operating Voltages**

- – 2.7 - 5.5V (ATmega8L)

**Speed Grades**

- – 0 - 8 MHz (ATmega8L)
- – 0 - 16 MHz (ATmega8)
- Power Consumption at 4 MHz, 3V, 25°C

**V.MECHANICAL SETUP**



Figure.8

- The paddy straw and paste is fed into the mixture which is driven by an ac motor.
- After a certain time, the mixed content is then fed into the conveyor belt.
- The conveyor belt accumulates the mixed content with the blocking plate.
- After segregation of a mixture to a particular level, the compressing plates compress the mixture.
- The compressed mound will be released from the blocking plate and fell down from the conveyor.

**VI.ELECTRICAL SETUP**

➤ DRIVER CIRCUIT:

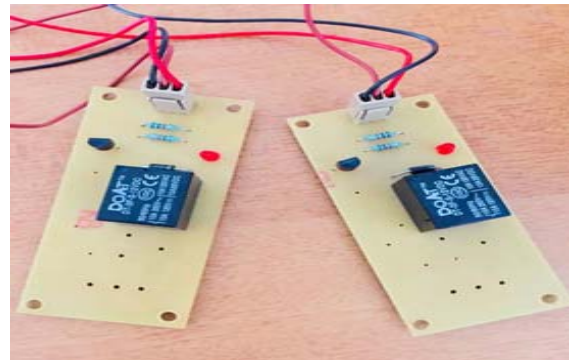

Figure.9

➤ SUPPLY CIRCUIT:

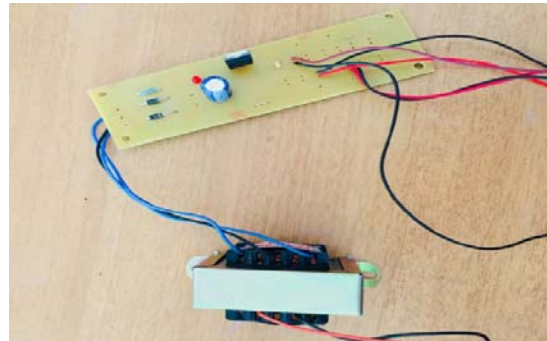

Figure.10

## ➤ CONTROL CIRCUIT:

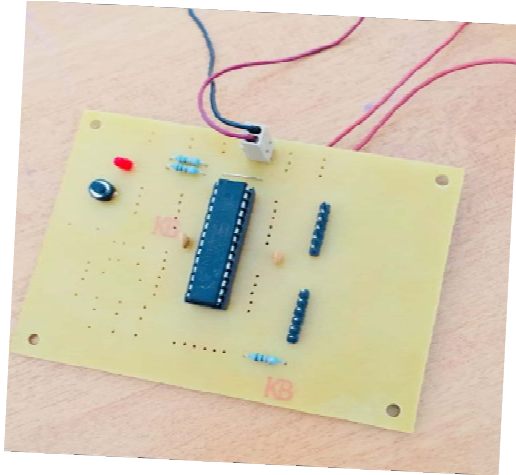

Figure.11

## VII.CONCLUSION

This project acts as “Best from waste”. The wastage from these sources is raw material of the project and the finished product is called Briquettes. Briquettes are made from agricultural waste, which can effectively, used as substitute of solid fuel [wood] and can easily use various kinds of thermal applications.

## REFERENCES:

- [1] R. Poda **Potential applications of paddy husk ash waste from paddy husk biomass power plant** *Renew. Sustain. Energy Rev.*, 53 (2016), pp. 1468-1485, [10.1016/j.rser.2015.09.051](https://doi.org/10.1016/j.rser.2015.09.051)
- [2] J. Lim, Z. Abdul Manan, S.R. Wan Alwi, H. Hashim **A review on utilization of biomass from paddy industry as a source of renewable energy** *Renew. Sustain. Energy Rev.*, 16 (5) (2012), pp. 3084-3094, [10.1016/j.rser.2012.02.051](https://doi.org/10.1016/j.rser.2012.02.051)
- [3] Y. Li, X. Ding, Y. Guo, C. Rong, L. Wang, Y. Qu, X. Ma, Z. Wang **A new method of comprehensive utilization of paddy husk** *J. Hazard Mater.*, 186 (2011), pp. 2151-2156, [10.1016/j.jhazmat.2011.01.013](https://doi.org/10.1016/j.jhazmat.2011.01.013)
- [4] M.K.D. Rambo, A.L. Cardoso, D.B. Bevilaqua, T.M. Rizzetti, L.A. Ramos, G.H. Korndorfer, A.F. Martins **Silica from paddy husk ash as an additive for paddy plant** *J. Agron.*, 10 (2011), pp. 99-104, [10.3923/ja.2011.99.104](https://doi.org/10.3923/ja.2011.99.104)
- [5] Z. Liu, X. Liu, B. Fei, Z. Jiang, Z. Cai, Y. Yu **The properties of pellets from mixing bamboo and paddy straw** *Renew. Energy*, 55 (2013), pp. 1-5, [10.1016/j.renene.2012.12.014](https://doi.org/10.1016/j.renene.2012.12.014)
- [6] C.S. Chou, S.H. Lin, W.C. Lu **Preparation and characterization of solid biomass fuel made from paddy straw and paddy bran** *Fuel Process. Technol.*, 90 (7) (2009), pp. 980-987, [10.1016/j.fuproc.2009.04.012](https://doi.org/10.1016/j.fuproc.2009.04.012)
- [7] K.G. Mansaray, A.E. Ghaly **Physical and thermochemical properties of paddy husk** *Energy Source*, 19 (9) (1997), pp. 989-1004, [10.1080/00908319708908904](https://doi.org/10.1080/00908319708908904)
- [8] J. Werther, M. Saenger, E.U. Hartge, T. Ogada, Z. Siagi **Combustion of agricultural residues** *Prog. Energy Combust. Sci.*, 26 (1) (2000), pp. 1-27, [10.1016/S0360-1285\(99\)00005-2](https://doi.org/10.1016/S0360-1285(99)00005-2)
- [9] F.R. Kargbo, J. Xing, Y. Zhang **Property analysis and pre-treatment of paddy straw for energy use in grain drying: a review** *Agric. Biol. J. N. Am.*, 1 (2010), pp. 195-200
- [10] P. Binod, R. Sindhu, R.R. Singhanian, S. Vikram, L. Devi, S. Nagalakshmi, A. Pandey **Bioethanol production from paddy straw: an overview** *Bioresour. Technol.*, 101 (13) (2010), pp. 4767-4774, [10.1016/j.biortech.2009.10.079](https://doi.org/10.1016/j.biortech.2009.10.079)
- [11] M.K. Delivand, M. Barz, S.H. Gheewala **Logistics cost analysis of paddy straw for biomass power generation in Thailand** *Energy*, 36 (3) (2011), pp. 1435-1441, [10.1016/j.energy.2011.01.026](https://doi.org/10.1016/j.energy.2011.01.026)