



# ROLE OF POWER ELECTRONIC DEVICES AND APPLICATIONS IN AEROSPACE TECHNOLOGY

S Nazeer Ahmed<sup>1</sup>, Gopala Venu Madhav<sup>2</sup>

<sup>1</sup>8<sup>th</sup> semester, Department of Electrical and Electronics Engineering  
Anurag Group of Institutions, Hyderabad

<sup>2</sup>Professor, Department of EEE, Anurag Group of Institutions

## Abstract

The use of power electronics devices in space science and technology has become a widespread in all over the world. Basically, power electronics is the application of solid-state electronics used for the purpose of control and conversion of electric power. Even the satellites and space shuttle require electrical power. In this paper, role of Power Electronic Devices in internal power station, satellite power system, motor drives, generators/starters and reusable launch vehicles, flywheels, servos for electromechanical actuation and spacecraft on-board electric propulsion (thrusters, electrical energy used to change the velocity of a space craft) is presented. Using of power electronics devices on-board (spacecraft) is incompatible because of the variable frequency of the Shuttle itself and is about 400Hz.

**Keywords:** Power station, satellite power system, motor drives and on-board electric propulsion.

## I. THE POWER ELECTRONIC SYSTEM

The Power Electronic System consists of a modular Power electronic subsystem (PESS). PESS is also called as a smart power device, power control module. Both source and load are connected at input and output ports. The third port is connected to a control system. Figure 1 represents PESS.

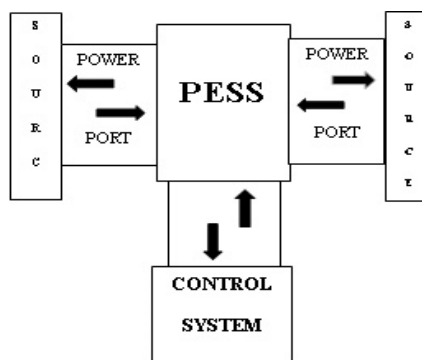

Fig. 1. Block diagram.

## II. POWER SEMI-CONDUCTOR DEVICES

Metal-Oxide semi-conductor field effect transistor (MOSFET), Insulated gate bi-polar transistor (IGBT), Silicon controlled rectifier (SCR), Gate turn-off thyristor (GTO) all these are semi-conductor devices and also the power converters which plays a prominent role in technological development. They are controlled devices. Their application depends on the power and frequency characteristics.

Voltage controlled MOSFET's are much preferable than other types of MOSFET, as it is relatively fast and also requires less protection (snubbing) as it has low switching losses. It can be used in the applications of range about few MHz and few watts to few Kilo watts.

IGBT requires minimum cooling and experiences low voltage spikes during turn off and when used in 0 to 300KVA, 1.5 to 5 KHz voltage-source Inverter (PWM). It is more reliable.

GTO can be turned on/off by giving gate current pulses. It has high switching losses for that a snubber circuit is provided to protect from the voltage surges.

### III. POWER ELECTRONIC CONVERTERS

Aerospace power systems have a considerable real estate of DC power usage. Over the past decade, AC power has emerged as a 'driver' for developing MET's. This has increased the use of power electronic converters to condition and control power in the related systems. Aerospace power systems have a considerable real estate of DC power usage. Over the past decade, AC power has emerged as a 'driver' for developing MET's. This has increased the use of power electronic converters to condition and control power in the related systems. The snubbered converter employs switching similar to that of the PWM. It incorporates a series inductive snubber to limit the inrush-current through its devices. A parallel capacitive snubber limits the device voltage, and reduces device stress. High switching losses are dissipated in the snubber. The zero-current switching (ZCS) converter uses an inductive snubber for device turn-off without current flow. Similarly, the zero-voltage switching (ZVS) converter employs a capacitive snubber for device turn-on, with an anti-parallel diode conducting. The converters have high switching frequency, lossless devices, high efficiency and reliability. The Resonant DC-Link (RDCL) and Resonant AC Link converters overcome the limitations of PWM. The RDCL converter has low switching losses, heat dissipation and acoustic noise, higher operating frequency and reliability, and reduced  $dv/dt$  and  $di/dt$ , resulting in low electromagnetic interference. DC-DC converters have been used in aerospace power systems to provide the required voltage for the secondary distribution network. The basic topologies are the step-down (buck) and step-up (boost) converters for various load requirements. For a given input voltage, the average output voltage is obtained by switching the electronic devices at constant frequency, while adjusting the device 'ON' duration. Electronic converters constitute the heart of motor drives which are essential for electromechanical actuation.

### IV. MOTOR DRIVE TECHNOLOGIES

The electric motor is the workhorse in a drive system. Drive characteristics depend on the motor, the power circuit, electronic devices and the controller. Power rating, operating speed range, environment, fault tolerance, reliability, performance, thermal capability and cost affect

motor selection for an application. In the past, the excellent drive performance and low initial cost of DC machines made them the primary choice for servo applications. Their built-in commutators, high maintenance and spark-inducing brushes hinder DC machine use in drives. "Brushless" motors have emerged from coupling DC, AC synchronous and induction motors with electronic controllers. The resulting maintenance- and spark-free brushless DC machine (BLDCM) or permanent magnet synchronous motor (PMSM), switched reluctance motor (SRM) and induction motor (IM) have higher torque/inertia ratio, peak torque capability, power density and reliability than the DC brush motor. The permanent magnet in the rotor of a BLDCM produces an armature current-independent field. The commutator less BLDCM has laterally stiff rotor which permits higher speed, especially in servo applications. The intra-stator placement of the rotor improves heat conduction which increases electric loading, and yields a higher torque/amp, better effective power factor and higher efficiency. BLDCM-based drives are popular, due to their performance and price improvements. Disadvantages include the need for shaft position sensing and more complex electronic controller. The IM has been the traditional workhorse for fixed and variable speed drive applications. It is rugged, relatively inexpensive and almost maintenance-free. The rotor slip-dependent torque production worsens the performance and decreases the efficiency of the motor. In the fractional and low integral hp range requiring dynamic performance, high efficiency and a wide speed range, the complexity of induction motor drive makes the BLDCM favorable. The gear-less, direct-application SRM drives are widely accepted. Their applicability to aircraft engine starter/generator has been demonstrated.

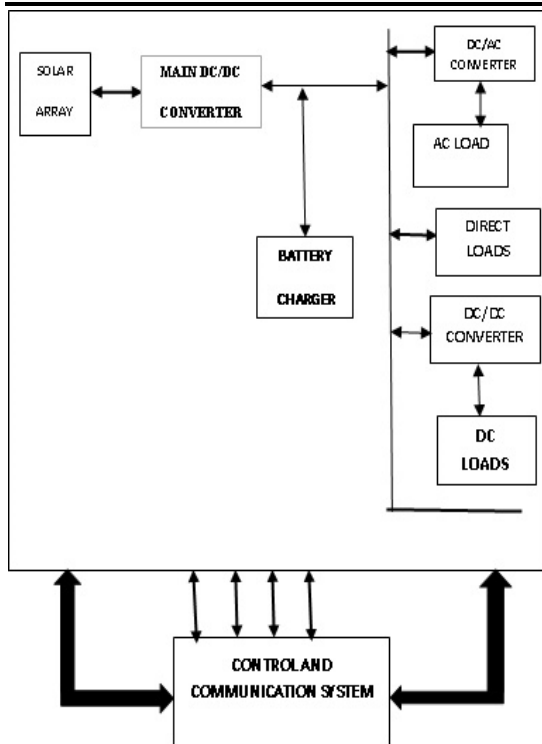

Fig. 2. DC Electric power system.

The motor design and converter topologies of the drive have undergone significant research and development in over two decades. The series connection of the converter phase-leg switches to the motor phase winding prevents shoot-through fault by the converter switches. The motor is economical, compact in construction, and has high torque-to-inertia ratio, high torque output at low-to-moderate speeds, and faster response in servo systems. Its drawbacks are higher torque ripple and acoustic noise, complex control, and the need for an absolute rotor position sensor for the controller to establish the phase current pulses.

### V. AEROSPACE POWER SYSTEM

The advent of MET for aerospace systems has focused attention on AC and hybrid DC and AC-based power management and distribution (PMAD) systems. The schematics in Figs. 4 and 5 show a commonality in the use of electronic converters, photovoltaic (PV) solar arrays and batteries. In aerospace systems, PEBB-related integration issues are the level of power and frequency range, application- and mission-dependent extreme temperature range, weight and size, electromagnetic interference and performance. Resolution of these issues is expected to promote expeditious insertion of electronic modules in aerospace technologies.

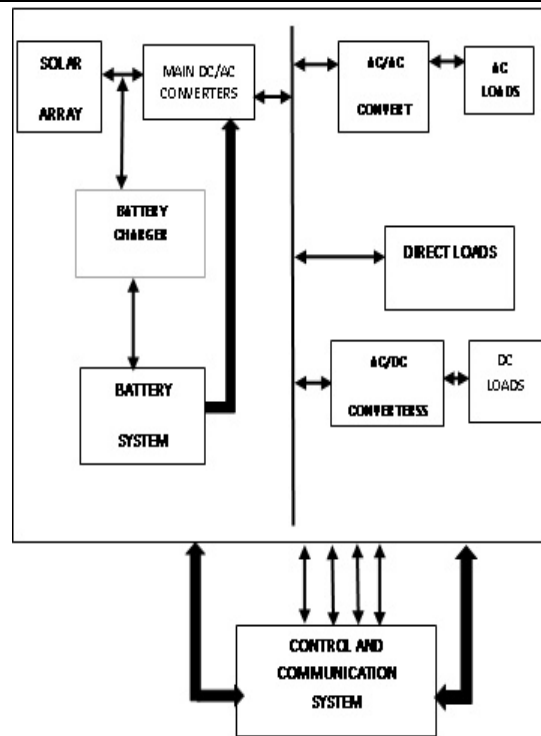

Fig. 3. AC-PMAD-Based Electric Power System.

### VI. POWER ELECTRONICS APPLICATIONS IN AEROSPACE TECHNOLOGIES

The International Space Station (ISS), satellite power systems, MET, starter/generator system, reusable launch vehicles, flywheel technology and onboard electric propulsion are discussed to highlight the important role of power electronics in these systems. A single channel diagram, of the ISS electric power system (EPS) shows a DC network of PV solar arrays, batteries, power converters, switches and user loads. The primary distribution system (PDS) comprises the PV arrays, batteries and the network up to the DC-DC converter units (DDCU's), for 160V to 120V step down to the secondary distribution system (SDS). The sequential shunt unit (SSU) regulates the voltage output of the PV array. The DDCU's isolate the PDS and SDS from each other, and condition the source power for the SDS. The batteries store energy during insolation periods, and supply load power during orbital eclipse.

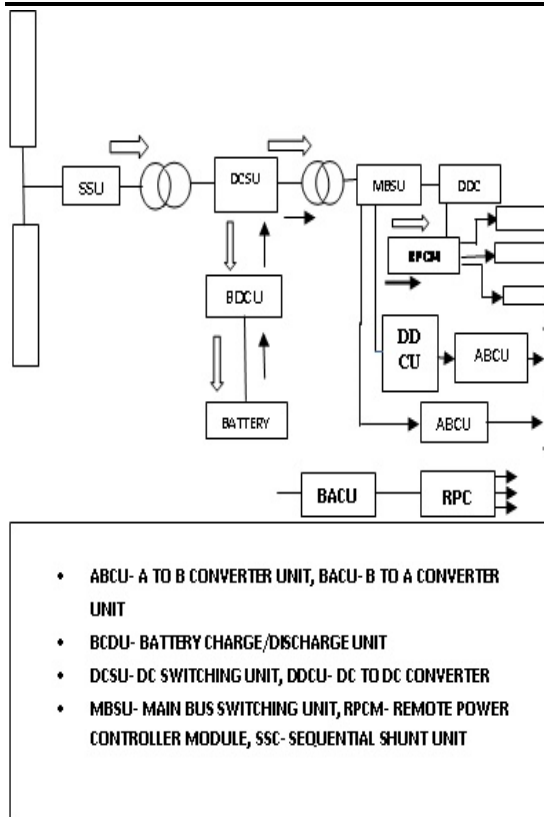

Fig. 4. Single channel diagram of ISS power system.

The battery charge/discharge units (BCDU's) isolate the battery from the primary bus. Remote power controller modules (RPCM's), or switchgears, distribute power to the 8 load converters. The BCDU's, DDCU's and the load converter contain semiconductor switches in their circuitry, thus underscoring the importance of power electronics in the ISS EPS.

## VII. SATELLITE POWER SYSTEMS

A partial block diagram of a satellite modular EPS is shown in Figure 7. It depicts only the north portion of a 'Dual Bus' power system for a geosynchronous satellite [15]. The primary-side elements of the EPS are the PV arrays, battery and power control unit (PCU). On the secondary side, the PCU embodies the SSU, battery charge and discharge converter modules (BCCM, BDCM), and low voltage converter module (LVCM) of redundant, main bus-connected DDCUs which feed the spacecraft loads via the power distribution unit (PDU).

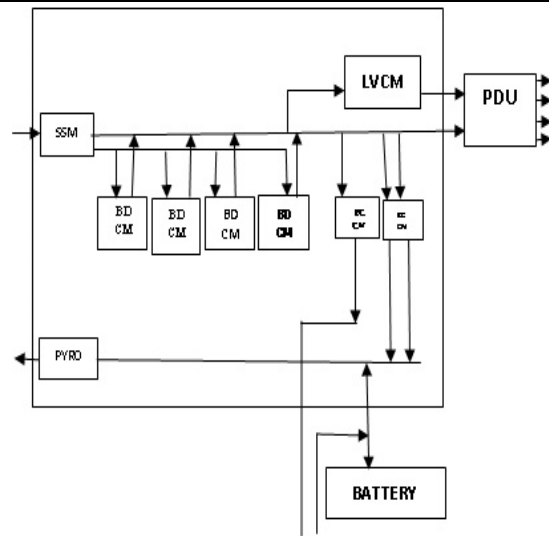

Fig. 5. Block diagram of satellite power system. The operation of the satellite EPS is similar to that of the ISS regarding sunlight and eclipse portions of a mission. The built-in modularity makes it possible to vary battery voltage and output power levels, by adding and removing converter module(s). This feature renders the EPS configurable for future mission. At 0, the modularity facilitates power electronic packaging, equipment deployment into space, and needed on-orbit EPS modifications. The use of power electronics-based motion control systems in selected aerospace systems is discussed next.

## VIII. MOTOR DRIVE APPLICATIONS

The key elements in electric actuation (EA) for MET are the electric motor, its power electronics, the control system and the actuator load(s). Lower costs and advances in power electronics and high speed electric machines have fueled the interest of technologists, developers and researchers in industry, Government Agencies, and academia, in aerospace motion control systems. A key premise of the MET is to replace the traditionally mounted auxiliary drives and bleed air extraction with integral engine starter/generators (S/G's), electrical driven actuators and engine-gearbox-driven fuel pumps. The replacement eliminates hydraulic, pneumatic and mechanical power, and minimizes and/or eliminates their associated costs, as well as high pre-flight operation, maintenance and refurbishment of hydrazine-driven auxiliary power units (APU's).

## IX. STARTER OR GENERATORS

A general variable speed constant frequency (VSCF) system is shown in Fig. The machine may be any of the three candidates. During motoring, constant frequency (CF) electrical power from the main AC bus is converted to VF by the bi-directional power converter, and fed to the machine to start the load such as an aircraft engine. In the generating mode, the variable speed load provides mechanical power to run the machine the variable frequency of which is converted to a constant frequency for the main bus.

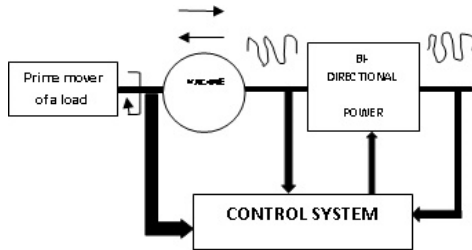

Fig. 6. Block diagram of a Generator.

The control system receives inputs from the VSCF sources, and provides gating signals for the converter to maintain proper interface between VF and CF requirements.

## X. REUSABLE LAUNCH VEHICLES

A reusable launch system (RLS or Reusable launch vehicle (RLV)) is a space launch system intended to allow for recovery of all or part of the system for later reuse. To date, several fully reusable sub-orbital systems and partially reusable orbital systems have been flown. However the design issues are extremely challenging and no fully reusable orbital launch system has yet been demonstrated. A wide variety of system concepts have been proposed and several are represented in those which have actually flown. There are two approaches to single stage to orbit or SSTO. The rocket equation says that an SSTO vehicle needs a high mass ratio. "Mass ratio" is defined as the mass of the fully fueled vehicle divided by the mass of the vehicle when empty (zero fuel weight, ZFW). One way to increase the mass ratio is to reduce the mass of the empty vehicle by using very lightweight structures and high-efficiency engines. This tends to push up maintenance costs as component reliability can be impaired, and makes reuse more expensive to achieve. Another is to reduce the weight of oxidant carried, by burning the fuel in air during

the atmospheric stage of flight. A dual-cycle power plant such as a liquid air cycle engine or the proposed SABRE engine is used. The margins are so small with the SSTO approach that there is uncertainty whether such a vehicle could carry any payload into orbit. Two stages to orbit use two vehicles, joined together at launch. Usually the second-stage orbiter is 5-10 times smaller than the first-stage launcher, although in biamese and triamese configurations both vehicles are the same size. Besides the cost of developing two independent vehicles, the complexity of the interactions between them both as a unit and when separating must also be evaluated. In addition, the first stage needs to be returned to the launch site for it to be reused. This is usually proposed to be done by flying a compromise trajectory that keeps the first stage above or close to the launch site at all times, or by using small air-breathing engines to fly the vehicle back, or by recovering the first stage down range and returning it some other way (often landing in the sea, and returning it by ship). Most techniques involve some performance penalty; these can require the first stage to be several times larger for the same payload, although for recovery from downrange these penalties may be small. The second stage is normally returned after flying one or more orbits and reentering. Another name for this concept would be a combination launch system.

## XI. FLYWHEEL TECHNOLOGY

Flywheel energy storage (FES) works by accelerating a rotor (flywheel) to a very high speed and maintaining the energy in the system as rotational energy. When energy is extracted from the system, the flywheel's rotational speed is reduced as a consequence of the principle of conservation of energy; adding energy to the system correspondingly results in an increase in the speed of the flywheel. Most FES systems use electricity to accelerate and decelerate the flywheel, but devices that directly use mechanical energy are being developed. Advanced FES systems have rotors made of high strength carbon-fiber composites, suspended by magnetic bearings, and spinning at speeds from 20,000 to over 50,000 rpm in a vacuum enclosure. Such flywheels can come up to speed in a matter of minutes – reaching their energy capacity much more quickly than some other forms of storage. Additionally to conditioning

power and enabling bi-directional power and stored energy flow in flywheel systems, motor drives feature in electric upgrade of aircraft pumps.

## XII. SERVO SYSTEM

Using high-density motor drives can eliminate the usual size and weight limitations of drives. However, issues of Variable frequency incompatibility with 400Hz-operated aircraft equipment such as fuel and hydraulic pumps, attendant increase in motor weight to achieve the required torque at high frequencies, and potentially high upgrade cost must be resolved. By comparison with CF power, VF motor controllers can reduce transient inrush current at motor start. Furthermore, a variable speed motor-driven fuel pump can provide only the required amount of fuel. Also, such a fuel pump can improve aircraft performance by reducing engine gearbox weight and enabling direct integration with the aircraft electronic propulsion and flight control. Additionally to their use in aerospace power systems electronic converters play an important function in the on-board electric propulsion of spacecraft.

## XIII. ON-BOARD ELECTRIC PROPULSIONS

Power electronics are constituent parts of the power processing unit (PPU) of spacecraft electric propulsion which is credited with reducing launch vehicle requirements, notably for north-south station keeping of commercial geosynchronous satellites. A PPU comprises one or more electronic converters. It provides electric power for the spacecraft thruster, and commands and telemetry interface to the electric propulsion system, as shown in Figure 7. The converters may be current-controlled and voltage-fed, to rapidly supply constant current to offset thruster voltage variations, typically during a start-up period. Small-sized PPUs with a minimal number of lightweight, highly efficient, soft-switching converters yield increased payload and power.

## XIV. ELECTRIC PROPULSION SYSTEM

Such PPUs can generate high voltage start pulse to ignite as many as four arcjet thrusters for north/south station keeping orbit maneuvers, thus reducing propulsion system mass. Several

challenges must be overcome for continued penetration of power electronics into aerospace systems.

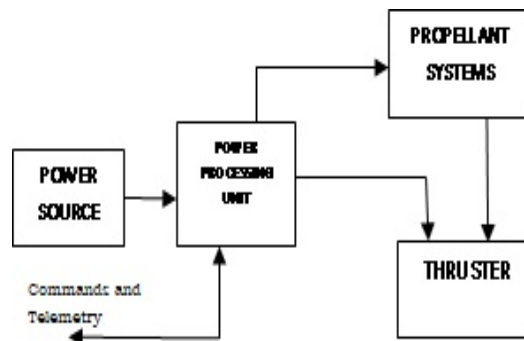

Fig. 7. Block diagram of an electric propulsion system.

## XV. CONCLUSION

This paper mainly concentrates on the role of power electronics devices and applications in Space science and technology. It encloses about the International space station, Satellite power systems, flywheel technology, spacecraft on-board electric propulsion, and reusable launch vehicles.

Power electronics plays a very important and major role in aerospace power systems and on-board electric propulsion. Future multi-voltage needs and varied load requirements demand the use of multi-voltage level converters. The use of electronic modules with dual-use options and hardware commonality for aircraft and spacecraft should reduce development cost and maximize system re-use, while improving system reliability and performance.

## REFERENCES

- [1] NASA Center for Aerospace Information 7121 Standard Drive Hanover, MD 21076.
- [2] National Technical Information Service 5285 Port Royal Road Springfield, VA 22100.
- [3] Available electronically at <http://gltrs.grc.nasa.gov/GLTRS>.
- [4] "Power Electronics Building Blocks (PEBBs)," Project Report by Virginia Power Electronic Center, April 1996.

- [5] Elbuluk, M.E., Kankam, M.D., "Power Electronic Building Blocks (PEBBs) in Aerospace Power Electronics Systems," Paper No. 1999-01-2443, 34th Intersociety Energy Conversion Engineering Conf. (IECEC), Vancouver, BC, Canada, Aug. 1-5, 1999.
- [6] Elbuluk, M.E., Kankam, M.D... "Motor Drive Technologies for the Power-By-Wire (PBW) Program: Options, Trend and Tradeoff, Part II: Power Electronic Converter and Devices," IEEE Aerospace and Electronics Systems Magazine, Dec. 1995.
- [7] Mohan, N., Underland, T.M., Robbins, W.P., "Power Electronics: Converters, Application, and Design," Book, John Wiley & Sons, 1989.
- [8] Ray, W.F., et al., "High Performance Switched Reluctance Brushless Drives," IEEE Trans. on Ind. Electronics, Vol. 22, 0.4, July/Aug. 1986.
- [9] Harris, W.D., Lang, J., "A Simple Motion Estimator for Variable Reluctance Motor," IEEE Trans. on Ind. Application CIA), Vol. 26, No.2, Mar. 1990, pp 237-243.
- [10] MacMinn, S.R., Szczesny, Rzesos, W.J., Jahn, T.M, ': Application of Sensor Integration Technique to Switched Reluctance Motor Drives," IEEE Trans. on IA, Vol. 28, No.6, Nov. /Dec. 1992, pp. 1339-1344.