



DESIGN OF MOUNTING PLATE FOR SECTION-IV OF AN AEROSPACE VEHICLE UNDER YAWING CONDITION

Chunchu Sravanthi¹, Pratibha Dharmavarapu², Pooja Angolkar³

^{1,3}Assistant Professor, ²Associate Professor

Department of Mechanical Engineering, Anurag Group of Institutions, Hyderabad, India

Abstract

Aerospace vehicle is divided into number of sections. One of the Sections, Section-IV contains Avionics Batteries and other Aerospace electronics sub-systems. The Section-IV contains an Interface Mounting plate accommodating thermal batteries for control actuation system (3 Nos), Primary Avionics battery (1 No), Battery Voltage Monitoring Circuit (BVMC) package, Secondary Avionics Battery and Contractor Box.

Thermal Batteries and Primary Avionics Battery are mounted on the plate using clamps and brackets and other electronic units like BVMC, Secondary Avionics Battery & Contractor Box are mounted using fasteners. The modeling of Mounting Plate is done using CAD software, ProEngineer Wildfire 5.0 and Analysis is carried out using Analysis CAE Software, ANSYS 12.0. The results are interpreted with various loads and matched with theoretical calculations. The Factor of Safety of Mounting Plate is found within the limits and hence the overall design is found to be safe for Aerospace application.

Keywords: Aerospace, Battery, Mounting Plate, Analysis

I. INTRODUCTION (HEADING 1)

A. Aerospace Vehicle

An aerospace vehicle is designed to move in a defined trajectory by means of guidance of control electronic components. These components have to be mounted inside the aerospace vehicle airframe as per the system configuration. These have to be mounted to

withstand aerospace loads both static and dynamic.

In general, flight vehicle can be a air craft or rocket. Mass properties are vital for the flight vehicle to travel in desired trajectory. The mass properties of the flight vehicle are Weight, Center of gravity and Moment of Inertia. Weight is the force generated by the gravitational attraction of the earth on the model rocket. The mass (and weight) is actually distributed throughout the vehicle and for some problems it is important to know the distribution. But for vehicle trajectory and stability, we only need to be concerned with the total weight and the location of the center of gravity. The center of gravity is the average location of the mass of the vehicle.

B. Yaw Motion

In flight, any aircraft will rotate about its center of gravity, a point which is the average location of the mass of the aircraft. We can define a three dimensional coordinate system through the center of gravity with each axis of this coordinate system perpendicular to the other two axes. We can then define the orientation of the aircraft by the amount of rotation of the parts of the aircraft along these principal axes. The yaw axis is perpendicular to the wings and lies in the plane of the aircraft centerline. A yaw motion is a side to side movement of the nose of the aircraft.

The yawing motion is being caused by the deflection of the rudder of this aircraft. The rudder is a hinged section at the rear of the vertical stabilizer. As described on the shape effects slide, changing the angle of deflection at the rear of an airfoil changes the amount of lift generated by the foil. For the vertical stabilizer

and rudder, the orientation of the airfoil causes a side force to be generated. With greater deflection of the rudder to the left, the side force increases to the right. With greater deflection to the right, the side force increases to the left.

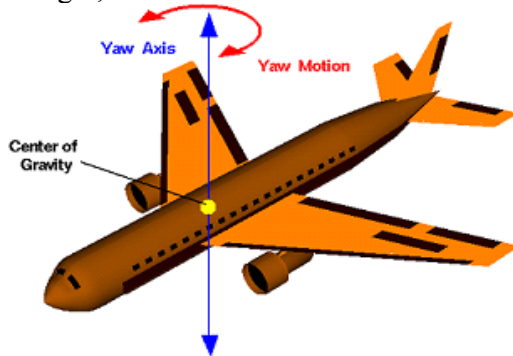

Fig 1 Flight Vehicle- Yaw Motion

II. MODELLING

The Section-IV of Aerospace vehicle houses sub systems meant for Control Actuation. These sub systems are mounted on mounting plate which has to be assembled inside the section (airframe) of given dimensions using four brackets. The mounting Plate carries Subsystems like

- Thermal Batteries for Control Actuation System (3 No's)
- Primary Avionics Battery
- BVMC-Battery Voltage Monitoring Circuit
- Secondary Avionics Battery
- Contactor Box.

The total mass of the Assembly resting over the four Brackets is around 17.7 Kg. The entire configuration described above is shown in Figure 2

The weight of the Sub system under the longitudinal acceleration levels of 27.5g and lateral acceleration levels of 8g imparts external loading in the form of forces and moments over the mounting plate. The mounting plate is designed and analysed to withstand the acceleration loads.

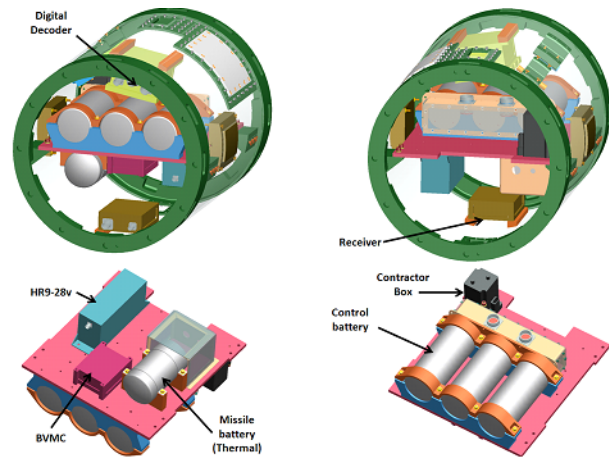

FIG2: SECTION4 AIR FRAME WITH PACKAGES MOUNTED ON PLATE

III. DETAILS OF INDIVIDUAL PACKAGES

A. Mounting Plate

The mounting plate with sub systems are modelled in ProEngineer CAD software.

Aluminium Alloy 24345 (WP condition) material is used for Plate and its properties are given below.

Plate (IS: 736) : UTS: 405 MPa, PS: 310 MPa, %e: 7



FIG:3 Mounting plate

B. Control Battery (Thermal) with Clamps and Brackets

Control Battery (Thermal) is used for supplying power to the control actuation system. The Control Batteries (Thermal) are of Ø80x190 length. Three number of batteries are mounted in series on bottom mounting brackets and clamped using M5 screws (8 No's) using top clamps. Bakelite Hylam Grade F2 IS:2036

material has been used for mounting the batteries for insulation.

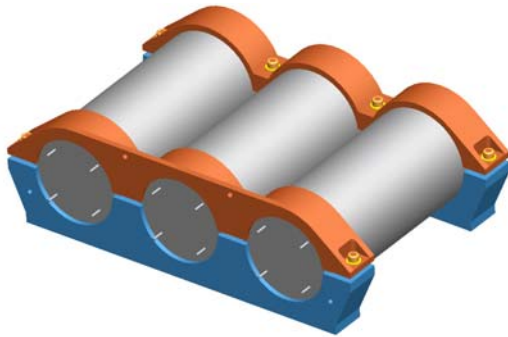

FIG:4 Control Battery with Clamps and Brackets

C. Avionics Battery (Thermal) mounted on clamps and Brackets

Avionics Battery (Thermal) is used for supplying power to the electronic packages mounted in Sections II to IV. The Battery is of Ø80x145 length. The battery is mounted on mounting brackets and clamped using M5 screws (8 No's) using top clamps. Bakelite Hylam Grade F2 IS:2036 material has been for mounting the batteries for insulation.

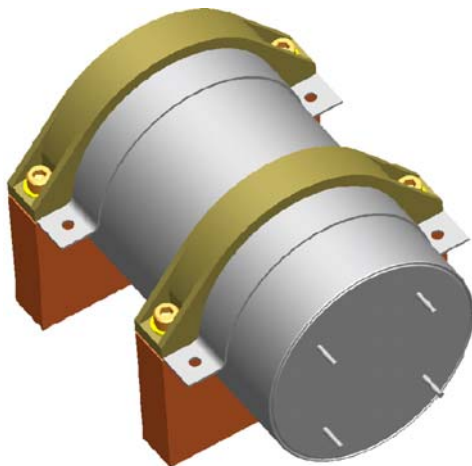

FIG:5 3D Modelling of Avionics Battery Mounted on Clamps and Brackets

D. BVMC (Battery Voltage Monitoring Circuit) Package

Battery Voltage Monitoring Circuit Package is used for monitoring of voltages of various Batteries mounted in Section-IV. The Output Voltages of all batteries are monitored and converted into Digital form and send to On-board Computer for Telemetry Applications.



FIG:6 Model of Battery Voltage Monitoring Circuit Package

E. HR-5 9V Battery

HR5-9V Battery is used for powering-up the Autonomous Aero-space Vehicle Destruction System (AVDS). The Battery provides 5 Amps at 9V Volts to the necessary External AVDS.

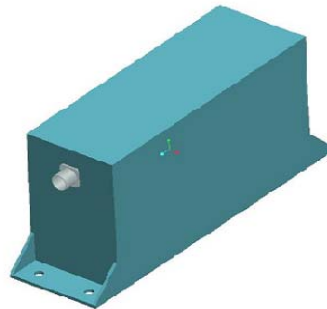

FIG: 7 Model of HR5-9V

F. Contractor Box

The Contractor Box is used for activating the Control batteries for Actuating Purpose. The Control Batteries (3 Nos) are connected in series to provide a actuating voltage of 150 V. The Contractor Box receives command from On-board Computers to enable the Actuating Voltage to Actuating Systems.



FIG:8 Model of Contractor Box

IV. ANALYSIS

The Plate would be subjected to the external loads and moments due to loading caused by the packages mounted on the plate during yawing condition. Analysis is carried out in pitching

condition and the results are depicted and tabulated.

The mounting plate having sub system mounting holes with brackets is imported to ANSYS software. The Plate is modelled using eight noded Shell elements (Shell 281) with a uniform thickness of 8 mm. Lugs are modeled using a SOLID 20 noded Tetrahedral element (SOLID 187). A total of 87471 elements are used for this assembly with 4983 elements for the Plate and 82488 elements for the Lugs. The nodes of holes at the lugs to be interfaced with Airframe are arrested in all degrees of freedom and the nodes of holes interfacing Plate and lugs are coupled together in all degrees of freedom.

A. Loading In Lateral Direction (Yaw)

In Yaw condition, Direct load is applied on the plate by the respective packages mounted locations in both yaw left and right condition. Boundary conditions and the Forces applied over the plate is shown in Figure 6.1. The Stresses and deflections induced in the Plate and Brackets are shown in Figure 10 to Figure 13

Weight of Thermal Battery (Control) with brackets= 8.98 Kg

Force caused by Battery in 8 g state = 8.98 * 9.81* 8= 704.75 N

Load transfer to plate at each mounting hole = 704.75 / 8= 88.1 N

Weight of Thermal Battery (Avionics) with brackets= 2.26Kg

Force caused by Battery in 8 g state = 2.26 * 9.81* 8= 177.4 N

Load transfer to plate at each mounting hole = 177.4 / 4= 44.4N

Weight of Battery (HR5-9v) = 1.95 Kg

Force caused by Battery in 8 g state = 1.92 * 9.81* 8= 150.7 N

Load transfer to plate at each mounting hole = 150.7 / 4= 37.7N

Weight of BVMC package = 0.7 Kg

Force caused by Battery in 8 g state = 0.7* 9.81* 8= 55 N

Load transfer to plate at each mounting hole = 55 / 4= 13.75 N

Weight of Contactor package = 0.76 Kg

Force caused by Battery in 8 g state = 0.76 * 9.81* 8= 59.6 N

Load transfer to plate at each mounting hole = 59.6 / 2 = 29.8 N

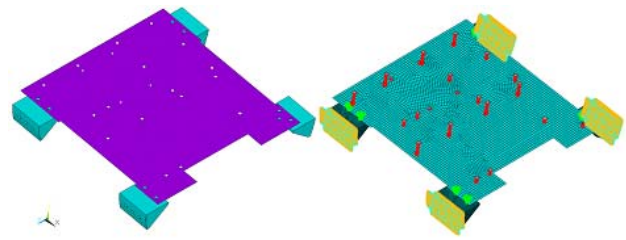
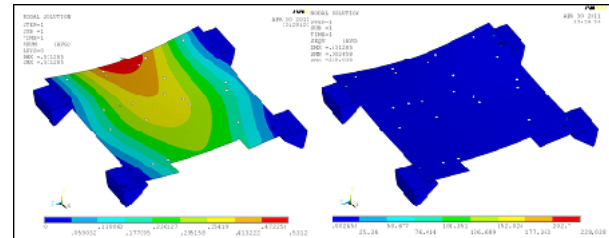

Fig 9: FE model and boundary condition plot



Deflection & stress plot with plate and brackets

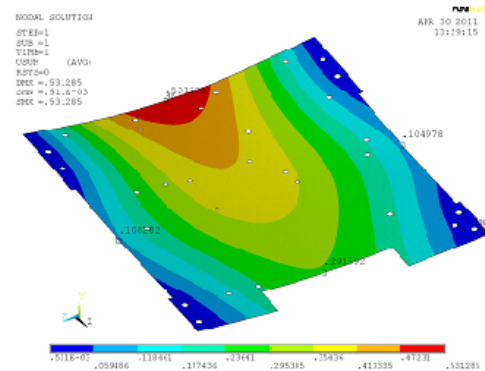

Fig 10 : deflection of plate under Yawing

From the Fig 10, The maximum deflection obtained for Plate is 0.53 mm.

V. ANALYSIS

Assuming the loading on the plate to be a Rectangular plate with edges built in condition with load at the center (Theory of Plate & Shells-S. Timoshenko, Woinowsky-Krieger, Page No. 206, Table 37), the load of all the packages including plate is 17 Kg.

Length of the plate b = 400 mm, Width of the plate a = 345 mm, b/a = 1.2,

$$\text{Deflection of plate} = \alpha \frac{P a^2}{D}$$

Where $\alpha = 0.00647$, (based on b/a ratio)

P = Load on the plate = 17 Kg = 17*9.81*8= 1334.16 N

a = 345 mm

$$D = \frac{E h^3}{12(1-\mu^2)} = 3282051.3$$

Where $E = 0.7e5$, $h =$ Thickness of the plate = 8 mm,

$$\mu = 0.3 \text{ mm}$$

substituting the above values, Deflection of plate = 0.3 mm

The calculated deflection is less compared to FE result. This is due to the plate being fixed rigidly on the four edges. The calculation is used for a qualitative assessment.

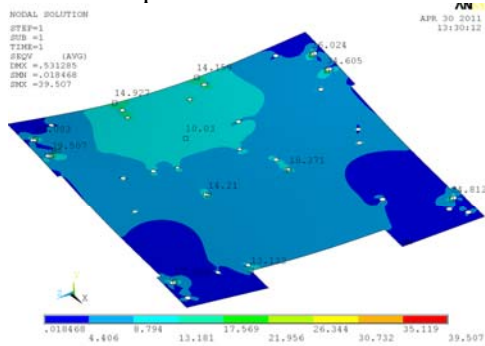

FIG:11 Induced Stresses in Plate Yawing

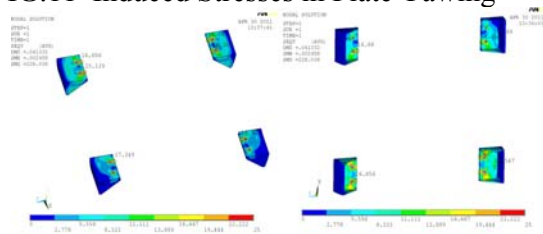

FIG: 12 Induced Stresses on Brackets under Yawing

From Figure 11, Maximum induced Stress in the Plate = 39.51 MPa

$$FOS = 310/39.51 = 8$$

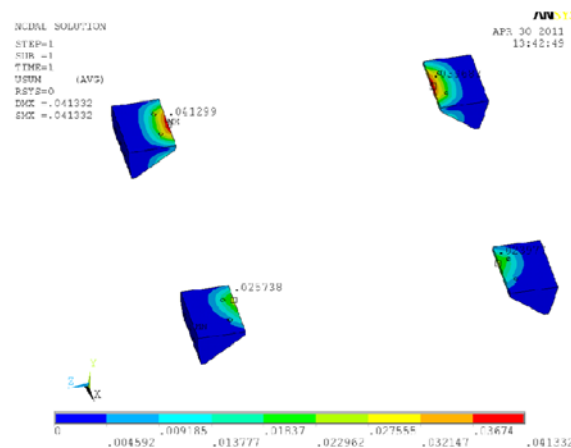

FIG: 13 Deflection in brackets under Yawing

VI. CONCLUSIONS

The permissible Factor of Safety for design of Aerospace vehicles structures is 1.5

Maximum deflection obtained for Mounting Plate under pitching condition is 0.055mm which is within the limits.

- Maximum Stress obtained for Mounting Plate under pitching condition is 66MPa which gives FOS equal to 4.7 which is greater than 1.5. Hence the design of Mounting Plate is safe.

8. Acknowledgement

We are thankful to Mr. Umakanth, Senior Scientist of Research Centre Imarat, DRDO, Hyderabad for his valuable inputs for completing the tasks at our institute. We are also sincerely thankful to the Management of Anurag Group of Institutions for allowing us to do the project.

VII. REFERENCES

- [1] MIL-HDBK-5B, Metallik Material and Elements for Aerospace Vehicle Structures, Department of Defence (DoD), Washington DC.
- [2] Theory of Plate & Shells-THIMOSHENKO
- [3] Finite Element Analysis by CS KrishnaMurhty
- [4] Introduction to Finite Elements in Engineering Practice by “ Tirupati R. Chandrapatta and Ashok D. Belugundu”
- [5] Theory of Machines by SS Rattan.
- [6] Strength of Materials-B.C. Punmia
- [7] <http://www.ijettjournal.org/volume-8/number-7/IJETT-V8P267.pdf>
- [8] https://books.google.co.in/books?hl=en&lr=&id=hMejr4alehQC&oi=fnd&pg=PP7&dq=design+and+analysis+of+composite+structures+with+applications+to+aerospace+structures&ots=iG2TSc2n10&sig=SzeGHXu_jsVdFKn3H27aKIPOaHI