



STANDALONE MARITIME BOUNDARY PROTECTION SYSTEM USING FLOATING STATION

Tamilselvan.P¹, Manimaran.V², Vinoth.S³, Dr Senthil Kumar.K.K⁴
^{1,2,3}UG Student, ⁴Head of the department, ECE,

^{1,2,3,4}Prince Shri Venkateshwara Padmavathy Engineering College, Tamil Nadu, India.

Abstract

This Project tells about the prevention of fisherman from going outside the border by placing a floating module in the respective sea border. The floating module consists of hybrid power generation section and receiver section. When the fisherman is near to the border, he will be alerted by the coast guard. In the conventional, the fishermen have to keep watch the maritime border, which cannot be easily separated as land region. If they crossed certain limit on the sea, they have to pay penalty or get arrested by the naval guards of the neighbour country. This system can be proved to be efficient in not only protecting our fishermen but can also aid us in maintaining a check on unauthorized poaching. Reduction in conflicts will improve the bilateral relation between the countries. This system requires minimum human interference for communication thus it can be quick and reliable. The project generates alarm if they cross the border by mistake. with the simple circuitry and the use of Received Signal Strength Indicator(RSSI) makes the project a low cost product, which can be purchased even by a poor fisherman. It is very quick and reliable. Thus our system will save the lives of fishermen and provide good relationship with the neighbouring countries.

Index Terms: PIC. Transmitting Base Station, RF Signal, Message, Receiver .

I. INTRODUCTION

This Project tells about the prevention of fisherman from going outside the border by

placing a floating module in the respective sea border. The floating module consists of hybrid power generation section and receiver section. The hybrid Section uses both solar and wind sources for power generation. It is given to the PIC Controller.

II. HARDWARE DESCRIPTION

This System uses the Hybrid module for power generation by solar and wind sources. This is connected to the pic controller .This will display the amount of power generated in solar and wind turbine. The Receiver is connected to the pic controller. The transmitter is placed in the boat. It has transmitter module and transmitting antenna. The receiver receives the signal from transmitting antenna, decodes it and given to the PIC controller.

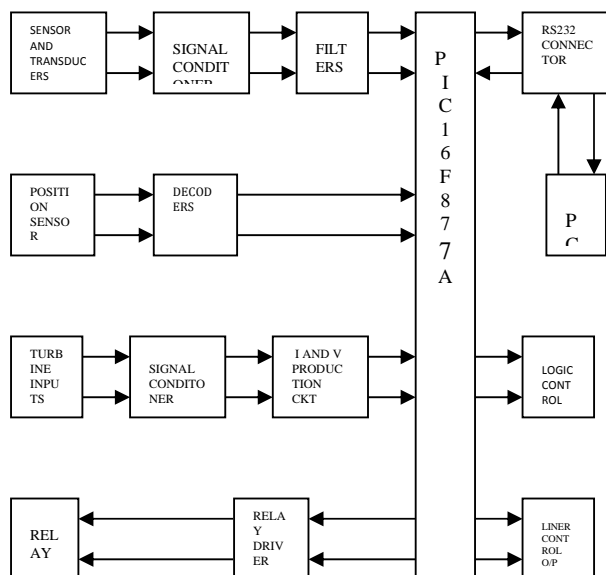

Fig 1: Overall Block Diagram of embedded system

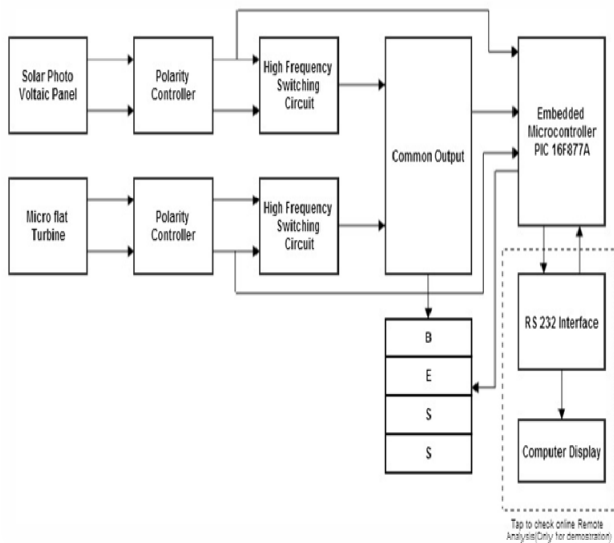

Fig 2:Block Diagram Hybrid model

A.SOLAR PANEL

Solar cell is a p-n junction diode of large area (1-100 cm²), which converts energy of the incident photons into electrical energy. A typical construction of a p-n junction solar cell, which consists of a shallow p-n junction formed on the surface of a substrate, front ohmic contact grids and a back ohmic contact, and an antireflection coating on the front surface.

The solar panel operation, When a solar cell is exposed to solar spectrum, photons having energy equal to or greater than the band gap (E_g) of the solar cell material, get absorbed and hole and electron pairs are generated, which are collected by the respective terminals. Figure 3.10 shows the solar panel operation. Photon energy in excess of ' E_g ' is converted into electrical energy while photon energy less than ' E_g ' is either dissipated as heat in the solar cell or transmitted through. The current source ' I_{ph} ' results from the charge carriers excited by solar radiation.

B.WindTurbine

Wind mills that produce electricity are very eco-friendly. For one thing, they produce no harmful waste products. Also, they do not require consumption of a limited amount of natural resources nor do they endanger the environment through mining or drilling. The natural resource, wind, is already available and cannot be used up. As the concern about fossil fuels and the impact it has had on our

environment grows, there are more efforts being diverted to finding renewable energy sources. You have to have a wind supply in order for them to work.

If there is no wind, the blades will not spin and nothing will be produced. Windmills are not very practical in areas of the world where there is little to no wind. However, as long as you live in a region that experiences plenty of wind, you will find that windmills are a cheap source of energy and can create electricity without the harmful effects. Here turbine used is rotated at 60rpm and produces the output of 230v. This output is given to the Step down transformer. It will produce 12v output. Then it is given to the Power supply unit.

C. POLARITY CONTROLLER

A diode is a specialized electronic component with two electrodes called the anode and the cathode. Most diodes are made with semiconductor materials such as silicon, germanium, or selenium. Diodes can be used as rectifiers, signal limiters, voltage regulators, switches, signal modulators, signal mixers, signal demodulators, and oscillators. The fundamental property of a diode is its tendency to conduct electric current in only one direction.

When the cathode is negatively charged relative to the anode at a voltage greater than a certain minimum called forward break over, then current flows through the diode. If the cathode is positive with respect to the anode, is at the same voltage as the anode, or is negative by an amount less than the forward break over voltage, then the diode does not conduct current. This is a simplistic view, but is true for diodes operating as rectifiers, switches, and limiters. The forward break over voltage is approximately six tenths of a volt (0.6 V) for silicon devices, 0.3V for germanium devices, and 1V for selenium devices.

D. High Frequency Switching Circuit

The technique used by the high Frequency circuit is the pulse charging technique. This is Trickle method in boost charging system. A high end high frequency charging technique will be employed to charge the battery without loading the turbine and photo-voltaic cell. This method reduces the charging time. For example if cell phones are charged using this way, then the cell phones will not get heated up. The switching circuit consists of the 555timerandaMOSFET.The 555 timer works as

the stable multi vibrator which produces pulses of required frequency

E.PIC

The PIC Microcontrollers are supported with a full range of hardware and software development tools. The used PIC16774 device comes in 40 pin package To communicate with the PIC we are using RS232 port of the computer. So we have to initialize the port before using it. To initialize and to communicate with the PIC, the file COM.C defines and uses several functions.

To perform the various operations and conversions required to switch, control and monitor the devices a processor is needed. The processor may be a microprocessor, micro controller or embedded controller. In this project an embedded controller has been preferred because of its industrial advantages in power electronics like built in ADC, RAM, ROM, ports, USART, DAC. This leads to lesser space occupation by the circuit and also the speed of embedded controllers are more compared to other processors. The embedded controller selected for this project is PIC16F877A due to its various features.

III .PROPOSED SYSTEM

- Usage of Tidal Energy instead of Wind Energy:

The goal of this phase is to generate power of the Floating Station using Tidal Energy instead of Wind.

- Providing solution to identify the boat: The goal of this phase is to provide UIC (Unique Identification Code) for identification of Boat.
- Transmission of Data: The goal of this phase is that we can transmit the information about Fisherman and Boat.

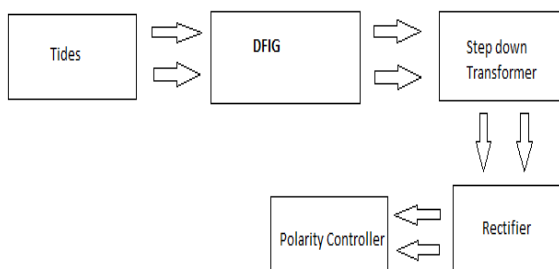

Fig 3:Tidal Energy Generation Phase

Providing Solution to identify the Boat

- The seashore guards will provide a Unique Identification Code to Boat. This number is generated randomly. After returning to the sea shore this number will be deleted. Thus using this number we can identify whether the boat has returned or not.In this phase a Unique Identification Code(UIC) will be given to the fisherman who was moving to the sea. After returning to the shore the fisherman will return back this UIC to the seashore guard and it cancelled automatically. It is like mobile number which will be randomly generated. Thus with this number we can verify whether the boats went for fishing is returned safely or not.

Transmission of Data:

- At the boat the fisherman will be provided with a transmitter of four buttons. Each button indicates for each of the purposes. Each button will used to give alert during the emergency situations such as
 - Hidden Code,
 - Low Fuel Availability,
 - Health Hazard,
 - Any problem to boat respectively.

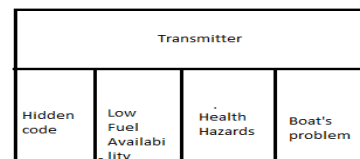

Fig 4:Transmitter placed at the boat

The transmitter placed at the boat and In this Phase the fisherman will be provided with a Transmitter which consists of four switches . On pressing the switch, the message will be transmitted to the Floating Station. By using this emergency message will be transmitted to Coastal Guard and thus they will safeguard them. Thus if any crucial situation occurs then this Transmitter will be used. The antenna will be fixed in both the sender and the receiver for the transmission of data between them.

Advantages of Proposed System

- Overcomes the drawbacks of the Wind energy i.e. the wind energy sometimes will not be available.
- We can identify that whether the boat has been returned to shore or not by using the UIC.
- In case of any danger it will be identified by the Coastal Guards and they will help us.
- Since we are using IOT the message is easily transmitted to the Guards to help us.
- The distance will be calculated by using the Humidity that have been calculated + the RSSI (Reduced Signal Strength Indicator).

give alert during the emergency situations situations such as

- Hidden Code,
- Low Fuel Availability,
- Health Hazard,
- Engine Failure .

In this Phase the fisherman will be provided with a Transmitter which consists of four switches. On pressing the switch, the message will be transmitted to the Floating Station. By using this emergency message will be transmitted to Coastal Guard and thus they will safeguard them. Thus if any crucial situation occurs then this Transmitter will be used. The antenna will be fixed in both the sender and the receiver for the transmission of data between them

IV. System Requirement

A. Hardware Requirements

- System : Pentium IV 2.4 GHz.
- Hard Disk : 40 GB.
- Floppy Drive : 1.44 Mb.
- Monitor : 15 VGA Colour.
- Ram : 1 Gb.
-

B. Software Requirements

- Operating system : Windows XP above with 64 bit.
- Front End : VISUAL BASIC
- Back End : Embedded C

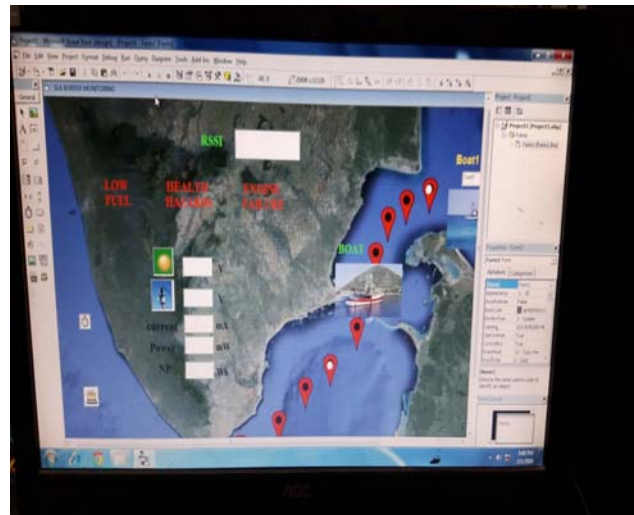

Fig 5: Output

V. RESULT ANALYSIS AND DISCUSSIONS

The output the seashore guards will provide a Unique Identification Code to Boat. This number is generated randomly. After returning to the sea shore this number will be deleted. Thus using this number we can identify whether the boat has returned or not. In this phase a Unique Identification Code(UIC) will be given to the fisherman who was moving to the sea. After returning to the shore the fisherman will return back this UIC to the seashore guard and it cancelled automatically. It is like mobile number which will be randomly generated. Thus with this number we can verify whether the boats went for fishing is returned safely or not. At the boat the fisherman will be provided with a transmitter of four buttons. Each button indicates for each of the purposes. Each button will used to

A. KIT MODEL

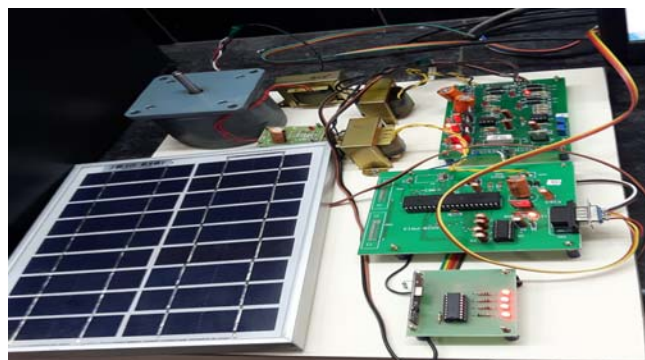

Fig 6: Hardware configuration

Hardware configuration of the life-saving project. By keeping the Unique Identification Code in the boats, if the boat cross the border we can use our kit to assist the track.

The lost ship wrecks due to natural calamities can be identified. The project has been developed at a low-cost product so it can be purchased even by a poor fishermen.

VI. CONCLUSION

The conclusion of the project by keeping the Unique Identification Code in the boats, if the boat cross the border we can use our kit to assist the track. The lost ship wrecks due to natural calamities can be identified. The project has been developed at a low-cost product so it can be purchased even by a poor fishermen.

This System has been developed in such a way that it saves the lives of the many fishermen by alerting them not to navigate beyond the country border. The system is used to detect the maritime boundary of the country

VII. REFERENCES

- [1] Chenn, Q. (2005) 'Programming of PIC Microcontroller for Power Factor Correction', International Journal of Students Research in Technology and Management, Vol.25, No.11, pp.124-325.
- [2] Domenico Caputo, M. and Corrado Fanelli, K. (2012) 'Border crossing detection and tracking through localized image processing', International Journal of Innovative Research in Wireless Radar Sensor networks, Vol.18, No.6, pp.2674-2677.
- [3] Irwandi, S. (2013) 'GPS Based Vessel Position Monitoring And Display System ', IEEE Aerospace and Electronic Systems Magazine, Vol.11, No.13, pp.978-981.
- [4] Jolliffe, I.T. (2005) ' RF based Fishing Vessel Surveillance System', IEEE Aerospace and Electronic Systems Magazine , Vol.15, No.9, pp.295-395.
- [5] Michalski, A. and Czajewski, J. (2011) 'The accuracy of the Global Positioning Systems', IEEE Instrumentation and Measurement Magazine, Vol.7(1), No.10, pp.56-60.
- [6] Treutter, D. (2014) ' Border Alert System for Boats using ZigBee', International Journal of Innovative Research in Computer and Communication engineering, Vol.33, No.19, pp.1295-1395.
- [7] Yoshioka, N. (2008) 'Integrated Controls at Border Crossing', IOSR Journal of computer engineering, Vol.18, No.17, pp.395-445.

- [8] Zhou Yanming and Xin Xue Hao Xiaoli , (2014) ' Border alert system for fishermen using GPS', International Journal of Students Research in Technology and Management, Vol.02, No.8, pp.3981-3985