



INTERNET OF THINGS (IOT) BASED POWER FLUCTUATION MONITORING SYSTEM

Dr .C. Vimalarani¹, V. Devipriya², M. Banu Priya³

Department of Electrical and Electronics Engineering, K.L.N. College of Engineering
Pottapalayam, Sivagangai

Abstract

A power quality monitoring system based on Arduino uno is proposed in this paper. The monitoring system uses the high accuracy precision rectifier unit and Arduino uno. The monitoring system can monitor voltage and current fluctuations. This method provides the communication between the Electricity Board (EB) server and consumer sector using Internet of things (IOT). It transmits the customer's electricity consumption and bill information is calculated using Arduino uno. Load demand monitoring is done whenever there is a exceed level in set value of power consumption, that can be identified and notification can be sent from the Electricity Board server to the customer and key (it has on/off control) is used to cut off the auxillary load to the customer from Electricity board server.

I. INTRODUCTION

Internet of things has helped many organizational systems to improve efficiency, increase the speed of processes, minimize error and prevent theft by coding and tracking the objects. Computing and communications has its future in the technological transformation brought by the IOT. Power consumption can be reduced to a great extent, if we can monitor our daily power usage and switch off appliances which are unnecessary consuming electricity. This paper focuses on developing a monitoring system using the concept of Internet of Things. There are many blemishes and mistakes in customary charging. Some human errors may likewise happen in manual charging [5].

The Vitality Observing Framework is proper for Ventures, producing plants, business structures or any circumstance where an electrical framework is utilized [1]. The power fluctuations are checked for utilizing the

voltage and current are sustained to the microcontroller which shows it to the electric Board. Contingent upon the power age, the house hold gadgets are controlled consequently. From Power Board area the data in regards to the bill sum and installment are imparted to the purchaser by means of Worldwide Framework for Portable correspondence [2]. A voltage fluctuation and monitoring system in view of virtual instrument was created, where the wavelet change was connected to virtual instrument by utilizing the MATLAB content hub in LabVIEW. The assessment lists of here and now flash seriousness were gotten by utilizing measurement arranging calculations[3]. A power quality monitoring system based on MSP430 The checking framework employments the high precision electronic vitality estimation coordinated circuit ATT7022E and low power utilization microcontroller.

The checking framework can screen voltage, current; the correspondence work understood the information transmission by General Bundle Radio Administration. It is demonstrated that the observing framework isn't just an exact allot of electrical vitality, however likewise to precisely distinguish the variation from the norm and record it[4, 5]. The approach for observing the control quality (PQ) by execute the observing framework that ready to identify the power variance progressively. The observing framework obtained the power motions by utilizing power estimation IC which perform count of energy quality files which interfaced by utilizing ARM7 microcontroller [6, 7]. In this paper, power fluctuation monitoring system for LT consumers are based on Arduino uno is designed. The paper is

described into two part Hardware design and Software design.

II. HARDWARE DESIGN

HARDWARE ARCHITECTURE:

In the proposed system, the hardware consists of potential transformer (PT), current transformer (CT), precision rectifier unit, Arduino Uno, LCD, driver circuit, IOT module, set value, keys. The simplified system architecture is shown in figure-1.

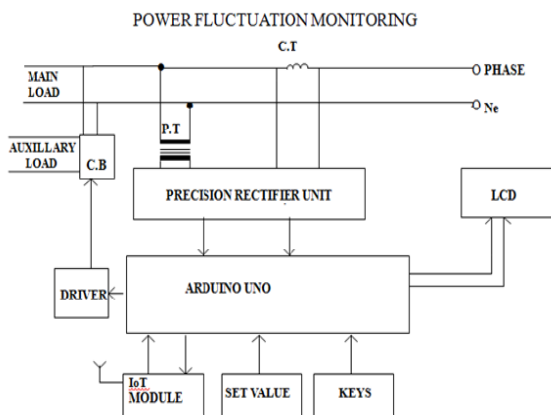

Fig.1 Block diagram of power fluctuation monitoring for LT consumers using IOT

A. ARDUINO:

Arduino is an open-source stage utilized for building gadgets ventures. Arduino comprises of both a physical programmable circuit board (regularly referred to as a microcontroller) and a bit of programming, or IDE (Integrated Development Environment) that keeps running on our PC, used to compose and transfer PC code to the physical board. The Arduino stage has turned out to be very well known with individuals simply beginning with gadgets, and all things considered. Dissimilar to most past programmable circuit sheets, the Arduino does not require a different bit of equipment keeping in mind the end goal to stack new code onto the board - you can basically utilize a USB link. Moreover, the Arduino IDE utilizes a disentangled rendition of C++, making it less demanding to figure out how to program. At long last, Arduino gives a standard shape factor that breaks out the elements of the smaller scale controller into a more open bundle. The Uno is one of the more prevalent sheets in the Arduino family and an awesome decision for apprentices.

B. LCD DISPLAY:

LCD is mostly utilized for show the data. Here we are utilizing 2x16 LCD. Operation of the LCD is the declining costs of LCDs. The capacity has to show the numbers, characters, and designs. This is as opposed to LEDs, which are restricted to numbers and characters. The LCDs are light weight with just a couple of millimeters thickness. Since the LCDs devour less power, they are good with low power electronic circuits, and can be controlled for long spans. The LCDs have long life and a wide working temperature go.

C. IOT MODULE (PROPOSED SYSTEM):

Since IOT is costly when compared to SMS, monitoring of energy meters at lower cost is made possible. Daily consumption reports are generated which can be monitored through Android app. Also, android users can pay their electric bills from their android app. Non-android users can monitor and pay their bills online. The system is more reliable and accurate reading values are collected from energy meters. Live readings of the energy meter can be viewed through Android application. Also, the readings can be viewed online. The human intensive work is avoided and all the values are maintained in the central server. The communication medium is secure and tampering of energy meters can be identified easily. If an error occurs in the system, the value in the central server will not be updated. Once the value updated crosses the threshold time, the server can determine that something is wrong in the system and can report the engineers in EB. Thus, identification of error becomes easier. Since the values are stored in the central database, the reports are made accessible from anywhere in the world. Also, the server is online 24x 7.

D. POTENTIAL TRANSFORMER:

Voltage measurement circuit is used to sense the voltage in between the phase and neutral of a power system. Here 230V supply given to the primary winding of the potential transformer. The potential transformer will step-down the voltage into (6V-0-6V). This transformer is connected to the rectifier and filter circuit. This circuit will convert the AC voltage into DC voltage.

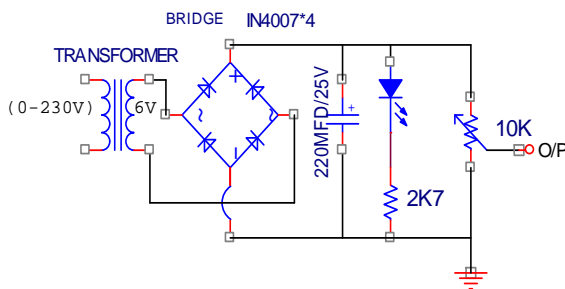

Fig. 2 Voltage Measurement Circuit

E. CURRENT TRANSFORMER:

Current is measured with the help of a current transformer. The current transformer will convert the load current into lower values that current output will be converted in to voltage with the help of the shunt resistor. Then the corresponding the AC voltage will be rectified with the help of a precision rectifier. Then the rectified output will be given to the next section. This output is fed to the micro controller.

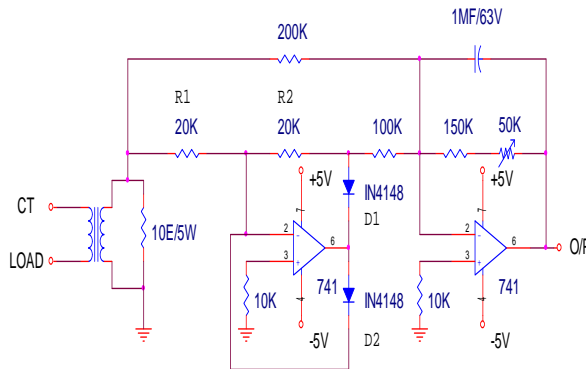

Fig. 3 Current Measurement Circuit

F. CIRCUIT BREAKER:

A circuit breaker is a consequently worked electrical change intended to shield an electrical circuit from harm caused by abundance current, regularly coming about because of an overburden or short out. Its essential capacity is to interfere with current stream after blame is distinguished. Not at all like a wire, which works once and after that must be supplanted an electrical switch can be reset (either physically or naturally) to continue ordinary operation. Circuit breakers are made in differing sizes, from little gadgets that ensure low-current circuits or individual family unit apparatus, up to expansive switchgear intended

to secure high voltage circuits sustaining a whole city.

G. PRECISION RECTIFIER UNIT:

The signal processing applications with low voltage, current and power levels require rectifier circuits. The normal diodes can't correct voltages beneath the cut-in-voltage of the diode. A circuit which can go about as a ideal diode or precision rectifier –handling rectifier circuit for amending voltages which are beneath the level of cut-in voltage of the diode can be composed by setting the diode in the input circle of an op-amp. Figure (4) demonstrates the game plan of an exactness diode, capacities as a non-modifying exactness half-

Wave rectifier Circuit.

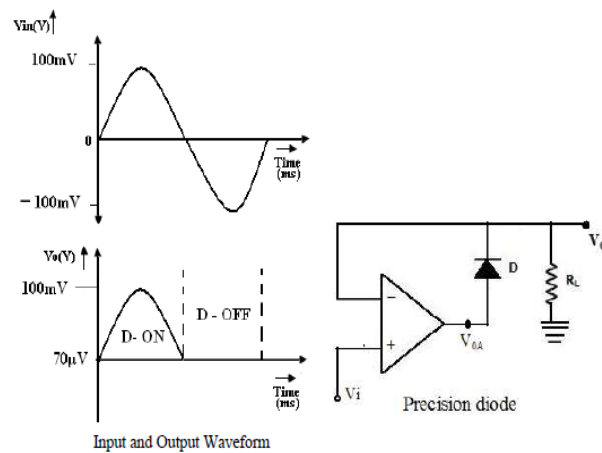

Fig. 4 Precision Rectifier Unit

H. DRIVER CIRCUIT:

They are typically used to manage current moving through a circuit or to control different factors, for example, different parts, a few gadgets in the circuit. The term is frequently utilized, for instance, for a particular coordinated circuit that controls high-control switches in exchanged mode control converters.

I. SET VALUE:

Set value is a user selectable analog value. If any abnormal power fluctuation occurs, it can be controlled by the Electrical board by shutdown the load with the help of keys.

F. KEYS:

It is used for acknowledgement details whether to start or stop the auxillary load.

III. SOFTWARE DESIGN:

This Flow chart Represent software operation of power fluctuation monitoring system using IOT.

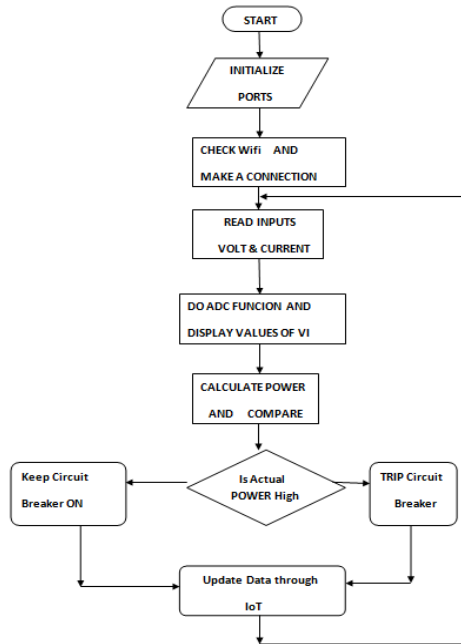

Fig.5. Flowchart of Power Fluctuation Monitoring System

IV. RESULT AND DISCUSSION

The Power fluctuation monitoring is done using IOT are fed into the Arduino uno which indicates it to the Electricity Board. From Electricity Board server, the information about the bill amount and exceed the load demand to the consumer through IOT. Depending on the power consumption, when the consumers load exceeds the set value, the Auxillary load is controlled automatically. The power consumption and billing information is continuously transmitted by the use of Internet of Things and monitored by the Electricity Board server.

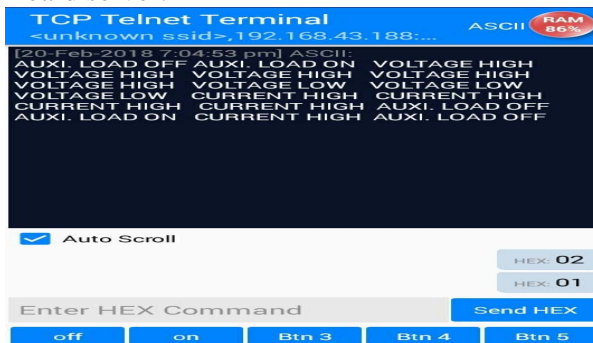

Fig. 6 IOT Result



Fig. 7 Output from LCD display

ADVANTAGES OF THE PROPOSED SYSTEM:

- The users can be aware of their electricity consumption.
- The human work of collecting readings by visiting every home at the end of every month can be avoided by generating Electricity bills automatically.
- Load demand excitation is monitored using IOT and load is shut down by means of set value and Keys is used as an acknowledgement for on and off control.
- Due to shudding down of auxillary load, power theft is rectified.
- At maximum peak hours, excess load consumed by the consumers is reduced.

V CONCLUSION

In this paper, a power fluctuation monitoring system is a method which a CT, PT and Arduino uno applied to the power system fields. The proposed system has the characteristics of steadiness, reliability, fast data acquisition and inexpensiveness. All these advantages have made it the ideal system for power fluctuation monitoring.

REFERENCE

- [1] BirendrakumSahani,TejashreeRavi, Akibjaved Tamboli, Ranjeet Pisal (2017) "IOT based Smart energy meter" *International Research Journal of Engineering and Technology*, Vol: 04, Issue: 04P-ISSN: 2395-0072.
- [2] Zhenmei Li, Jin Shen, Peiyu Wei, Tianze Li (2010) "Voltage Fluctuation and Flicker Monitoring System Using LabVIEW and Wavelet Transform" *JOURNAL OF COMPUTERS*, Vol. 5, NO. 3.
- [3] Wang Qiang, Ma Jianlin, Pang Zhaolong, Liu Yingjie(2013) "Design of A Power Quality Monitoring System Based on MSP430" *International Conference on*

*Computer Science and Electronics
Engineering ICCSEE*

- [4] K.Bowya, I.S.Pradeeba Levina and K.Aruna,(2017) “GSM Based Smart Energy Meter” *International Journal for Modern Trends in Science and Technology*, Vol. 03, Issue 04, , pp. 162-168.
- [5] K. Yingkayun and S. Premrudeepreechacharn, 2008, "A Power Quality Monitoring System for Real-Time Detection of Power Fluctuations" *IEEE TRANSACTIONS Power Symposium* , pp. 1 – 5.
- [6] Z. Kokolanski, M. Srbinovska, A. Simevski, C. Gavrovski and V. Dimcev (2009) "Power Quality Monitoring and Power Measurements by Using Virtual Instrumentation” *ELECTRONICS*, Vol 13, NO. 1.
- [7] Bharathi R. Madhushree M. E.Priyanka Kumari (2017) “Power Consumption Monitoring System using IOT” *International Journal of Computer Applications (0975 – 8887) Volume 173 – No.5*,