



SIMULATION OF POWER FACTOR CORRECTION FOR THE SINGLE PHASE AND THREE PHASE LOAD BY CAPACITORS

Dhruvang R Gayakwad

Asst. Professor, G.I.D.C. Degree Engg. College, Navsari

Abstract

Most of the industries facing the problem of Government Penalties and High power consumption due to the low power factor. For low power factor industry will be penalize by government. Industrial unit charges are higher than Domestic charges .Hence Electrical bill increases which affects the profit and losses of Industry. With the help of capacitors power factor is maintained near to unity. To understand this phenomenon any R-L load is taken. Measuring the reactive power consumption of that particular load capacitor is selected to supply that much amount of reactive power and it will be switched on as per the loading take place. Results can be easily analysed by the waveform of current, reactive power and power factor.

I. INTRODUCTION

Most of the industries are facing the problem related to high power consumption due to low power factor. The industries will be penalizing by government for keeping the power factor low. Now, industrial per unit power charges are higher than domestic charges. Hence, industrial electrical power bill directly affect the profit and loss of it. So it is very necessary to keep the power factor within its maximum suitable value i.e. one (unity).

As the industries having maximum inductive load like induction motors, transformers, incandescent lamps, florescent lamps, induction heating, induction furnace, arc welding machines etc. These loads will directly affect the power factor and decrease it. So, there will be the

problems related to the improper operations of machines and more power consumption due to low power factor. Based on that Automatic Power Factor Correction (APFC) Panel are used to reduce the penalties applied by the government for low power factor.

Hence, Automatic Power Factor Correction method is one of the best method to increase the power factor. In this method the current and voltage phase difference is measured and according to the measured value the capacitor will supplies the reactive power and increase the power factor very nearer to its unity value, When the inductive load increases the capacitors will get turn on automatically and maintain power factor to the unity value. The current and voltage phase difference is measured and according to the measured value the capacitor will supplies the reactive power and increase the power factor very nearer to its unity value.

In industries; there may be the problem of poor power factor and less efficiency because the induction motors are widely used for different production work. Hence, such poor power factors are main reason for poor efficiency of the motor and it decrease the age of machines. Also the industries will be penalized for the low power factor. So, it is very necessary to find out the solution of these problems.

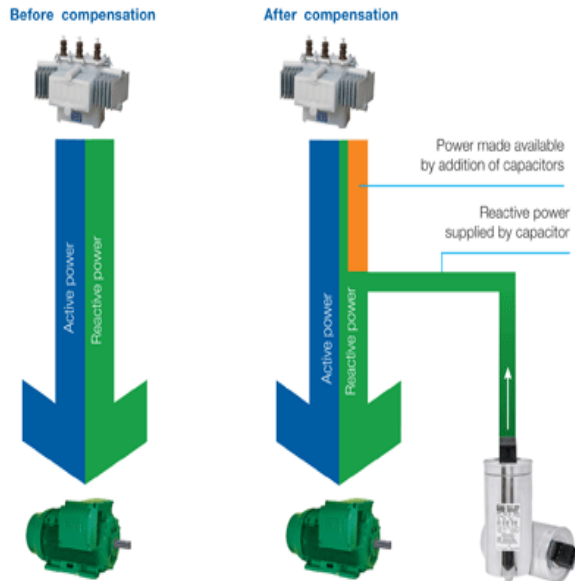

Inductance and capacitance react 180 degrees to each other. Capacitors stores KVARs and oppose the reactive energy caused by the inductor. The presence of both a capacitor and inductor in the same circuit results in the continuous alternating transfer of energy between the two. Thus, when the circuit is balanced all the energy released by the inductor is absorbed by the capacitor.

It is not necessary to draw it from the generators in the transmission grid, but a capacitor near the motor terminals can also supply it.

By the automatic power factor controller we will solved out the problem of lagging power factor and correct the power factor with the help of shunt capacitors automatically. And also capacitors decreases the magnitude of reactive power (KVAR), thus the power factor will be increased.

Calculations:

$$\cos\phi = P/S$$

$$Q = V^2/X_c$$

$$X_c = 1/(2\pi f c)$$

$$C = Q/(2\pi f V^2)$$

For this we need to measure all the above parameters.

Then we can find power factor

To correct that low power factor to unity we need to put capacitor of above calculated value in parallel with the load. Now we can see the unity power factor as a result.

II. SINGLE PHASE WITHOUT CAPACITOR(C=0 F)

Here R= 10 ohm & L= 100mh is taken as a load. All the parameter are measured.

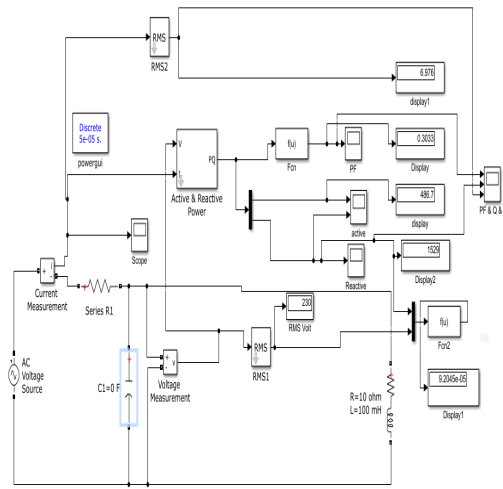

P=486.7 w
Q= 1529 VAR
P.F.= 0.3033
I=6.976 A

CAPACITOR VALUE NEEDED TO CORRECT THE POWER FACTOR IS C= 9.2045E-05 F

III. AFTER INSERTING CAPACITOR OF CALCULATED VALUE

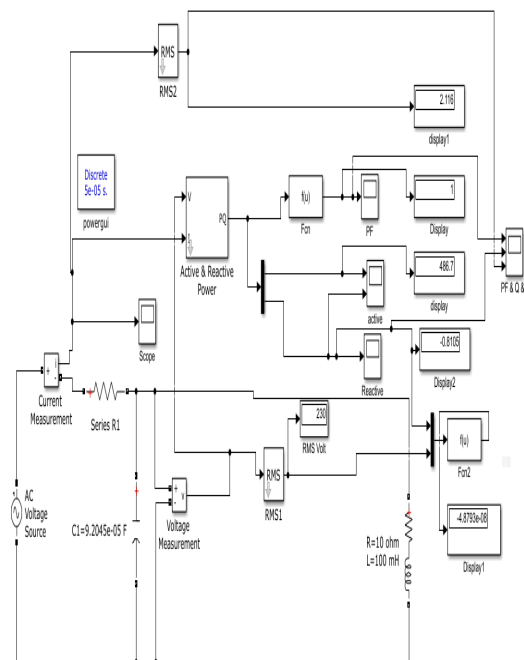

P=486.7 w
Q= -0.8105 Var

P.F.= 1

I=2.116 A

We can see that reactive power is almost zero and due to that P.F. =1

Current is also reduced from 6.976 to 2.116 A.

Active power is unaffected.

IV. TWO DIFFERENT LOADING CONDITION & THEIR RESPECTIVE CAPACITORS

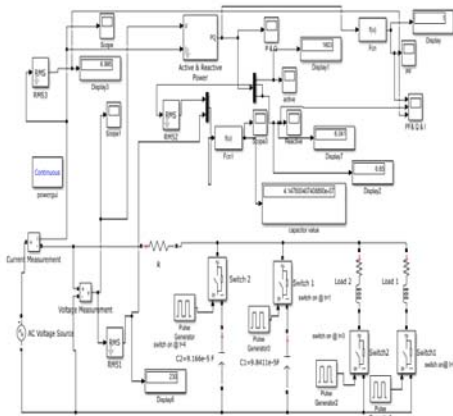

Load 1 (R=15 ohm & L=70mH) is on at t=0 and Load 2 (R=10 ohm & L=100mH) is on at t=3 seconds

So according to both loading conditions two capacitors are installed & they are turned on & off @ t=1 & t=4 seconds respectively. We can see the results in power factor & reactive power from the graph. In this way anyone can switch capacitor on & off with respect to loading condition.

V. WAVEFORM OF POWER FACTOR, REACTIVE POWER & CURRENT

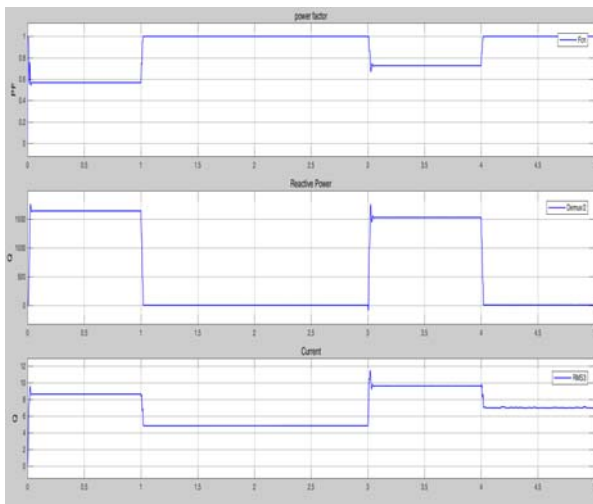

When load 1 is on @ t=0 seconds

P.F.=0.5664

P=1123 w

Q=1634 var

I=8.624 A

Capacitor value needed to correct the power factor is C1= 9.8411e-5 F

This C1 is on @ t=1 seconds, so again Reactive power, Current & P.F. changes

Q=3.187 var

I=4.835 A

P.F.=1

Similarly when load 2 is on @ t= 3 seconds, capacitor C1 is already connected and load 1 is also on at this instant.

P.F.=0.7255

P=1604 w

Q=1522 var

I=9.608 A

Capacitor value needed to correct the power factor is C2= 9.166e-5 F

This C2 is on at t= 4 seconds, so again Reactive power, Current & P.F. changes

P.F.=1

Q=6.041 var

I=6.995 A

This all values can be observed from the graph. We can conclude that by switching capacitor on we can improve P.F., reduce current as well as reactive demand also.

VI. THREE PHASE LOAD WITHOUT CAPACITOR

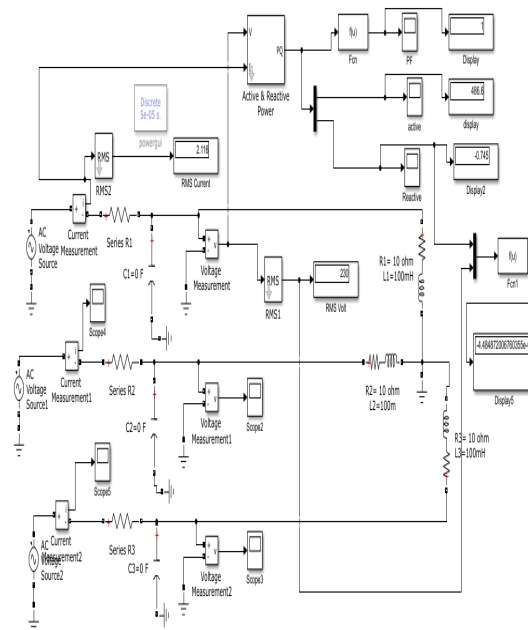

Here we have measured all the parameters of a three-phase balanced R-L load.

Each phase contains $R=10\text{ ohm}$ & $L=100\text{mH}$.
 P.F.=0.3033
 $P=486.6\text{ w}$
 $Q=1529\text{ var}$
 $I=6.976\text{ A}$

Above parameter are measured for each phase
 For star connected Capacitor value needed to
 correct the power factor in each phase is
 $C=9.20416\text{e-}05\text{ F}$

VII. THREE PHASE LOAD WITH STAR CONNECTED CAPACITOR

P.F.=1
 $P=486.6\text{ w}$
 $Q=-0.7539\text{ var}$
 $I=2.116\text{ A}$

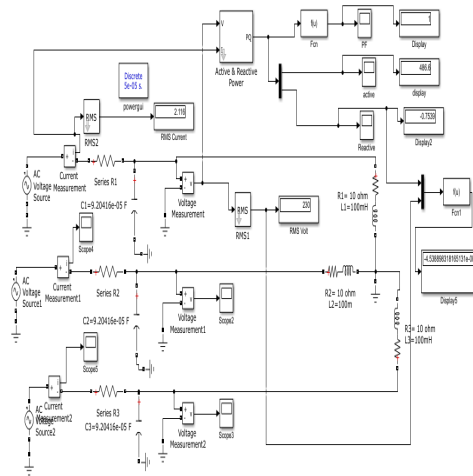

VIII. THREE PHASE LOAD WITH DELTA CONNECTED CAPACITOR

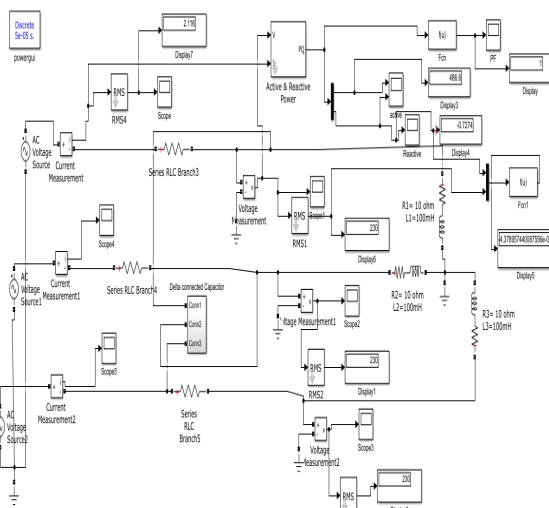

Value of load is remaining same but capacitors are connected now in delta instead of star.

So there is only change in value of capacitor which is one third of star connection. Means here value of each capacitor connected in delta $C=3.068\text{e-}5\text{ F}$
 After connection of this capacitor in delta again we get the same result of above three phase load.

IX. CONCLUSION

For any given loading condition either it is single phase or three phase power factor correction is possible with help of above simulations. This calculation is for separate loading condition.

REFERENCES

- [1] "Electrical Power systems" book by V. K. Mehta
- [2] MATLAB Help simulation software
- [3] Juan Dixon, Luis Morán, José Rodríguez, "Reactive Power Compensation Technologies", State-of-the-Art Review (invited Paper)
- [4] Taufik, Emili Schaefer, Makbul Anwari, Mohammad Taufik "Performance Analysis of Shunt Reactive Power Compensators", 2009 Third Asia International Conference on Modelling & Simulation.