



## SMART HELMET AND INTELLIGENT BIKE SYSTEM

Prajitha Prasad A<sup>1</sup>, Reshma Mohan<sup>2</sup>, S Lekshmi Raj<sup>3</sup>, Sreelekshmi S<sup>4</sup>, Divya R Pillai<sup>5</sup>

### Abstract

**The main objective of this paper is to build a safety system which is integrated with the smart helmet and intelligent bike to reduce the probability of two-wheeler accidents and drunk drive cases. The flex sensor checks if the person wearing the helmet or not. Alcohol sensors detect the alcoholic content in riders' breath. If the rider is not wearing the helmet or if there is any alcohol content found in rider's breath, the bike remains off. The bike will start until the rider wears the helmet and if there is no alcoholic content present. When the rider crashes, helmet hits the ground, sensors detect the motion and tilts of helmet and reports the occurrence of an accident. It sends information of the corresponding location to family members of the rider and emergency contact number**

**Index Terms: Biker's safety, Accident detection, Smart helmet, Alcohol detection.**

### I. INTRODUCTION

A traffic accident is defined as any vehicle accident occurring on public highway roads. The thought of developing this project comes to do some good things towards the society. Two wheeler accidents are increasing day by day and lead to loss of many lives. The main aim of our project is to build a safety system which is integrated with the smart helmet and intelligent bike to reduce the probability of two-wheeler accidents. If any accident occurs no persons at place where to give information to the ambulance or parents. This is a situation we observe our day to day life, a thought of finding some solution to resolve this problem come up with this idea of giving the information about accident as soon as possible and in time. Smart helmet focusing on three major applications which are helpful in our day to day life. At first and most one is the ignition of the bike will not on if we are not wearing the helmet. Secondly alcoholic driving is not possible by using this smart helmet. If the

rider is alcoholic, the bike will not start. Third application is accident detection. If person met with an accident, no one is there to help him and simply leaving or ignoring the person, In such situation informing to ambulance or family members through mobile to rescue him for an extent.

Various technologies are now available for bike rider safety. Wireless communication between bike to helmet and bike to traffic signal and speed breaker[1]. The system will be comprised of a helmet module including stereo speakers and microphone, and a bike mounted base unit. The system will make use of different wireless communication protocols including ZigBee and another radio frequency protocols. when the rider or driver driving a bike he don't know where the speed breakers are there. By using RF technology they will find out where the speed breakers are there. Smart Helmet with Sensors for Accident Prevention [2], the microcontroller used in the system is Peripheral Interface Controller (PIC). Force Sensing Resistance (FSR) and the speed sensor are used as sensors to operate this system. Signal transmission between the two circuits is using a radio frequency concept. 315 MHz Radio Frequency Module is used since the range between the circuits is short. Drawback of this work as the motorcycles engine will only start is the helmet is worn and the belt has been buckled. A Solar Powered Smart Helmet With Multifeatures[3].In this helmet have multi features like Engine control system with the smart, in built Bluetooth system ,accident alert system, emergency alert switch (it gives the emergency message to police or family members) and cell phone charging with the solar power. Accidental Avoidance and Cabin Safety System for Automobiles [4].This system endures mainly with two modules namely Gas sensing module and Obstacle detection module these are interfaced with ATmega16 microcontroller. IR sensors transmit signal from its sensor head and

again receive the signal reflected from an obstacle and instruct the microcontroller which alerts the driver with an alarm and controls the vehicle by stopping it. The gas sensor here is mounted inside the vehicle detects the level of the toxic gases it informs to the microcontroller which alerts the persons inside the vehicle with an alarm. Smart Helmet Using GSM and GPS Technology for Accident Detection and Reporting System [5], vibration sensors are placed in different places of helmet where the probability of hitting is more which are connected to microcontroller board. So when the rider crashes and the helmet hit the ground, these sensors sense and then controller extract GPS data using the and when the data exceeds minimum stress limit then GSM module automatically sends message to ambulance or family members. Smart Helmet by Kajal Thakare[6], systems which are already implemented are using various sensors such as FSR sensor, Alcohol sensor, Vibration sensor. In some cases for detecting the road accidents and locating the address GSM and GPS techniques are used. The bioelectric sensors for monitoring Brain, Cardiac and Respiratory Activity. Hence smart helmet is a special idea which makes motorcycle driving safer than before. Alcohol detection by AbhinavAnand[7], mainly to detect the alcohol drunken people. MQ-3 sensors are used here to detect the alcohol content in the breath and if the rider is alcoholic the bike will not start. Communication possible by using RF module. Intelligent accident identification and location display system[8] This system has been developed and implemented using the smart sensors and LPC2148 controller based mobile technology. If the accident occurred then this system immediately transmit the location of the accident and persons heart beat status to the emergency care centre phone number through SMS. Bike rider's safety using helmet [9]. The system design will be such that without wearing the helmet the rider cannot start two wheelers. The helmet will be connected to vehicle key ignition systems which will be electronically controlled. Smart Helmet For Indian Bike Riders [10], provides an excellent alternative to the existing accidental avoidance techniques. These include Hi-tech helmet and an electronic system which can be applied in mechanical system as two wheelers to avoid accidents on roads by compulsion of wearing helmet

## II. TECHNICAL STUDY

The technics here we used in our project are alcohol detection and accident prevention. The ignition of the bike starts only if we wore the helmet. For the above applications three sensors and GPS GSM interfacing also used.

### A. FLEX SENSOR

The Flex sensor is used to detect weather the helmet is worn or not. Here the flex sensor is connected with the Arduino in the helmet unit. It is a flex sensor which is 2.2 inches in length. This sensor works by bending the sensor itself. As the sensor is being flexed or bent, the resistance across the sensor increases. The greater the angle of bending, the greater the resistance. This can be tested with multimeter.

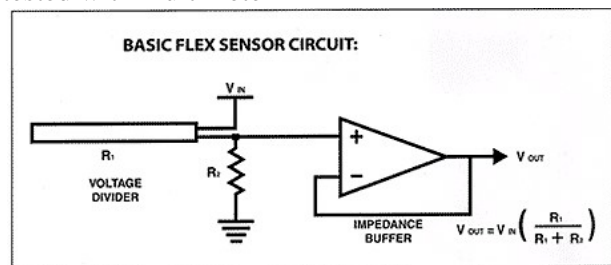

Fig-1: Basic flex sensor circuit

### B. MQ-3 SENSOR

The alcohol Sensor(MQ3) module is useful for gas leakage detection and it is also suitable for detecting Alcohol, Benzine, CH<sub>4</sub>, Hexane, LPG, CO. Due to its fast response time and high sensitivity, measurements can be taken as soon as possible. The sensitivity of the sensor can be adjusted by using the potentiometer. The MQ3 gas sensor is alcohol sensor which is used to detect the alcohol concentration in the breath. This sensor provides an analog resistive output based on alcohol concentration.

### C. Accelerometer ADXL335

The ADXL335 is a small, thin, low power, complete 3-axis accelerometer sensor with signal conditioned voltage outputs. The sensor can measure the static acceleration of gravity in tilt sensing applications, as well as dynamic acceleration resulting from motion, shock, or vibrations.

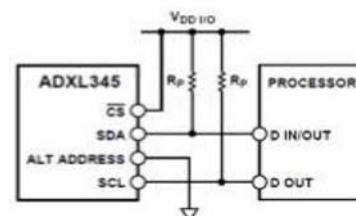

Fig-2:- Interfacing diagram of Accelerometer

The user selects the bandwidth of the accelerometer using the CX, CY, and CZ capacitors at the Xout, Yout, and Zout pins.

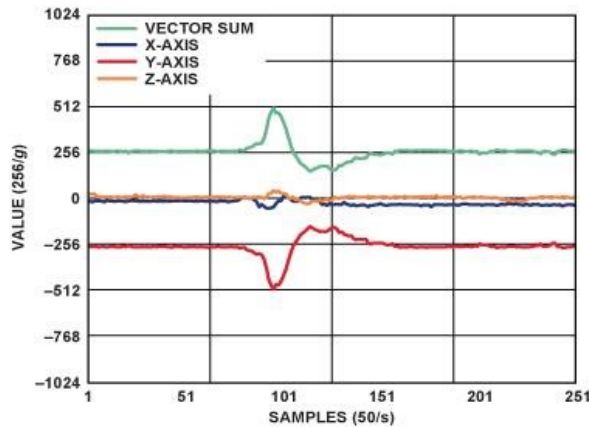

Fig-3: Tilt variations of three axes.

The three of these sensors in our helmet unit are controlled by ATmega328P microcontroller in the Arduino UNO. The board is equipped with sets of digital and analog input/output (I/O) pins that may be interfaced to various expansion boards and other circuits. The board features 14 Digital pins and 6 Analog. Arduino consists of both a physical programmable circuit board and a piece of software. Arduino IDE software is used here for programming data. We already mentioned that we designing of this system include two units the data transmission is done by using RF module. GSM modem is a class of wireless modem devices that are used here to transmit the accidental information to the predefined number. It requires a SIM card just like mobile phones to activate communication with the network. Also they have IMEI number similar to mobile phones for their identification. In Smart helmet the GPS module is used to locate the accident location and then the latitude and longitude dimension messaged to the concerned number. The receiver section is bike unit, it consist of RF receiver, relay and a power supply unit. The ignition on/off condition check by using relay. The input section has a coil which generates magnetic field when a small voltage from an electronic circuit is applied to it. This voltage is called the operating voltage. The output section consists of contactors which connect or disconnect mechanically.

**III. METHODOLOGY**

**A. BLOCK DIAGRAM**

Block diagram consist of two units Helmet unit and Bike unit. Helmet unit consist of Arduino Uno, Flex sensor, MQ-3 sensor, ADXL-335 Accelerometer, RF transmitter, Buzzer, GSM modem, GPS modem, LCD display, Power supply. Bike unit consist of RF receiver, Relay, Ignition system, Power supply unit. The whole system is controlled by arduino Uno unit. Different functions are controlled by using sensors. The arduino UNO is placed in the helmet unit. The inputs from different sensors are given to arduino unit and which is analysed by the arduino and given to the bike unit by RF transmission. The power supply is given to the bike unit.

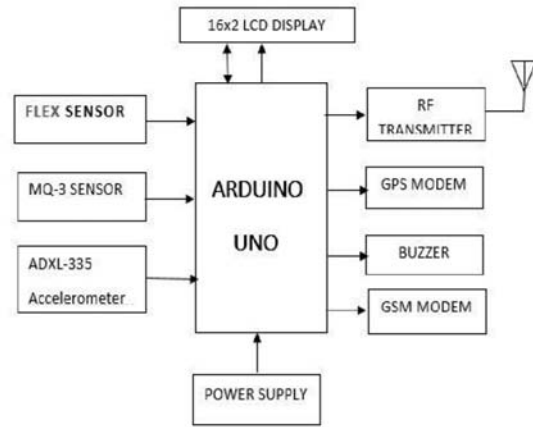

Fig-4:Helmet unit

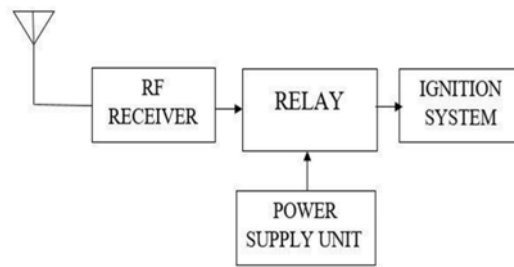

Fig-5:Bike unit

**B. CIRCUIT DIAGRAM**

The communication between the helmet and bike unit is done using RF module. The circuit contains encoder and decoder circuit. Encoder is on helmet side, which is used to convert parallel data into serial data. Decoder is on ignition side which is used to decode serial data. It converts the serial data into parallel data. The output of the flex sensor will be given to the RF transmitter

and the data will be transmitted. The digital pin of the MQ3 sensor is set as the test pin. The output of the MQ3 sensor is connected to the digital pin of the arduino. Pin two of the flex sensor is connected to the analog pin of the arduino. Pin two of the flex sensor is connected to the analog pin of the arduino. According to the output of accelerometer, information regarding the accident would be send to the GPS module. The receiver pin of the arduino is connected to the transmitter pin of GPS. The transmitter pin of the arduino is connected to the receiver pin of the GSM.LCD display is used for monitoring the output.

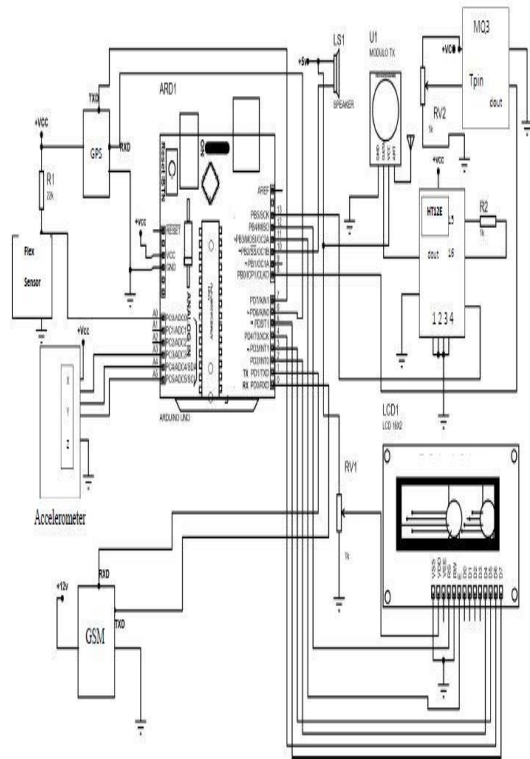

Fig-6: Transmitter unit

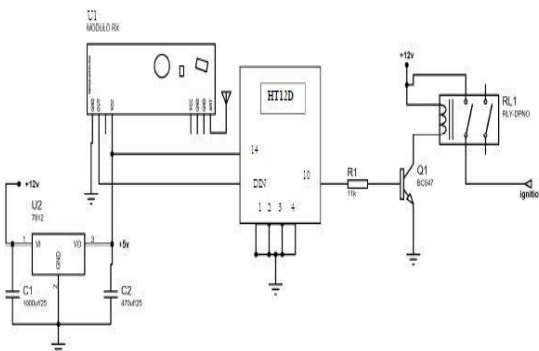

Fig-7: Receiver unit

The receiver circuit consists of a RF receiver module, relay and a power supply unit. The transmitted data from the helmet unit is received by the RF receiver and is decoded by the decoding circuit and it is given to the digital pin of arduino. The ignition would be switched on only when the rider is not drunk and if he wears the helmet.

#### IV. CONSTRUCTION

As we mentioned earlier the construction of our system consist of two units namely helmet unit and a bike unit. The flex sensor is placed on inside upper part of the helmet where actually head was touched with sensor surface and the sensor bends. Alcohol sensor is placed on in front of rider's mouth. It can sense easily sense the alcohol content in the breath. The battery and regular circuits was fixed inside the helmet. RF transmitter circuit was placed on inside the helmet, antenna are located outside the helmet. The tilt sensor is placed outside in the left or right position of the helmet. The bike unit is mounted on actual bike.

#### V. WORKING AND FLOW CHART

If the pin of MQ3 is low and that of flex sensor is high, two signals would be generated and the two data's from the arduino can be encoded and given to the RF transmitter. The engine of the two-wheeler is turned on using the relay. The relay is programmed to be turn on only when these two conditions are satisfied. The transmitted data from the helmet unit is received by the RF receiver and is decoded by the decoding circuit and it is given to the digital pin of arduino. The ignition would be switched on only when the rider is not drunk and if he wears the helmet. The information regarding the axis is given to the analog pin of arduino. According to the output of accelerometer, information regarding the accident would be send to the GPS module. The receiver pin of the arduino is connected to the transmitter pin of GPS. When the accelerometer is tilted and detected the threshold, the GSM is turned on and the message is send to the predefined number. The transmitter pin of the arduino is connected to the receiver pin of the GSM.LCD display is used for monitoring the output. All the outputs are displayed on the LCD

screen and its images are also included in the result section.

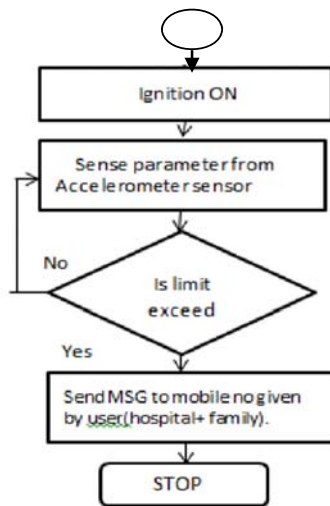
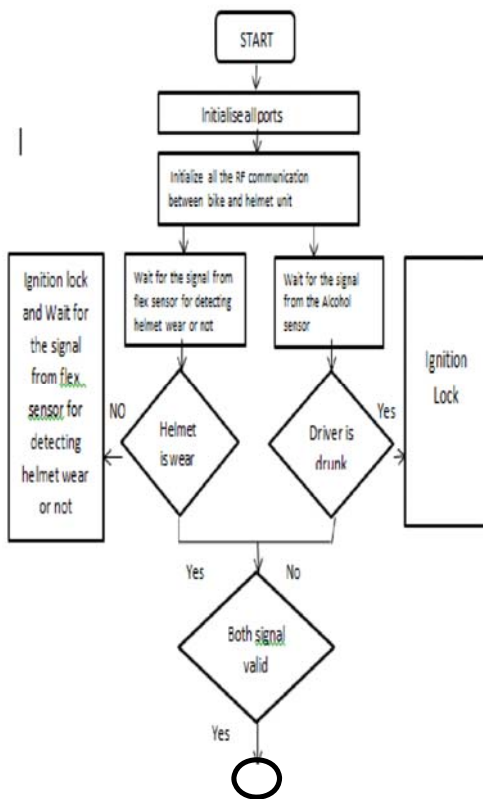

Fig-8:Flow chart

### VI. CONCLUSION

The two-wheeler safety system developed with smart helmet and intelligent bike system is reliable and aims to help in the prevention, detection and reporting of accidents hence reducing the probability of

the drunk drive cases. It also has several advantages compared to the previous systems. Our proposed system gives the primary importance of preventing the accidents and ensures safety for a greater extent in two wheelers. Nowadays, most accident cases occur due to motor bike. The severities of those accidents are increased because of the absence of helmet or by the usage of alcoholic drinks. By implementing this system, a safe two wheeler journey is possible which would decrease the head injuries throughout accidents caused due to the absence of helmet and additionally reduce the accident rate due to drunken driving. A GSM modem is used in this system that will send a message to the predefined numbers that are programmed using microcontroller in case of any accident.

### VII. ADVANTAGES

Accidents can be detected in accident prone zones easily and thus medical services can be provided easily. By using alcohol detector, drunken drive will be simply avoided, hence reduces the probability of accidents. It is economical and can avoid the fine imposed by making the helmet wearing is compulsory. Easy to implement. Cost effective and efficient. By the usage of various sensors, it is easily replaceable.

### VIII. FUTURE SCOPE

We can use solar panel for helmet power supply and this same panel power supply can be used for charging our mobile. In future we have a tendency to construct an intelligent system of compact size. Light dimmer sensors can be used to dim the light automatically when light from other vehicles fall on it. Government should enforce laws to install such system in each two wheelers. We can implement various bioelectric sensors on the helmet to measure various activities. We can use small camera for recording of the driver's activity. It can be used for passing message from one vehicle to another vehicle by using wireless transmitter. If in a case helmet gets stolen then bike can be started by the password.

## IX. RESULTS

When the flex sensor becomes flexible, change in resistance occurs and a constant voltage is produced. This voltage is connected to analog pin of arduino. When alcohol is detected, its digital output is connected to the digital input pin of arduino as shown in figure 10. Here we are using ADXL 335 as a tilt sensor. It has three axes. It is connected to a reset pin. This pin would be set in x-direction and it is according to the variation in tilt to the y and z direction that occurrence of accident is detected as shown in figure 11. GPS is connected to arduino digital pin and this arduino is connected to GSM and it is from this module that the message concerning the occurrence of accident is sent to a predefined number and corresponding location is also specified as shown in figure 12 and 13. An encoder IC is used in the transmitter section. Its function is to encode all the sensor's output and this signal is transmitted by the RF unit except GSM and GPS module. The receiver section consists of relay, ignition, power supply and a decoder IC. The transmitted signals are received by using RF receiver and these signals are decoded using HT12D decoder IC. This decoded output is connected to ignition. An npn transistor is given to the ignition to provide voltage to the base and the emitter is grounded. This base voltage makes the transistor on. Relay which is used acts as a switch and it makes the ignition on as shown in figure 9.



Fig-9:Ignition on



Fig-10:Alcohol detected



Fig-11:Accident detected



Fig-12:Message sent

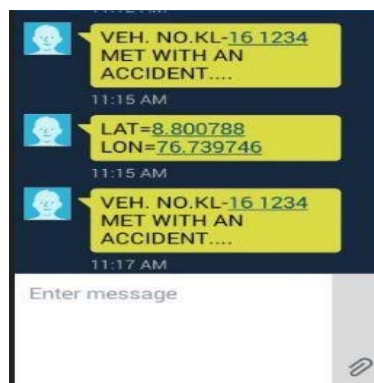

Fig-13:Location detected

## REFERENCES

- [1] An Optimal Driving System by Using Wireless Helmet by K. Rambabu<sup>1</sup>, B.Premalatha and C. Veeranjanyulu
- [2] Smart Helmet with Sensors for Accident Prevention Mohd Khairul Afiq Mohd Rasli, Nina Korlina Madzhi, Juliana Johari Faculty of Electrical Engineering University Technology MARA40450 Shah Alam Selangor MALAYSIA julia893@salam.uitm.edu.my.
- [3] Solar Powered Smart Helmet With Multi features Mr.P.Dileep

- Kumar<sup>1</sup>,Dr.G.N.Kodanda Ramaiah<sup>2</sup>  
Mr.A.Subramanyam<sup>3</sup>, Mrs.M.Dharani<sup>4</sup>  
International Journal of Engineering  
Inventions ISSN: 2278-7461, p-ISSN: 2319-  
6491 Volume 4, Issue 10 [June 2015] PP: 06-  
11)
- [4] Harish Chandra Mohanta, Rajat Kumar Mahapatra and Jyotirmayee Muduli(2014), Anti-Theft Mechanism System with Accidental Avoidance and Cabin Safety System for Automobiles, International Refereed Journal of Engineering and Science (IRJES), Vol. 3, No. 4, pp. 56-62.
- [5] Manjesh N, Prof. Sudarshan Raj, Smart Helmet Using GSM and GPS Technology for Accident Detection and Reporting System, International Journal of Electrical and Electronics Research, Vol. 2, October - December 2014
- [6] Smart Helmet by Kajal Thakare, September 2014.
- [7] Abhinav Anand Alcohole detection, Department of Electronics and Telecommunication, IJEETC, Vol. 4, April 2015
- [8] G. Vara Prasad Reddy, Intelligent accident identification and location display system using ARM, Department of the Electronics and Communication Engineering, IOSR Journal of Electronics and Communication Engineering, Vol. 9 Aug-2014
- [9] Manasi Penta, BIKE RIDERS SAFETY USING HELMET, Department of Electronics and Telecommunication, IJEETC, Vol. 4, April 2015
- [10] Amitava Das, Priti Das, Soumitra Goswami, Smart Helmet For Indian Bike Riders, Eleventh IRF International Conference, ISBN: 978-93- 84209-47-6, 17th August 2014, Chennai, India.