



MAKING OLED PANELS MORE ENERGY EFFICIENT –REVIEW

Shaik Kareemulla¹, Harsh Srivastava²

^{1,2}MVJCE, Bangalore

Abstract

Energy utilization of cell phones has moved toward becoming a vital thought because of the confinement of battery limit, and OLED panels are the most energy consuming part of cell phones. The key thought is to dispose of undesired subtle elements while protecting the locale of the picture by boosting the color and spatial information. So in this paper, we study about different approaches to save energy of OLED panels and the energy saved by these procedures and some future approaches to save energy of OLED panels.

Index Terms: DVS; Edge detection algorithm; NON-ROI dimming; OLED; ROI abstraction.

I. INTRODUCTION

Since the evolution of Smartphones in recent years till date we have around 2 billion users. Since smartphones are fueled by batteries and batteries are restricted in size and capacity, which suggest that low energy utilization is an earnest worry for cell phones. Current cell phones are outfitted with a wide scope of I/O parts and sensors, for example CPU, Wi-Fi NIC, GPS, and Audio. Among them OLED is the most eager for power part, which consumes around 38-45% of total battery. LCD panels that require high backlight illumination the new developing OLED panels bring another open door for energy sparing since they illuminate on their own based on power supplied to each pixel.

There are various procedures proposed which reduce the consumption from different aspects and in this paper we are going to study briefly about different approaches to make OLED an energy efficient panel. Like Dynamic Voltage Scaling (DVS), Fine grained DVS, ROI abstraction and dimming techniques and some future upcoming energy saving plans for OLED

energy saving.

Dong et al had proposed for the first time the power modeling and optimization for OLED displays and he observed that OLED power consumption pattern was completely different from LCD because they had emissive nature.

Dynamic Voltage scaling was proposed by Shin which showcased by controlling the power supplied to each pixel based on OLED luminance the power could be saved. Consequently, power is saved on OLED display panel with some negligible alter in color and luminance of image.

In our second survey, we have considered fine-grained dynamic voltage scaling to reduce the power consumption of OLED panels. The OLED panel is basically partitioned into small display sections where the supply voltage is adjusted based on the luminance of the image part displayed on that section. This technique proposes that even after scaling down the voltage the quality of color accuracy is maintained and MSSIM is maintained around 0.95.

In the third paper they propose a technique to make image consume less energy they make use of two techniques namely ROI abstraction and NON-ROI dimming, which can significantly reduce the energy consumption while maintaining the image quality. Using this approach we can save around 22.5% which shows the effectiveness and efficiency of this approach.

II. RELATED WORKS

A. What is OLED?

OLED stands for "Organic Light Emitting Diode" "it is an emerging technology for displays in various devices. The Main principle behind OLED technology is electroluminescence it offers brighter, thinner,

high contrast, and flexible displays.

B. Structure of an OLED.

Substrate (clear plastic, glass) - The substrate underpins the OLED.

Organic layers - These layers are made of natural atoms or polymers.

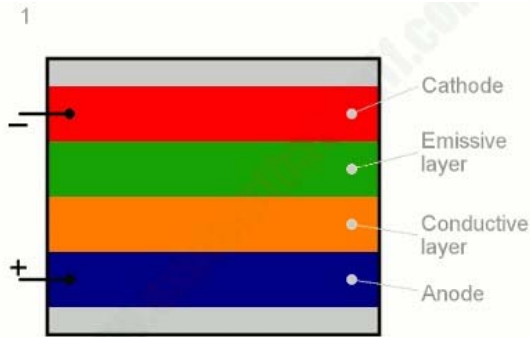

Emissive layer - This layer is made of characteristic plastic particles (distinct ones from the leading layer) that move electrons from the cathode this is where light is delivered. One polymer used as a piece of the emissive layer is polyfluorene.

Anode - The electrons are removed from anode or holes are added when is applied to the device.

Conducting layer - It is made of organic molecules such as polyaniline to transport "holes" from the anode.

Cathode - When current flows through device electrons are injected to it.

C. Power Model of OLED.

Organic light-discharging diode(OLED) is another rising display innovation which gives more extensive viewing angles and preferable power efficiency over conventional LCDs, and it is generally utilized as a part of business applications for example, display panels for cell phones and convenient computerized media players. The principle distinction between an OLED panel and a LCD is that an OLED panel does not require external lighting since its pixels are emissive. Each pixel of an OLED is comprised of three shading elements, specifically red, green and Blue. Dong et al first proposed control displaying and improvement for OLED panels, they demonstrated the power contributed by a solitary pixel, determined in (R, G, B), as equation (1).

$$P_{pixel}(R, G, B) = f(R) + h(G) + k(B) \quad ..(1)$$

$$P = C + \sum_{i=1}^n \{f(R_i) + h(G_i) + k(B_i)\} \quad ..(2)$$

$f(R)$, $h(G)$, and $k(B)$ Are power consumption of different pixel in devices respectively, and for n pixels the power consumption is given by equation (2). c Is the static energy consumption which is calculated when the screen is completely off. Figure1 shows the energy consumption of three colors with varying intensity on an μ OLED AMOLED display.

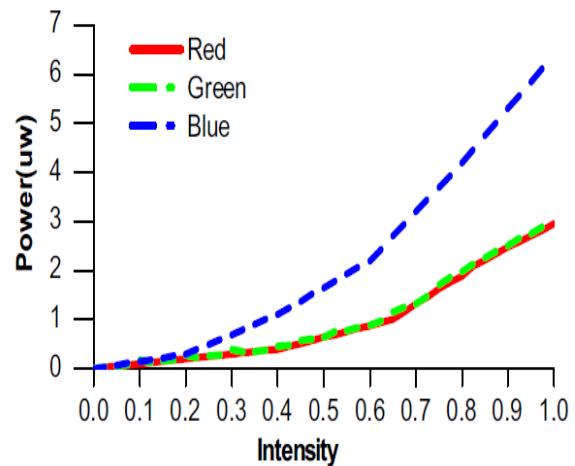

Figure: A: It shows Blue is most power hungry component at high intensity

D. Energy reduction

Due to the advancements in smartphones technologies, nowadays numerous services are offered owing to which power consumption has drastically increased. To overcome this concern many groundbreaking pieces of research are being undertaken to reduce the energy consumption of smartphones especially for OLED panels. In this paper, we basically study various techniques for energy saving, like dynamic voltage scaling, fine-grained dynamic voltage, context-aware dimming scaling, color remapping, ROI abstraction and NON-ROI abstraction.

E. Dynamic Voltage Scaling

This paper proposes the first OLED power saving procedure which preserves the color and luminance values of the displayed image. This technique is based on dynamic (driving) voltage scaling of OLED displays. This technique is similar to backlight scaling of LCDs. Using this method we can save the wasted power by using amplitude modulation driver. Experimental results show that the proposed technique with

image compensation can save up to 52.5% of the OLED power while maintaining the same image quality for the Lena image.

F. Fine-grained Dynamic Voltage Scaling

In recent years the size of smartphones displays has increased drastically, so as to display more content and secondly to increase the sharpness and other features of image. In this research, they propose a fine-grained dynamic voltage scaling (FDVS) technique to make OLED panel more energy efficient. An OLED panel is divided in to multiple sections whose supply voltages are separately adjusted based on the content displayed. Compared to existing work their techniques contributions towards energy saving are respectively:

- They propose that their technique is more efficient on power consumption at a cost of smaller granularity of display area.
- They propose a driver design which is DVS friendly OLED driver design which can effectively maintain the color accuracy when the supply voltage is scaled.
- They also calculate the coast of color remapping to improve the OLED panel under controlled supply voltage.

G. ROI Abstraction and NON-ROI dimming

The region of interest in an image is also referred as a salient region. It is a method of obtaining the important region while eliminating the undesired content of the image. To obtain such complexes we use canny edge detection algorithm. It is basically used for grayscale images and the algorithm is further modified to use it for RGB image.

Adjustment of luminance and saturation level of an image is a key technique to save energy, so as to have smooth transition in luminance and saturation in NON-ROI of image they adjust these values accordingly so as to have high quality image and also maintain average structure stability.

III. METHODOLOGY

3.1 OLED Dynamic Voltage Scaling (DVS)

3.1.1 Supply Voltage Scaling of OLED Drivers

The concept of DVS in OLED panels is basically to bring down the power loss due to V_{drop} by scaling down V_{DD} . As seen there is no

change in I_{cell} in the AM driver as long as driving transistor be in saturation mode. The driving transistor goes into triode region if I_{cell} is large enough. By decreasing V_{DD} we can bring down cell luminance but the distortion is introduced into the image. Scaling V_{DD} directly effect on I_{cell} . So we consider to restore luminance of image, to achieve this we use “image compensation” technique to restore the luminance along with the use of PWM driver. But, this technique cannot always restore the luminance of the image. Suppose if I_{cell} is maximum is large, even then maximum possible duty cycle is set to 100 %. Thus luminance distortion for very bright pixels become unavoidable for both AM and PWM drivers.

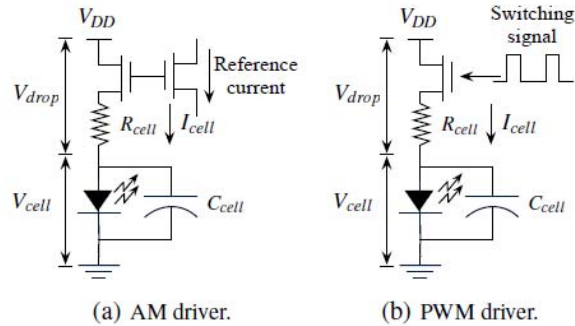

Figure 1: behavioural concept of (a) AM driver and (b) PWM driver for OLED displays.

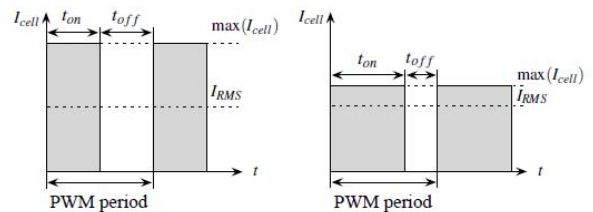

Figure 2: OLED cell current with (a) the maximum supply voltage and (b) scaled supply voltage.

Figure 2: OLED cell current with (a) the maximum supply voltage and (b) scaled supply voltage.

To save a significant amount of energy we allow a certain amount of color distortion in the image. $P_{loss} = I_{cell}V_{drop}$, this formula accounts for the loss in an OLED cell. The OLED has 50% to more than 100% headroom between V_{DD} and V_{cell} . The greater the headroom the better is the image quality but it also leads to large V_{drop} which leads

to power inefficiency. Similarly PWM drivers also maintain a large headroom to maintain high image quality and to guarantee accurate current control. This technique can be applied to both PMOLED and AMOLED panels where the storage capacitor is connected to GND. V_f And R_{cell} determine the maximum values of I_{cell} .

$$\max(I_{cell}) = (V_{DD} - V_f) / R_{cell} \quad (1)$$

The luminance of OLED is proportional to RMS value of I_{cell} , which is given as,

$$I_{RMS} = \max(I_{cell}) \sqrt{\frac{t_{on}}{t_{on} + t_{off}}} \quad (2)$$

Where t_{on} and t_{off} are the switch turn on and off durations in a PWM period. The loss in power during PWM period is given as,

$$P_{Loss} = I_{RMS}^2 R_{cell} \quad (3)$$

Analysis of OLED DVS with AM driver is simpler. I_{cell} Does not change overtime unless color is changed. The power loss is given as

$$P_{Loss} = I_{cell}(V_{DD} - V_f) \quad (4)$$

From the above two equations we can reduce power loss in an OLED cell while saving the luminance by using a reduced V_{DD} .

3.1.1 OLED Display Characterization

Here we measure the relationship between the power consumption and luminance of an OLED panel while changing and pixel colors. As shown in figure 3 we setup a measurement environment. The OLED used for analysis is UG-2076GDEAF02 with 2.2” inch PMOLED screen with PWM driver. We use a Konica Minolta CS-200 color meter to calculate luminance and chromaticity of OLED panel. This measurement is carried out in a dark room

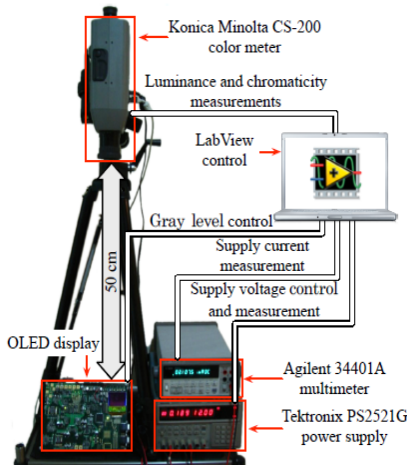

Figure 3: Experimental setup for OLED panel characterization.

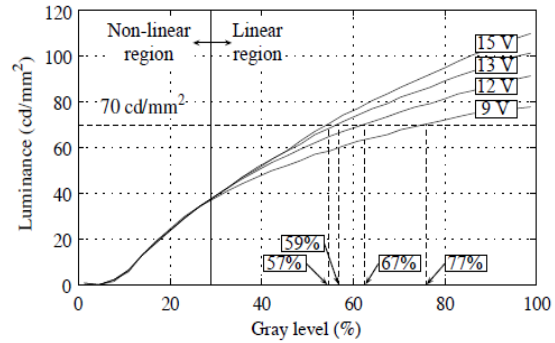

Figure 4: Measured luminance by V_{DD} and gray level.

We can take a part of characterization data for iterative purpose. This tells that OLED panels can achieve same luminance by adjusting the color value (gray level here) even by varying different V_{DD} , which proves the premise of DVS and OLEDs. As we can see in Figure 4, the OLED panel generates a 70 cd/mm² luminance with a 15 V, a 13 V, a 11 V, and a 9 V V_{DD} by setting the gray level to 57%, 59%, 64%, and 77%, respectively. It turns out that the luminance is not affected by V_{DD} when the grey level is below a certain level such as non-linear region in Figure 4.

Therefore, only in the linear region of Figure 4, we can compensate the voltage scaling-induced luminance reduction by modifying image data. We will perform the image compensation in next only for the linear region.

From (1) and (2), I_{cell} is directly proportional to V_{DD} and PWM duty cycle such that

$$d = \frac{t_{on}}{t_{on} + t_{off}}, \text{ i.e.}$$

$$I_{cell}(d, V_{DD}) = p_1 V_{DD} + p_2 d + p_3 \quad (5)$$

where p_1 , p_2 , and p_3 are characteristic coefficients. With the help of actual measurements, we characterize I_{cell} for an OLED panel in the form of (5).

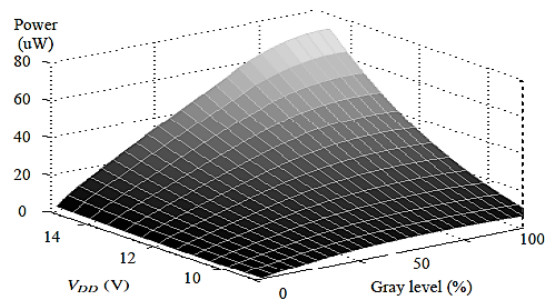

Figure 5: Measured power consumption by V_{DD} and gray level

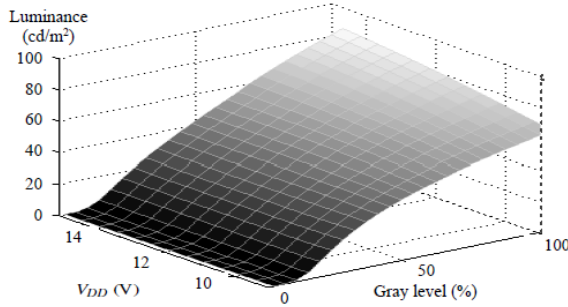

Figure 6: Measured luminance by VDD and gray level.

Figures 5 and 6 demonstrate the target OLED panel power consumption and luminance according to the gray level of pixels and the supply voltage. We set the same gray level to all pixels in the panel.

3.1.2 Color Characterization for OLED DVS

Here they use human perception-aware color space to evaluate image distortion. Typical RGB and CMYK spaces reflect the output of physical devices rather than human visual perception. CIE Lab color space is designed to approximate human-perceived vision. It is derived from the CIE 1931 XYZ color space, which reflects the spectral distribution of colors, and can be computed via simple formulas from the XYZ space. Due to its perceptual uniformity, its L component closely matches the human perception of brightness. The Euclidean distance in the Lab color space is widely used as a metric to measure the human perceived color difference. The XYZ measurement result showcase that X, Y, and Z values of RGB pixels are highly linearly proportional with the cell current or almost static regardless of the cell current. They build a transformation function using regression analysis which is given as

$$\begin{bmatrix} X \\ Y \\ Z \end{bmatrix} = \begin{bmatrix} aX \\ aY \\ aZ \end{bmatrix} = I_{cell} + \begin{bmatrix} bX \\ bY \\ bZ \end{bmatrix} \quad (6)$$

Here aX , aY , aZ , bX , bY and bZ are obtained by regression analysis on experiment results.

Algorithm 1: Algorithm for OLED DVS.

Input: Image $I = (R, G, B)$ and image distortion tolerance t_{image} .

Output: Transformed image I'

STEPS:

- 1 Set the supply voltage at the maximum supply voltage V_{max} .
- 2 Decrease a supply voltage step ΔV_{DD} from the previous supply voltage.
- 3 Calculate the power reduction by (5).
- 4 Calculate the average image distortion $\bar{\varepsilon}$ caused by supply voltage scaling.
- 5 Calculate minimum grayscale step increment for R, G, and B by (5)–(8) to increase enough amount of I_{cell} to satisfy the image distortion tolerance constraint ($\bar{\varepsilon} < t_{image}$).
- 6 Calculate the power of the modified image and scaled voltage by (5).
- 7 If the voltage scaling induced power reduction is less or equal to the required power to satisfy the image distortion tolerance constraint, then stop the DVS.
- 8 Otherwise, repeat 2–7.

3.2 IMAGE COMPENSATION

3.2.1 OLED Panels with an AM Driver

The transistor in AM driver is originally made to operate in the saturation mode. Operation in the saturation mode ensures the same I_{cell} regardless of changes in the V_{DD} level. The proposed OLED DVS lowers V_{DD} in such a way that the transistor is no longer supposed to operate in the saturation mode. More closely, if the color value is little enough, the reduced V_{DD} does not change the transistor's working mode. On the contrary, if the color value is large, reduced V_{DD} can change the transistor's operation mode into triode mode, which indicates that the original cell luminance is not preserved. In this paper, with AM driver, they do not attempt to combat the color distortion by changing the cell luminance. Instead they limit the number of distorted pixels by imposing a lower bound on the minimum value of V_{DD} .

3.2.2 OLED Panels with A PWM Driver

From (1), the reduced V_{DD} decreases the luminance of every OLED cell. At the same time, we can restore the luminance by increasing the PWM duty ratio, t_{on} in (2). As described in Section 3.1.2, bright images have pixels with a high grey level that are affected by V_{DD} decrease, and so image compensation is required. In contrast, dark images are not affected as much as the bright images by V_{DD} decrease, and so image compensation is seldom required for dark images. We convert an original

image $I=(R;G;B)$ in RGB space image to an XYZ space image such that

$I_{xyz}=(X,Y,Z)$ By (5) and (6). We again transform I_{xyz} into Lab color space image such that $I_{lab}=(L^*,a^*,b^*)$

by using the following transform functions :

$$\begin{aligned} L^* &= 116.(Y/Y_w)^{\frac{1}{2}} - 16 \\ a^* &= 500.((X/X_w)^{\frac{1}{2}} - (Y/Y_w)^{\frac{1}{2}}) \\ b^* &= 200.((Y/Y_w)^{\frac{1}{2}} - (Z/Z_w)^{\frac{1}{2}}), \end{aligned} \quad (7)$$

Where L^*, a^*, b^* are the matrices representing brightness, blue-yellow content, and re-green content in the Lab color space respectively.

3.2 Fine Grained Dynamic Voltage Scaling on OLED Display

1) Fine-grained Dynamic Voltage Scaling (FDVS)

The power consumption of a single color OLED cell equals $P_{OLED} = I_{cell} * (V_{dd})$. For a color adjustable OLED pixel with three color OLED cells, the total power consumption $P_{pixel} = P_{cell}(R) + P_{cell}(G) + P_{cell}(B)$. Here these parameters are the power consumption of red, green and blue OLED cells respectively. Here we see that the variety of efficiency of OLED cells for different color have been taken in consideration in their experiments.

2) V_{DD} Selection and Image quality

An OLED panel is divided into multiple display areas in FDVS technique, in which the V_{dd} is controlled independently. An object in an image is defined as a group of pixels with the similar RGB distribution. We note that human visual system is much more sensitive to major objects in discrete areas. To achieve the maximum power saving while maintaining the high quality of image, we select the V_{dd} 's of each pixel area which is made of RGB components of the parts of major object(s) in the area. For the display areas that do not include the major object(s), an extensive scaling is applied to obtain the maximum power efficiency with less degradation in image structural similarity.

When V_{dd} is limited, the colors of pixels with high luminance are affected first. Hence we define a parameter called ‘‘sacrificed luminance ratio (S.R.)’’ to denote the ratio between the total

sacrificed luminance at the scaled V_{dd} and the complete luminance of OLED display as:

$$S.R = \frac{\int_{GL_{threshold}}^{GL_{MAX}} (R_i + G_i + B_i) / \int_0^{GL_{MAX}} (R_i + G_i + B_i) \dots (8)$$

In this $GL_{threshold}$ is the minimum grey level above which the I_{cell} will shift to required magnitude at a scaled V_{dd} .

GL_{MAX} Is the maximum grey level in RGB space. The total loss in luminance is given as integration of the luminance of pixels in which at least one color OLED cell’s grey level is above $GL_{threshold}$. The total luminance is given as integration of luminance of all pixels in OLED panel. The scaling of V_{dd} incurs the decrease in $GL_{threshold}$ and increase in total sacrificed luminance.

S.R is used to guide the V_{dd} scaling in this FDVS technique. For example, we found that when S.R. =0.12, the corresponding V_{dd} can achieve a SSIM close to 0.98, which is the lower bound of a high-quality image.

3) Color remapping

The color distortion due to FDVS technique can be reduced by applying color remapping; the pixel’s color is adjusted to a brighter one by proportionally raising the grey levels of R, G, and B part to higher levels.

4) FDVS Flow

Step 1: OLED cell characterization. As shown in Fig. 8(a) and (b), the relationship between the $GL_{threshold}$'s of color OLED cells and the V_{dd} scaling is characterized as stored as lookup table:

Step 2: Image Dividing. The image is divided into multiple display areas based on the OLED panel size, resolution and the voltage regulator locations. The V_{dd} 's of each area are controlled separately.

Step 3: V_{dd} selection. A S.R. = 0.12 is applied to select the $GL_{threshold}$ and thereby, the V_{dd} of every display areas based on Eq. (8) and the OLED cell characterization table obtained in step 1.

Step 4: Color remapping. It is applied to improve the image quality if it cannot reach the requirement after step 3.

Step 5: Evaluation: Still If the image quality does not meet the expectations after step 4, we

increase V_{dd} 's and repeat Step 3 and 4. Otherwise, the flow ends.

Fig. 7 summarizes overall flow of FDVS technique.

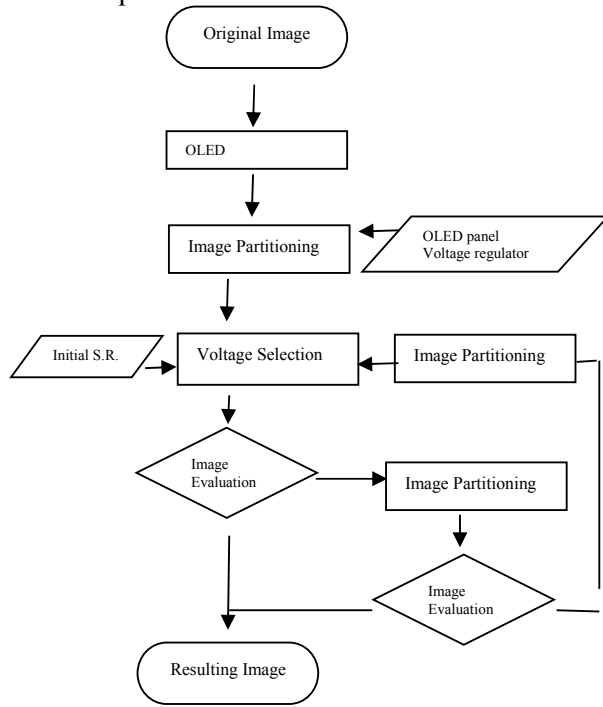

Figure 7: Overall flow of FDVS technique.

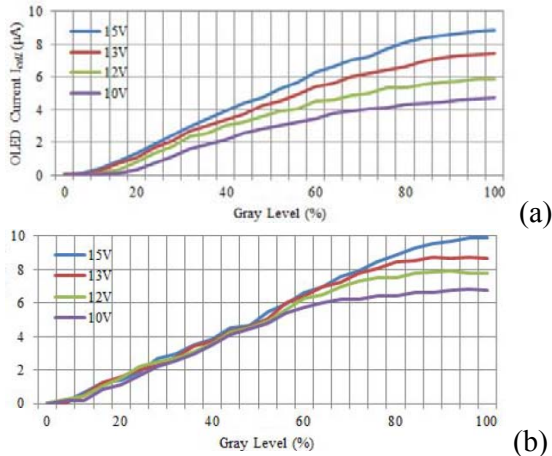

Figure 8: Relation between I_{cell} and V_{dd} of an AMOLED driver (a) conventional design. (b) DVS-friendly design.

3.3 ROI abstraction and NON-ROI dimming

3.3.1 Steps to obtain Region of interest using canny algorithm:

Step 1: Image Graying. First we change each RGB pixel in the color image to a gray value using:

$$P_{Gray} = P_R * 0.299 + P_G * 0.587 + P_B * 0.114 \quad (9)$$

Step 2: Smoothing is blurring of the image to remove noise. Canny algorithm uses the Gauss filter to smooth the image. In the subsequent application, we find that Gauss filter obviously blurred edge and the protective effect of high-frequency details is not obvious. In this paper we use Bilateral filter [20] for image smoothing, since which is an on-linear, edge-preserving and noise-reducing for images, which is based on the combination of the spatial proximity of the image and the similarity of the pixel value, considers the spatial information and the gray similarity. Moreover, it can also achieve the goal of edge-preserving while noise-reducing. The formula of bilateral filter is (4),

$$I^{filtered}(x) = \frac{1}{W_p} \sum_{x_i \in \Omega} I(x_i) f_r(\|I(x_i) - I(x)\|) g_s(\|x_i - x\|)$$

$$W_p = \sum_{x_i \in \Omega} f_r(\|I(x_i) - I(x)\|) g_s(\|x_i - x\|) \dots (9)$$

$I^{filtered}$ Is the filtered image, I is the original image, x are the coordinates of the current pixel to be filtered, Ω is the window centered in x.

Step 3: Non-maximum suppression. It can help to suppress all the gradient values to 0 except the local maximal, which indicates location whit the sharpest change in intensity value.

Step 4: Double Thresholding. After the previous process the edge pixels are quite similar to represent the real edge. But still there are some weak edge pixels present which are caused by noise and color variation. In order to overcome this situation it is important to filter out the edge pixel with the weak gradient value and preserve the edge with high gradient value. To obtain this we set a threshold value so that any pixel below that value will be discarded and vice-versa.

Step 5: Edge tracking by hysteresis. In this for weak edge pixels, there are still some questions on these pixels as which to be preserved or which to be removed. In order to get proper results it is assured that any pixel connected to strong edge pixel will be preserved and rest will be discarded. Then blob analysis is applied by looking at a weak edge pixel and its 8-connected neighbourhood pixels to track the edge connection.

3.3.2 NON-ROI Dimming

In this paper they use luminance adjustment and saturation adjustment both strategies simultaneously, reducing the maximum power consumption of NON-ROI area while ensuring the average structural similarity (MSSIM) of the image meet user's vision requirements.

IV. EXPERIMENT ANALYSIS

A. DVS Technique:

We evaluate the actual power gain and resultant image quality from the proposed

OLED DVS on real images. Figure 9 delivers important information about the original image and scaled image. It consists of i) image quality, ii) color histogram, iii) scaled V_{DD} , iv) power consumption, and v) power savings. We implement OLED DVS prototype and do the measurements on a real hardware testbed.

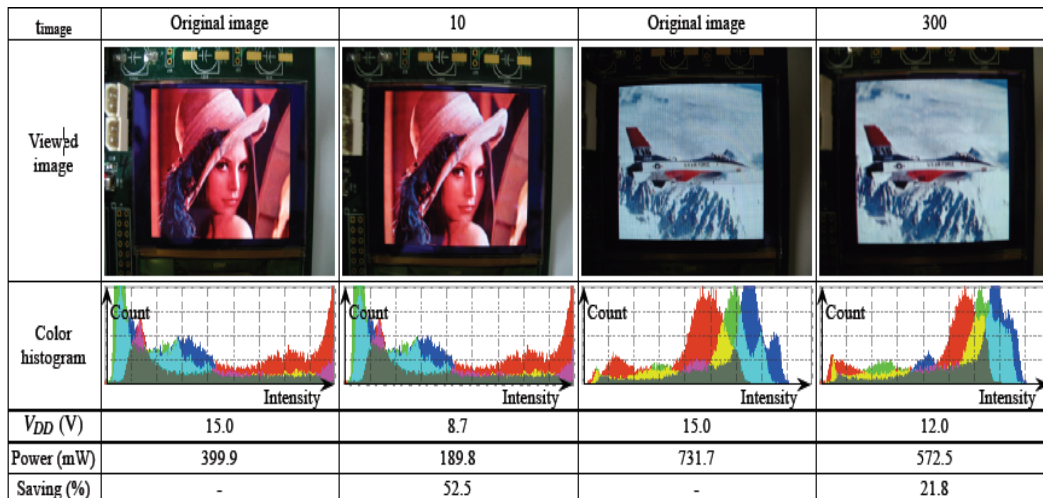

Figure 9: Image Compensation results, color histogram.

Here they work with two images, Lena and an airplane. The Lena image has a balanced color distribution while the airplane image has a severe skew toward the bright colors, which is very bad for the OLED DVS. The initial high luminance pixels are made to the maximum luminance as showcased in the compensated images and histograms. The saturated pixels result in the image distortion, but the overall image quality is not appreciably altered within the threshold value. The Lena image shows up to 52.5% power saving compared to the original image, where the 15 V supply is scaled down to 8.7 V and with almost zero color distortion. A sort of the worst case, the airplane, still exhibits 21.8% power saving compared to the original image with 15 V supply voltage for the threshold value of $t_{\text{image}} = 300$. Here they determine the distortion threshold by the most distorted pixel. In practice, pixels which are in very bright areas of the displayed image are damaged even after compensation. They determine the minimum value of distortion threshold so as to prevent the

most distorted pixel from losing more than half of their original luminance.

A. Fine Grained DVS Technique

1.) Impact of DVS-friendly OLED driver designs

As discussed, DVS friendly OLED driver can maintain the color accuracy as long as the required I_{cell} below the maximum driving strength of T_4 at the scaled V_{DD} .



Figure 10: image quality comparison of 'Lena' for different OLED driver designs. (a) Conventional driver (b) DVS friendly driver.

Fig. 10 shows the images on the OLED panels with conventional and DVS-friendly drivers, at a scaled voltage $V_{dd}=11.2V$.

Significant amount of quality degradation is observed in (10a) due to V_{dd} scaling induced. The SSIM of 10(a) is 0.8209, which is far below the “acceptable range” i.e. 0.94. As a comparison using this technique the SSIM is increased to 0.9863, which is a high quality image. Compared to the conventional OLED panel working at the normal V_{dd} of 15V, the power saving of Fig. 10(b) is 7.41%. To achieve a SSIM = 0.98 in the conventional OLED driver design, the V_{dd} must be increased to 14V, of which the power saving is only 20.66% (it is not shown in Fig. 10).

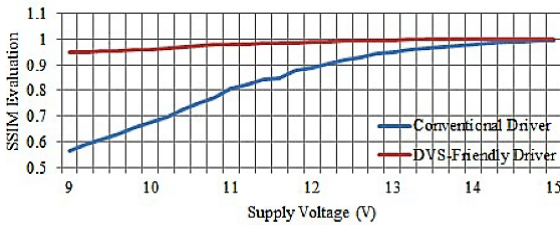

Figure 11: The required V_{dd} 's of two OLED driver designs at different SSIM indexes.

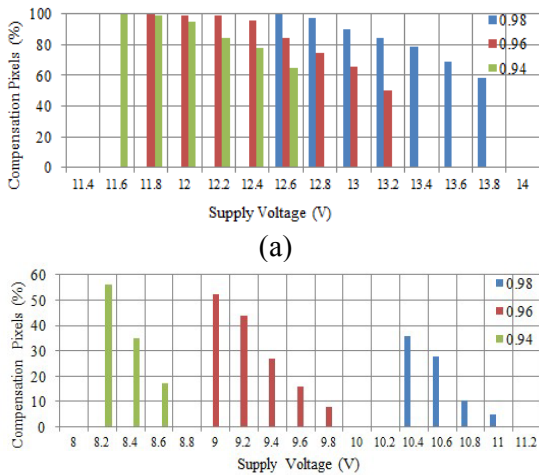

Figure 12: Color remapping costs of ‘Lena’ with (a) conventional drivers. (b) DVS-friendly drivers.

2.) Color Compensation (Remapping)

We also evaluated the cost of color remapping technique to improve the image quality of both conventional and DVS-friendly OLED driver designs. The cost is measured by the ratio between the numbers of the pixels to which the color remapping is applied and the total pixels. Fig. 12 shows the color remapping cost of ‘Lena’ with two OLED driver design at different V_{dd} 's

for SSIM= 0.98,0.96 and 0.94, respectively. V_{dd} Is safely reduced to 11.2V in DVS-friendly driver designs for a SSIM of 0.98 without any color remapping while $V_{dd}=14V$ is required in conventional driver designs.

9	10.2	10.8	10.2
10.2	10	10.6	10.4
11	10.2	10.4	9.6
11.2	9.4	11.6	11.8

V_{dd} Map (V)



Power Saving = 39.24%

(a)

12.2	12	12.2	12.4
12.4	12.4	12.6	12.6
12.2	10.8	11.8	12.6
12.4	12	12.2	12.6

V_{dd} Map (V)



Power Saving = 28.44%

(b)

Figure 13: Power saving evaluation of FDVS in different images

3.) Effectiveness of FDVS

FDVS allows V_{dd} adjustment at a smaller granularity and improves the power consumption of OLED panel and image quality.

As shown in Fig. 13 (a), the OLED power saving of ‘Lena’ is raised by 43.1% (from 27.41% to 39.24%), compared to the global DVS scheme with DVS-friendly driver designs. In ‘F16’, the power saving is raised by 25.9% (from 22.57% to 28.44%). The lower absolute power saving is because the major color occupies most of area in ‘F16’. Small V_{dd} adjustment places are left to each display areas, as shown in V_{dd} map of Fig. 12(b).

B. ROI Abstraction and NON-ROI dimming

First they get the energy consumption model in their experiments, which is composed of three functions $f(R), h(G), k(B)$. Since these function are for OLED display hence they measure it on an OLED-32028-P1 AMOLED display. Then they calculate the energy consumption by tracking the electrical current values with the DC voltage set to 5V. in measuring each of the pixel functions ,they change the intensity for 0 to 1(max) for testing

each color channel. In each test, they fill the OLED with corresponding color for 60seconds to calculate the average energy consumption and detail results are shown in Figure A, from Figure A we know that the power consumption of each color component is a nonlinear.

In order to compare the experimental results, they present other two adjust methods: AL of adjusting the luminance of the whole image and AS of adjusting the saturation of the whole image, and their approach is ALS, which adjust the luminance and saturation of NON-ROI of the image synchronously.

Figure 3 illustrates the effects of the above three Methods in processing image *Seagull*, (a) is the original Image, (b) is adjusting luminance of the whole image, (c) is adjusting saturation of the image and (d) is the image using their approach(ASL). Fig 3 shows the experimental results of their method in terms of power consumption and image similarity with the other two methods. From Figure 3, we observe that the images processed by the three methods have lower power consumption than original image. The original energy consumption of the image is $2374.836\mu\text{w}$, when the SSIMOVERVALL is 0.95 for the image after using three methods; the luminance of image (b) is reduced by 18% and energy consumption is reduced by 25%; for image (c), the saturation of image is reduced by 19.5% and energy consumption is reduced by 21%; and for image (d), the luminance is reduced by 15% and saturation is reduced by 13%, energy consumption is reduced by 28%.

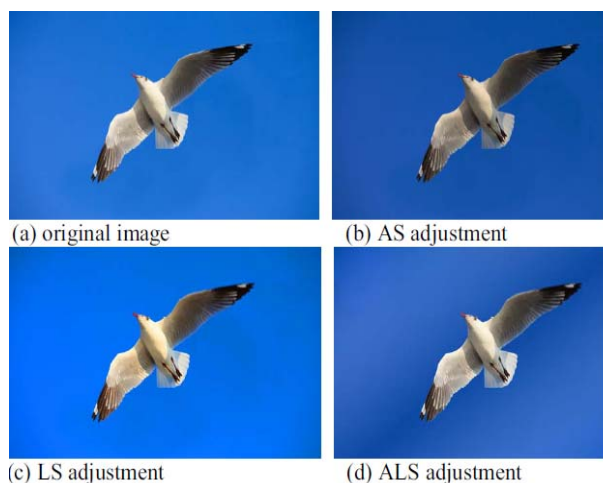

Figure 14: Images processed by the three methods

V. CONCLUSION

Here we give the final overview and future impacts of these three techniques:

A. DVS

This paper presented the first OLED power saving method that enables only minimal pixel distortion, small enough to work with natural images. Furthermore, the proposed technique can be applied to most OLED panel structures. They developed a unique power saving technique based on a careful analysis of the OLED driver architectures. The proposed method is called OLED dynamic voltage scaling (OLED DVS). The idea is to scale down the supply voltage and, in turn, reduce the wasted power caused by the voltage drop across the driver transistor as well as internal parasitic resistance. The proposed OLED DVS may incur image distortion after the supply voltage scaling. In this case, they compensate the image data based on the human-perceived color space. They demonstrated the OLED DVS with a prototype implementation and confirmed a 52.5% power saving for the Lena image with virtually zero distortion. As for future work, they will apply the proposed OLED DVS to AMOLED panels with amplitude modulation drivers. They will also complete the prototype implementation of a supply voltage control circuit and an image compensation method allowing OLED DVS and image compensation.

B. Fine Grained DVS

This paper proposes a fine-grained dynamic voltage scaling (FDVS) technique to reduce the power consumptions of OLED displays. By adopting the DVS-friendly OLED driver designs and local DVS control scheme, they made OLED panel power to reduce, while the incurred color distortions are minimized. Their experimental results on two real images show that compared to the existing global DVS solution, FDVS can achieve 25.9%~43.1% more power saving for the same image details with significantly reduced color remapping costs. Their future works will focus on the applications of FDVS technique in video streaming at low hardware and run-time costs.

C. ROI abstraction and NON-ROI dimming

Based on the experiments on the seagull image in figure (14) the comparison is shown in table (1)

Approach	Original	LS	AS	ALS
SSIM ROI	1	0.95	0.95	1
SSIM NON-ROI	1	0.95	0.95	0.9
SSIM OVERALL	1	0.95	0.95	0.95
Luminance	--	--	-0.21	-0.18
Saturation	--	-0.22	--	-0.13
Power/ μ	2374.83	1876.1	1781.1	1709.8
		1	2	8

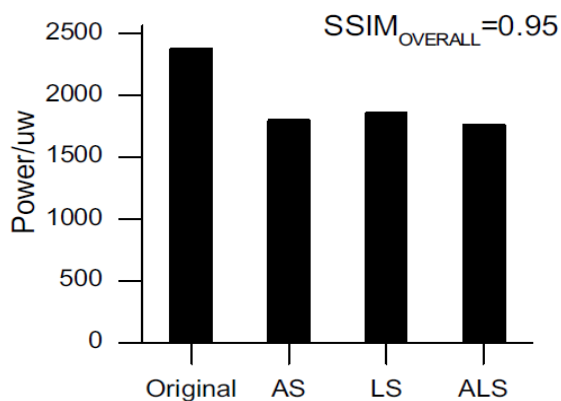

Figure 15: Energy consumption of different methods

In this work they propose a new method ALS for making image more energy efficient for OLED displays.

First they use edge detection algorithm to extract the ROI of an image, and then adjust the luminance and saturation of NON-ROI of the image gradually, by this way they reduce significant amounts of energy consumption while preserving high quality of the image. Experiment results show that when the MSSIM of the image keep at 0.95, their method can save 22% energy compared with original image, which is a simple and effective method for energy saving of smartphones. What's more, their method can be used for video and other multi-media applications.

VI. REFERENCES

[1] Chen X, Chen Y, Ma Z, et al. How is energy consumed in smartphone display applications?[C]//Proceedings of the

14th Workshop on Mobile Computing Systems and Applications. ACM, 2013: 3.

[2] Chen X, Zeng J, Chen Y, et al. Fine-grained dynamic voltage scaling on OLED display[C]//Design Automation Conference (ASP-DAC), 2012 17th Asia and South Pacific. IEEE, 2012: 807-812.

[3] Shin D, Kim Y, Chang N, et al. Dynamic voltage scaling of OLED displays[C]//Design Automation Conference (DAC), 2011 48TH ACM/EDAC/IEEE. IEEE, 2011: 53-58.

[4] N. Chang, I. Choi, and H. Shim, "DLS: Dynamic backlight Luminance scaling of liquid crystal display," IEEE TVLSI, vol. 3, no. 8, pp. 837-846, 2004.

[5] Deguang Li, Bing Guo, Junke Li, Yanhui Huang, Yan Shen. *Make Image More Energy Efficient for Mobile OLED Displays*[c]// 2016 13th International Conference on Embedded Software and Systems/